

INSTRUCTION MANUAL
ILLUMINANCE SPECTROMETER

IM-1000

IM-1000R

INTRODUCTION

Thank you so much for your purchasing our TOPCON TECHNOHOUSE Illuminance spectrometer IM-1000 / IM-1000R.



IM-1000 / IM-1000R is a handy type Illuminance spectrometer that can measure a wide range with high accuracy. This manual describes the outline, basic operation procedure, specifications and the communication specifications required for developing the software regarding the Illuminance spectrometer IM-1000 / IM-1000R. Read this manual carefully before putting the instrument into operation in a proper manner.

DISPLAY FOR SAFE USE

In order to encourage the safe use of products and prevent any danger to the operator and others or damage to existing facilities, important warnings are put on the products and inserted into the instruction manuals.







We suggest that everyone understand the meaning of the following displays and icons before reading the "SAFETY CAUTIONS" and text.

DISPLAYS









Display	Meaning
 DANGER	Ignoring or disregarding this display may result in serious injury or cause the death of human beings.
 WARNING	Ignoring or disregarding this display may result in serious injury or lead to life threatening situations.
 CAUTION	Ignoring or disregarding this display may lead to personal injury or damage of facilities.

- "Personal injury" means an injury, burn or electric shock which does not require entering or going to hospital.
- "Damage of facilities" refers to extensive damage to buildings, household belongings, livestock or pets.





ICONS

Icon	Meaning
	This icon indicates Caution. Specific content is expressed with words or an image located close to the icon. (Example  : Be careful for an electric shock.)
	This icon indicates Prohibition. Specific content is expressed with words or an image located close to the icon. (Example  : Don't touch the operating units.)
	This icon indicates Mandatory Action. Specific content is expressed with words or an image located close to the icon. (Example  : Install the grounding.)

WARNING

Icons	Prevention Item
 Prohibition	Don't use this instrument where combustible steam (for example gasoline) occurs. It may cause a fire.
 Prohibition	Don't disassemble or modify this instrument. A fire or electric shock may occur.
 Mandatory Action	Use the AC adapter which is an accessory sold separately. If not, the AC adapter malfunctions to cause a fire or electric shock.
 Prohibition	Don't disassemble the AC adapter. It may cause a fire or electric shock.
 Mandatory Action	Remove dust or water from the outlet of the AC adapter. If not, a fire may occur.
 Mandatory Action	If an abnormal noise, smell or smoke comes in this instrument, turn off the power and remove the AC adapter from the outlet at once. A fire will occur if using the instrument without repairing the troublepoint. Consult with your dealer or TOPCON TECHNOHOUSE.
 Mandatory Action	Operate battery under the guideline of the battery's manual. For your safety and correct battery operation, please carefully read the manual which come with a battery.
 Mandatory Action	Incorrect use of batteries may cause battery breakage, electrolyte leakage, heat generation, explosion etc.

CAUTION

Icons	Prevention Item
 Prohibition	Install the battery to be fit to the specified polarity. The leakage may cause an injury or malfunction.
 Prohibition	Don't put the instrument on an unstable place (e.g., on an unsteady table or a sloped surface). The instrument may fall off or turn over to cause an injury.
 Prohibition	Don't pull out or insert the plug by a moistened hand. It may cause an electric shock.
 Mandatory	Use only specified screws when using the tripod screw and screw holes for jig attachment. Do not tighten the screws any more than necessary. Doing so might cause internal breakage.

ESCAPE CLAUSE

- TOPCON TECHNOHOUSE shall not take any responsibility for damage due to fire, earthquake, actions by third persons and other accidents, or the negligence and misuse of the user and use under unusual conditions.
- TOPCON TECHNOHOUSE shall not take any responsibility for damage derived from the inability to use this equipment, such as a loss of business profit and suspension of business.
- TOPCON TECHNOHOUSE shall not take any responsibility for damage caused by operations other than those described in this Instruction Manual.
- TOPCON TECHNOHOUSE shall not take any responsibility for damage caused by operation failures due to combination with other devices.

CAUTIONS FOR USE

- Be sure to use the standard accessory, nickel hydride battery (charging type) for the instrument. If you use others except the standard accessory, the instrument may operate irregularly.
- The standard accessory battery, Nickel–metal hydride battery, may not be able to charge as normal at the first time of the use and after long term of non-use. In this case, you can improve the charging status of the battery by recharging several times.
If you find any unusual situations in battery or in the battery charger, stop using them and consult the operation manual and warranty card of the Nickel–metal hydride battery charger.
- Be sure to use the specified AC adapter for the instrument. Any other AC adapter will cause a malfunction. The input voltage is AC100 - AC240 and the power supply frequency is 50Hz - 60Hz.
- Be sure to turn off the power switch before connecting/disconnecting an external plug such as the AC adapter or RS-232C connector.
- When the instrument is not in use for a long time, disconnect the power plug to save the energy.
- Take out the battery to avoid leakage and store the instrument when it is expected to be disused for a month or more.
- The instrument does not have a waterproof structure. Don't use or store the instrument where it is splashed with water or other liquids.
- Don't measure a bright thing that is beyond the measuring range. The photo detector may be damaged to hinder the accurate measurement.
- Don't use the instrument in the place with much dust, high humidity or corrosive gas.
- Don't use the instrument where the temperature is sharply changed. The instrument has the built-in temperature compensation circuit. However, it cannot perform measurement precisely in the environment where the temperature is sharply changed.
- Don't use or store the instrument where a strong shock (e.g., falling off) or constant vibration is given. Because the instrument has the precise optical parts, a shock or vibration will cause a malfunction. When carrying the instrument, do not give a vibration or shock to it directly.
- Store the instrument under the normal temperature condition. Don't store it under the high temperature and humidity condition (e.g., in a vehicle).
- The instrument case is made of plastic. Don't wipe it, using any chemicals (acetone or thinner). Don't bring it near any place whose temperature is 50°C or more.
- Make a calibration regarding the instrument about once a year to keep the measurement accuracy. For the request of calibration, contact your dealer or TOPCON TECHNOHOUSE.
- The data stored in the built-in memory are erased in the calibration of the instrument. Make a backup file of the necessary data before requesting the calibration.

- Please do not peel off the sticker stuck on the back of the main unit. If you peel it off, all warranty will be invalid.

USER MAINTENANCE

Unless specified in this manual, the maintenance work shall be conducted only by a trained service engineer, to ensure the safety and performance of the instrument. The following maintenance work, however, may be executed by the operator. Regarding the maintenance method, read the applicable text in this manual.

■ Cleaning the instrument cover and detector window

If the instrument case and detector window are stained, moisten a soft cloth with the diluted neutral detergent and, with this cloth, remove the stain. Then, wipe the case and detector window with a dry, soft cloth.

The stain, fingerprint or oil on the detector window sometimes causes a measurement error. Carefully clean the detector window. **Don't use acetone, thinner, benzine or other solvents.**

CONTENTS





INTRODUCTION	3
DISPLAY FOR SAFE USE	4
1. PREPARATION BEFORE USE	13
1.1. CHECKING THE INSTRUMENT AND ACCESSORIES	13
1.2. NAMES AND FUNCTIONS OF COMPONENTS	14
1.2.1. Names and functions of switches on keyboard	16
1.2.2. Names and contents of data on the display screen	18
1.3. PREPARATION	19
1.3.1. Connecting the AC adapter	19
1.3.2. Installing the batteries	21
1.3.3. Installing personal computer	22
1.3.4. Turning ON/OFF the power	23
2. OPERATION OF THE MEASURED VALUE	24
2.1. DISPLAY OF THE MEASURED VALUE	24
3. SETTING OPERATION	25
3.1. FUNCTION MODE	25
3.1.1. Shifting to function mode/returning to measurement mode	25
3.1.2. Set item/Data display	26
3.2. DETAILS OF FUNCTION MODE	27
3.2.1. Setting the averaging count	27
3.2.2. Setting the interval mode	27
3.2.3. Setting the interval measurement conditions	28
3.2.4. Setting the manual measurement conditions	28
3.2.5. Setting continuous measurement	28
3.2.6. Setting the reference light source	29
3.2.7. Setting the sample light source	29
3.2.8. Setting the reference value	29
3.2.9. Setting the spectral correction	30
3.2.10. Setting the tristimulus values correction	30
3.2.11. Setting the wireless LAN	31
3.2.12. Setting the wireless LAN IP address	31
3.2.13. Setting the wireless LAN subnet mask	32
3.2.14. Setting the wireless LAN port number	32
3.2.15. Setting the wireless LAN access point	33
3.2.16. Setting the wireless LAN WEP	33
3.2.17. Setting the wireless LAN PASS PHRASE	34
3.2.18. Setting the RS-232C baud rate	34

3.2.19. Setting the back light.....	35
3.2.20. Setting the measurement data automatic saving function.....	35
3.2.21. Setting the measurement data history clearing function.....	35
4. COMMUNICATION WITH PERSONAL COMPUTER.....	36
4.1. COMMUNICATION COMMAND	36
4.2. COMMAND LIST	36
4.3. COMMUNICATION PROTOCOL	40
4.3.1. RM command.....	40
4.3.2. LM command.....	40
4.3.3. WHO command.....	40
4.3.4. VER command.....	41
4.3.5. SRL command.....	41
4.3.6. ST command	42
4.3.7. ST2 command.....	43
4.3.8. ST3 command.....	43
4.3.9. SP command	44
4.3.10. SP2 command	45
4.3.11. CST command.....	45
4.3.12. STP command.....	45
4.3.13. STR_# command.....	46
4.3.14. STR2_# command	47
4.3.15. STR3_# command	48
4.3.16. SPR_# command.....	49
4.3.17. SPR2_# command.....	50
4.3.18. MG_# command.....	51
3.3.19. MRW_# command	51
4.3.20. MRR command.....	51
4.3.21. MTW_## command.....	51
4.3.22. MTR command.....	52
4.3.23. FO_# command.....	52
4.3.24. FOR command	52
4.3.25. FW_##_#### command	52
4.3.26. FR_## command	53
4.3.27. TRW_# command.....	53
4.3.28. TRR command.....	53
4.3.29. XW, YW, ZW_##_#### command.....	53
4.3.30. XR, YR, ZR command.....	54
4.3.31. BRW_# command	54
4.3.32. BRR command	54
4.3.33. ACW_## command.....	54
4.3.34. ACR command.....	55
4.3.35. ERR command.....	55
4.4. MEASUREMENT DATA OUTPUT FORMAT	56

4.5. WIRELESS LAN CONNECTION	61
5. ERROR CODE	64
5.1. ERROR CODE LIST	64
APPENDICES	67
SPECIFICATIONS & PERFORMANCE	67
BLOCK DIAGRAM.....	70
EXTERNAL DIMENSIONS DIAGRAM.....	71
GRAPH	72
INFORMATION ABOUT OVERSEAS REGULATION.....	73

RULES OF SYMBOLS IN THIS MANUAL

This manual has the rules about symbols as shown below.

Symbol	Description
 “ ”	Shows the section to which you should make reference in this manual.
 < >	Shows other manuals to which you should make reference.
 NOTICE	Explains the points that you should understand and pay attention to.
 MEMO	Explains the knowledge that you should refer to or that will be useful.

1. PREPARATION BEFORE USE

1.1. CHECKING THE INSTRUMENT AND ACCESSORIES

Make sure that you have the instrument and accessories shown below.

If one of them is missing, contact your dealer or TOPCON TECHNOHOUSE.

- | | |
|--|---|
| ■ IM-1000 or IM-1000R instrument body | 1 |
| ■ CD-ROM
(Instruction manual/colorimetry program CS-900A) | 1 |
| ■ Hand strap | 1 |
| ■ Detector window cap | 1 |
| ■ RS-232C cable | 1 |
| ■ Nickel hydride battery charger set
(with four nickel hydride batteries) | 1 |

1.2. NAMES AND FUNCTIONS OF COMPONENTS

This chapter will explain the names and functions of the components with the illustrations about the instrument.

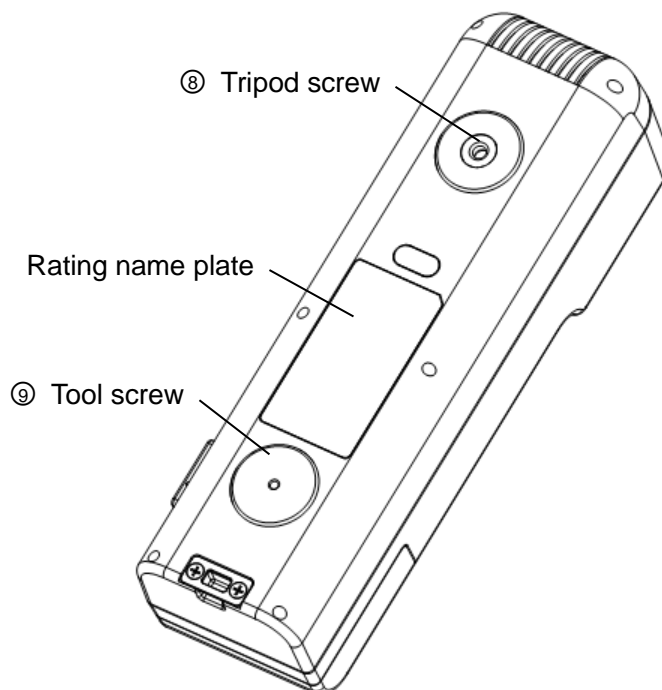
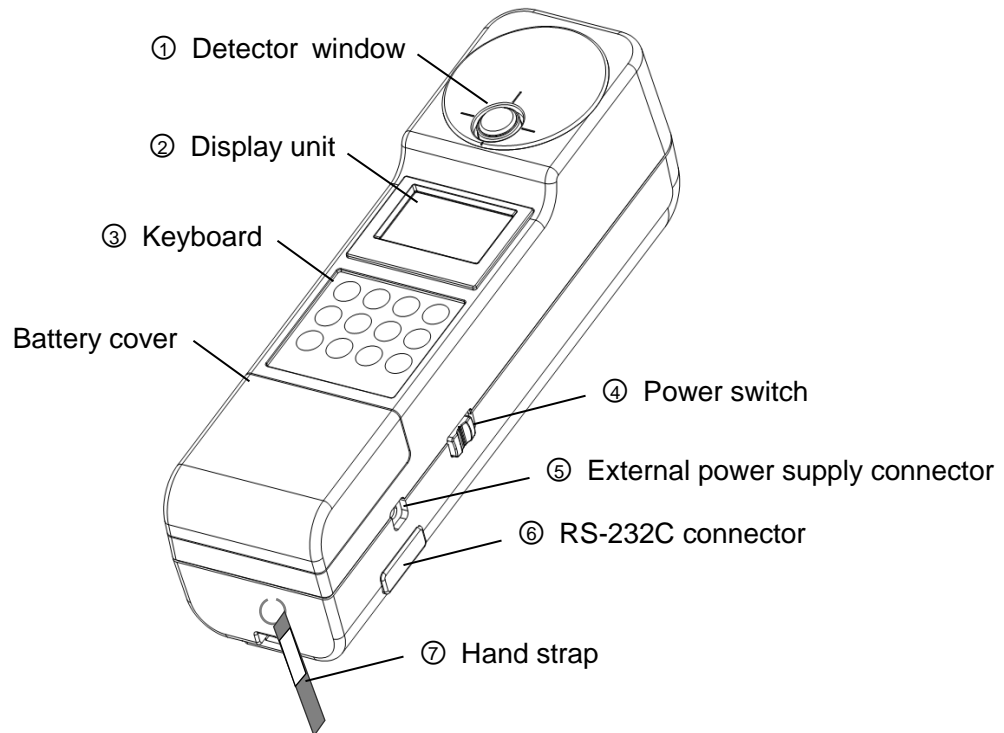



- ① Detector window.
Receives the light. Make the whole detector window receive the light to measure the illuminance.
- ② Display unit:
This is the liquid crystal display unit to indicate a variety of information such as the measured value or measurement condition.
- ③ Keyboard:
These switches are used to start/stop measurement, set the measurement conditions and perform other operations.
- ④ Power switch:
This switch is used to turn on/off the instrument.
- ⑤ External power supply connector:
Insert the output plug of the AC adapter (optional accessory) exclusively for the instrument into this connector.
- ⑥ RS-232C connector:
Connect the RS-232C cable (standard accessory) exclusively for the instrument to this connector.
- ⑦ Hand strap:
The falling-off prevention hand strap is attached here.
- ⑧ Tripod screw:
This screw is used to mount the instrument on the tripod.
TOPCON TECHNOHOUSE has adopted the screw for mounting the 1/4-20UNC (depth: 5mm) camera.
- ⑨ Tool screw:
This screw is used to mount the instrument on a system or others.
The size is "M3×0.5, depth: 6mm".

 Request	<p>Use only specified screws when using the tripod screw and screw holes for jig attachment. Do not tighten the screws any more than necessary. Doing so might cause internal breakage.</p>
---	---

1.2.1. Names and functions of switches on keyboard

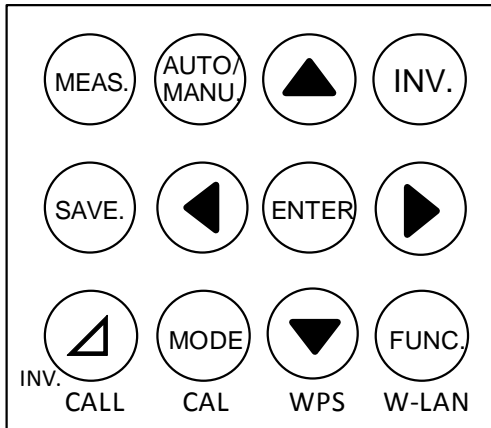
The names and functions of switches on the keyboard are mentioned below.



Name	Function
MEAS. switch	Starts/stops measurement. When continuous measurement is valid, measurement starts by pressing this switch once and stops by pressing it again. To stop measurement, sometimes the pressing time is longer than usual due to the integral time. When continuous measurement is invalid, measurement is performed once by pressing this switch once.
AUTO/MANU. switch	Select the measurement range mode. Each time you press this switch, the mode is changed. AUTO FULL (FL): At every measurement, the optimal measurement range and the integral time are set. AUTO FIRST (FS): Only at first measurement, the optimal measurement range and the integral time are set. The set range and time are kept until the measurement stops. AUTO ADJUST (AJ): When first measurement is done and when “over range” and “under range” are detected, the optimal measurement range and the integral time are set. MANUAL RANGE (ML): Measurement is done with the measurement range and integral time set for the “MANUAL” mode. MANUAL INTEG (MI): Measurement is done with the integral time set for the “MANUAL” mode. One of “FL”, “FS”, “AJ”, “ML” and “MI” is indicated on the display unit.
 switches	Used to display the items, the value increment/decrement, the digit shift and the measurement data history in the function mode.
INV. switch	Used to effectuate the [CALL], [CAL], [WPS] and [W-LAN] functions that are indicated at the bottom. When any of these functions is valid, “INV” is indicated on the display unit.

SAVE. switch	Saves the measurement data of the instrument (up to 50) in the internal memory. The saved data are not erased even if the power is OFF. When the measurement data history is saved, the startup time with "Power: ON" is delayed because the measurement data are read and internally calculated.
ENTER switch	This is used to decide the item, value, digit position, etc. in the function mode.
Δ switch	Measurement is done in the difference mode. The difference against the reference value is indicated as the measurement data.
MODE. switch	Select the display mode. Select one of [Ev/x/y], [Ev/u'/v'], [X/Y/Z], [Ev/Tcp/duv], [Ev/Ra/Tcp], [Ev/λd/Pe], [Spectral radiation graph] and [PPFD]. You can change "Tcp" of [Ev/Ra/Tcp] to "color rendering property evaluation" and "special color rendering property evaluation R1-R15" with [◀] and [▶] switches. In the color rendering property evaluation mode, the display update is slower than other modes due to the internal calculation time.
FUNC. switch	The system shifts to the function mode. In the function mode, set the measurement conditions, the communication conditions, the correction factor application, etc.
CALL switch (INV)	Indicates the reference value to be applied to the difference mode. To return to the normal mode, press [INV.] and then [CALL] again.
CAL switch (INV)	Unused.
WPS switch (INV)	You can set and connect the wireless LAN to the WPS device easily. For applying the WPS function, please read the instruction manual of the connected device together with this manual. (only IM-1000)
W-LAN switch (INV)	Connect the wireless LAN according to the setting conditions. To disconnect the wireless LAN, press [INV.] and then [W-LAN] again. (only IM-1000)

1.2.2. Names and contents of data on the display screen

The names and contents of data on the display screen are mentioned below.

① FL	② SGL	③ F	④ I	⑤ W	⑥ BAT	⑦ MEAS
⑧ r3					⑩ No.8	
⑨ Ev		100000 lx				
x		0.4474				
y		0.4076				

Name	Contents
① Measurement range mode	Indicates the measurement range mode which is currently set. FL/FS/AJ/ML/MI  "1.2.1. Names and functions of switches on keyboard"
② Average measurement	Indicates whether average measurement should be done. SGL : One measurement AVE : Average measurement
③ Correction	Indicates whether the correction factor should be applied. No indication : Correction factor is not applied. F : Correction factor of spectrum or tristimulus values is applied.
④ Interval measurement	Indicates whether interval measurement should be done. No indication : Normal measurement I : Interval measurement
⑤ Wireless LAN	Indicates the wireless LAN connection. (only IM-1000) No indication : Not connected. W : Connected.
⑥ Battery power	Indicates the remaining power of the driven batteries. No indication : Power is sufficient. BAT : Power is not sufficient. (Replace the batteries immediately.) Be sure to use the standard accessory, nickel hydride battery. If any other battery is used, the indication is sometimes different from the above.
⑦ Measurement status/INV	Indicates the measurement status and the [INV.] ON/OFF status. No indication: Measurement stops/INV is OFF. MEAS : Measurement is being performed. INV : INV is ON.
⑧ Measurement range	Indicates the measurement range. r1 - r4 : Range 1 to Range 4
⑨ Measurement data	Indicates the measurement data according to the display mode.  "1.2.1. Names and functions of switches on keyboard"
⑩ Measurement data history number	Indicates the measurement data history number. No. 1 - No. 50 (The number of the newest data is No. 1 and the sequential numbers are given.)

1.3. PREPARATION

This chapter will explain the preparation before starting measurement.

1.3.1. Connecting the AC adapter

How to connect the AC adapter to the instrument is mentioned below.



**Use the AC adapter which is an accessory sold separately.
If not, the AC adapter malfunctions to cause a fire or electric shock.**

WARNING



**Remove dust or water from the outlet of the AC adapter.
If not, a fire may occur.**

WARNING



**Don't pull out or insert the plug by a moistened hand.
It may cause an electric shock.**

CAUTION

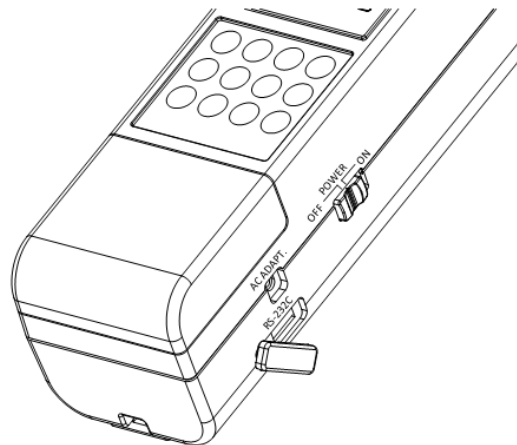

1. Make sure that the instrument is OFF.

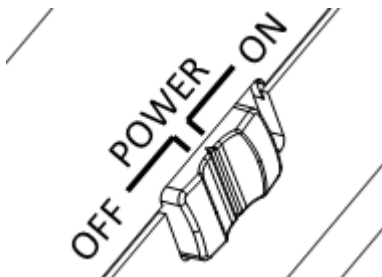

2. Insert the output connector of the AC adapter into the external power supply connector of the instrument.

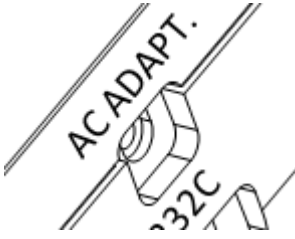

3. Insert the AC adapter plug into the outlet.

1.3.2. Installing the batteries

How to install the batteries is mentioned below.

Use the standard accessory, nickel hydride battery (charging type: 4 pieces).

 NOTICE	Use the standard accessory, nickel hydride battery (charging type). If you use others except the standard accessory, the instrument may operate irregularly.
--	--

MEMO

For charging the nickel hydride battery, refer to the instruction manual of the charger.

1. Make sure that the instrument is OFF.
2. Install the batteries according to the polarity indication in the battery chamber.
3. Attach the battery cover securely.

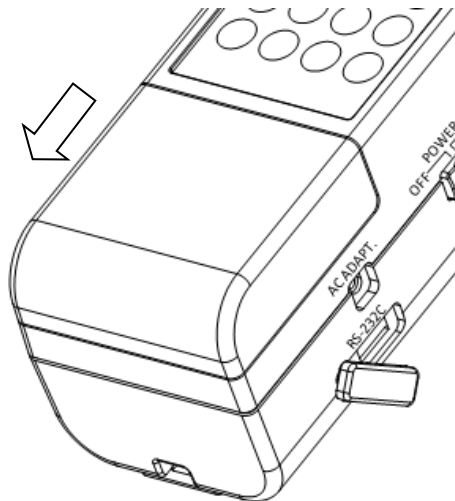

1.3.3. Installing personal computer

To connect a personal computer with the instrument, use the RS-232C cable exclusively for the instrument or the wireless LAN (IM-1000). The RS-232C signal line of the instrument is arranged according to the 9-pin D-SUB that is used in the DOS/V personal computer and others. When connecting with a personal computer through the extension cable, use the straight wiring cable.

 NOTICE	Don't connect and disconnect the connectors on condition that the instrument is ON.
--	---

MEMO

For the connection on the personal computer, refer to your computer's manual at the same time.

The RS-232C specifications are shown below. Others except the baud rate are fixed.

- Communication method : Full duplex
- Synchronization : Start-stop transmission
- Baud rate : 9600/19200/38400 bps (Bits Per second)
- Data length : 7 bits
- Parity : Odd number (ODD)
- Stop bit : 1 bit
- Communication type : Text (ASCII)
- Delimite : CR + LF (This is added to the last of a communication data line and then the data is sent.)

The wireless LAN specifications (IM-1000) are shown below. (Exclusively for Japan)

- Standard to be observed : IEEE802.11b infrastructure/ad hoc mode
- Frequency range : 2.4GHz band (1-13ch)
- Communication distance : Indoors 10m/Outdoors 15m typ
- Baud rate : 38400 bps
- Security : WEP/WPA/WPA2

MEMO

The communication distance and speed are changed due to the radio wave, obstacles, installation environment, etc. We cannot guarantee the communication speed and distance. Please understand this.

 NOTICE	<p>The frequency 2.4GHz band, which is used by the instrument, is also used by electronic ovens, medical instruments and other wireless stations.</p> <ol style="list-style-type: none">1. When using the instrument, check if any other wireless station or wireless equipment is used in its periphery.2. If radio wave interference has occurred, change the location of the instrument or stop using the wireless LAN for the instrument.3. The wireless LAN module, which conforms to the Japanese technical standards, is built in the instrument (IM-1000). Although inside of JAPAN ,and Europe (CE), North America (FCC), and South Korea (KC) which acquired wireless LAN certification can use wireless LAN function, wireless LAN cannot be used in another country and area.
--	---

4. If you use this equipment in the country which does not acquire the wireless LAN standard, be sure to turn off the wireless LAN function.

 "3.2.11. Setting the wireless LAN"

1.3.4. Turning ON/OFF the power

How to turn on/off the power is mentioned below.

- When turning on the power
Slide the power switch to "ON".

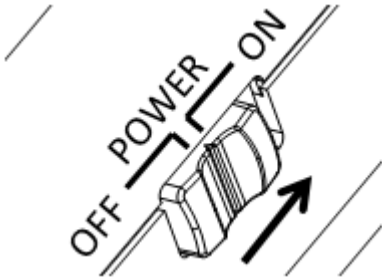

When the power is turned on, initialization starts. If an error occurs during the initialization, the error message is indicated on the display unit.

- When turning off the power
Slide the power switch to "OFF".

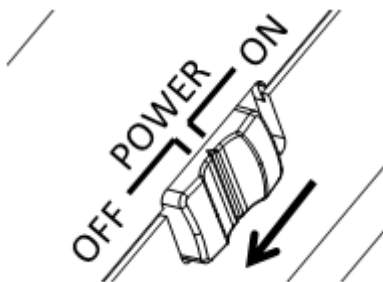

2. OPERATION OF THE MEASURED VALUE

2.1. DISPLAY OF THE MEASURED VALUE

You can change the measured value display mode by pressing the [MODE] switch when measurement stops. The changeable display modes are shown below.

Illuminance E_v /Chromaticity xy mode

E_v	100000 lx
x	0.4474
y	0.4076

Illuminance E_v /Chromaticity $u'v'$ mode

E_v	100000 lx
u'	0.4474
v'	0.4076

Tristimulus values XYZ mode

X	123.4
Y	234.5
Z	345.6

Illuminance E_v /Correlated color temperature T_{cp} /Deviation duv mode

E_v	100000 lx
T_{cp}	2856 K
duv	0.0012

Illuminance E_v /Average color rendering property evaluation R_a /Correlated color temperature mode

E_v	100000 lx
R_a	82
T_{cp}	2856 K

Illuminance E_v /Dominant wavelength λ_d /Excitation purity P_e mode

E_v	100000 lx
λ_d	555.4 nm
P_e	0.4076

Spectral radiation illuminance graph/Peak wavelength spectral radiation illuminance/Illuminance E_v mode

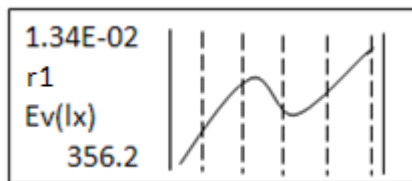

Photosynthetic photon flux density PPF mode

PPFD	2000 umol/m ² /s
------	--------------------------------

MEMO

- [T_{cp}] can be changed to “Color rendering property evaluation R1-R15”.
- In the difference mode, only illuminance is updated.

3. SETTING OPERATION

3.1. FUNCTION MODE

Function mode is used to check and change a lot of data and items stored in the built-in memory of the instrument.

3.1.1. Shifting to function mode/returning to measurement mode

Use the [FUNC.] switch to shift to the function mode and return to the measurement mode. Press the [FUNC.] switch once, and the system shifts to the function mode. Press the switch again, and the system returns to the measurement mode (function mode is canceled).

■ Shifting to function mode

1. Make sure that the instrument is in the standby status.
2. Press the [FUNC.] switch to access the function mode.

 "3.1.2. Set item/Data display"

■ Returning to the measurement mode

Press the [FUNC.] mode again in the function mode. The system exits from the function mode and returns to the measurement mode.

3.1.2. Set item/Data display

In the function mode, the displayed items and data are changed by pressing the [◀] and [▶] switches. The set items and data are shown below.

- Setting the averaging count
 - ☞ “3.2.1. Setting the averaging count”
- Setting ON/OFF of interval mode
 - ☞ “3.2.2. Setting the interval mode”
- Setting the interval measurement conditions
 - ☞ “3.2.3. Setting the interval measurement conditions”
- Setting the manual measurement conditions
 - ☞ “3.2.4. Setting the manual measurement conditions”
- Setting ON/OFF of continuous measurement
 - ☞ “3.2.5. Setting continuous measurement”
- Setting the reference light source
 - ☞ “3.2.6. Setting the reference light source”
- Setting the sample light source
 - ☞ “3.2.7. Setting the sample light source”
- Setting the reference value
 - ☞ “3.2.8. Setting the reference value”
- Setting ON/OFF of the spectral correction factor
 - ☞ “3.2.9. Setting the spectral correction”
- Setting ON/OFF of the tristimulus values correction factor
 - ☞ “3.2.10. Setting the tristimulus values correction”
- Setting ON/OFF of the wireless LAN
 - ☞ “3.2.11. Setting the wireless LAN”
- Setting the wireless LAN IP address
 - ☞ “3.2.12. Setting the wireless LAN IP address”
- Setting the wireless LAN subnet mask
 - ☞ “3.2.13. Setting the wireless LAN subnet mask”
- Setting the wireless LAN port number
 - ☞ “3.2.14. Setting the wireless LAN port number”
- Setting the wireless LAN access point
 - ☞ “3.2.15. Setting the wireless LAN access point”
- Setting the wireless LAN WEP
 - ☞ “3.2.16. Setting the wireless LAN WEP”
- Setting the wireless LAN PASS PHRASE
 - ☞ “3.2.17. Setting the wireless LAN PASS PHRASE”
- Setting the RS-232C baud rate
 - ☞ “3.2.18. Setting the RS-232C baud rate”
- Setting the back light
 - ☞ “3.2.19. Setting the back light”
- Setting the measurement data automatic saving function
 - ☞ “3.2.20. Setting the measurement data automatic saving function”
- Setting the measurement data history clearing function
 - ☞ “3.2.21. Setting the measurement data history clearing function”

3.2. DETAILS OF FUNCTION MODE

To select a proper item, use the [▲] and [▼] switches. To enter a numerical value, specify the digit position with the [◀] and [▶] switches and set a value with the [▲] and [▼] switches.

3.2.1. Setting the averaging count

Set the averaging count.

```
* AVERAGE COUNT *  
  
COUNT = 10
```

Settable range: 1 - 20

* When "1" is set, the average measurement is invalid.

3.2.2. Setting the interval mode

Set ON/OFF of the interval measurement and the system operation if the interval time is exceeded.

```
* INTERVAL MODE *  
  
MODE = OFF  
ERROR STOP = OFF
```

MODE : Set ON/OFF of the interval measurement.

OFF : Invalid

ON : Valid

ERROR STOP : Set whether measurement should continue or stop when the interval time is exceeded.

OFF : Measurement continues.

ON : Measurement stops.

3.2.3. Setting the interval measurement conditions

Set the start delay time, the count and the interval time for interval measurement.

```
* INTERVAL TIME *
  STRAT = 5 s
  COUNT = 10
  TIME  = 8 s
```

START : Set the time until measurement starts since you pressed the [MEAS.] switch.

Settable range: 1 - 180s

COUNT : Set the interval measurement count.

Settable range: 1 - 50

TIME : Set the interval time.

Settable range: 1 - 99s

3.2.4. Setting the manual measurement conditions

Set the measurement range and the integral time for manual measurement.

```
* MANUAL SETTING *
  RANGE 1
  TIME = 100ms
```

RANGE : Set the measurement range.

Settable range: 1 - 4

TIME : Set the integral time.

Settable range: 10 - 20000ms

3.2.5. Setting continuous measurement

Set ON/OFF of continuous measurement.

```
* CONTINUE MEAS *
  ON
```

OFF : Measurement is done once and is finished.

ON : Measurement continues until the [MEAS.] switch is pressed again.

3.2.6. Setting the reference light source

Set the type of the reference light that will be applied to the calculation of color rendering property evaluation.

* STD ILLUMINANTS *
JIS Z 8726

Settable range : JIS Z 8726/Illuminant A/Illuminant D65/Illuminant D50/Illuminant D55/Illuminant D75/Illuminant C

3.2.7. Setting the sample light source

Set the sample light source that will be applied to the calculation of color rendering property evaluation.

* SAMPLE ILLUMINANTS *
Daylight

Daylight : Daylight fluorescent lamp
Other Lamp : Others except daylight fluorescent lamp

3.2.8. Setting the reference value

Set the reference value that will be applied to the difference mode.

* STD SELECT 1 *	
Ev	0.0Ix
x	0.0000
y	0.0000
MEASURE:MEAS	

STD SELECT : Set the reference value registration number.
Settable range: 1 - 3

The setting procedure is shown below.

1. Press the [ENTER] switch and select a registration number with the [▲] and [▼] switches.
2. After selecting, press the [MEAS.] switch to perform measurement.
3. After the measurement, its result is indicated. Press the [ENTER] switch to register the result.



MEMO

The reference value of the indicated number is applied.

3.2.9. Setting the spectral correction

Set whether the correction factor of each wavelength should be applied to the spectral radiation illuminance.

Enter the correction factor directly or set it within 380nm - 780nm at intervals of 1nm through the remote mode.

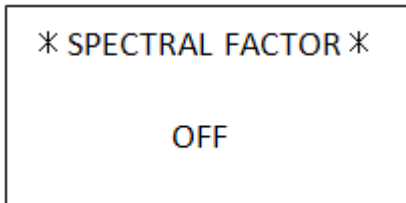

OFF : Spectral correction is not applied.

ON : Spectral correction is applied.

Shift to the direct entry screen for the correction factor of each wavelength. You can change the wavelength with the [◀] and [▶] switches. If you do not enter the correction factor directly, press the [FUNC.] switch.

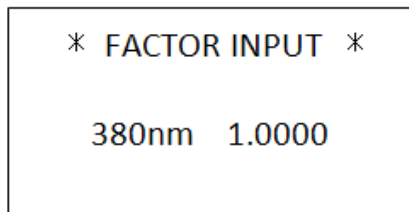

Settable range: 0.0001 - 100.0



You can set the correction factor from the colorimetry program CS-900A.

3.2.10. Setting the tristimulus values correction

Set the correction factor and whether it should be applied to the tristimulus values.

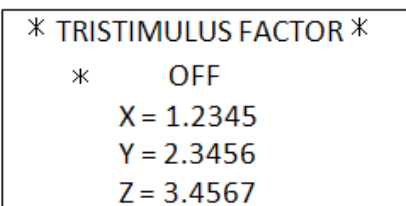

OFF : Tristimulus values correction is not applied.

ON : Tristimulus values correction is applied.

Settable range: 0.0001 - 100.0

3.2.11. Setting the wireless LAN

Set ON/OFF of the wireless LAN function. (only IM-1000)

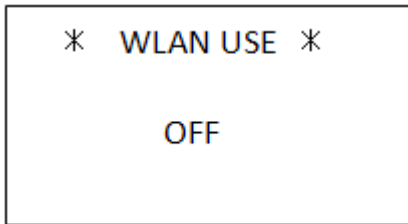

MEMO

- This menu is indicated only in the model having the wireless LAN function.
- After changing the setting, turn on/off the power of the instrument. By turning it on/off, the set data is applied.
- If you use this equipment in the country which does not acquire the wireless LAN standard, be sure to set "OFF" for wireless LAN function.

3.2.12. Setting the wireless LAN IP address

Set the instrument's IP address that will be applied to the wireless LAN communication. (only IM-1000)

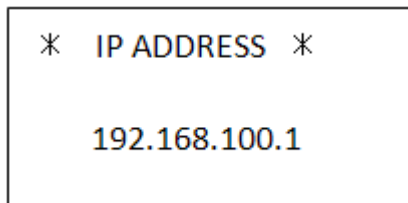

Settable range : 192.168.0.0 - 192.168.255.255

MEMO

- This menu is indicated only in the model having the wireless LAN function.
- After changing the setting, turn on/off the power of the instrument. By turning it on/off, the set data is applied.

3.2.13. Setting the wireless LAN subnet mask

Set the instrument's subnet mask that will be applied to the wireless LAN communication. (only IM-1000)

* SUBNET MASK *
255.255.255.0

Settable range : 255.255.0.0. - 255.255.255.255

 MEMO

- This menu is indicated only in the model having the wireless LAN function.
- After changing the setting, turn on/off the power of the instrument. By turning it on/off, the set data is applied.

3.2.14. Setting the wireless LAN port number

Set the instrument's port number that will be applied to the wireless LAN communication. (only IM-1000)

* PORT SELECT *
50000

Settable range : 49152 - 65535

 MEMO

- This menu is indicated only in the model having the wireless LAN function.
- After changing the setting, turn on/off the power of the instrument. By turning it on/off, the set data is applied.

3.2.15. Setting the wireless LAN access point

Set the access point (SSID) that will be applied to the wireless LAN communication. (only IM-1000)

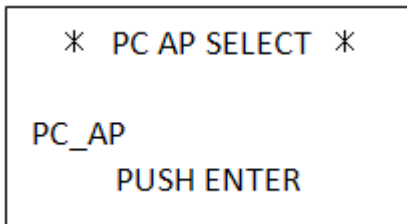

Press the [ENTER] switch, and the access points, which can be connected currently, are indicated. Select and decide a proper access point.

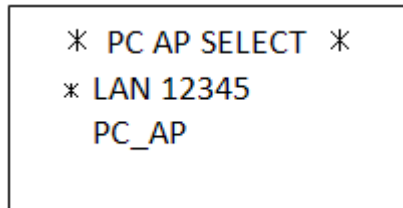
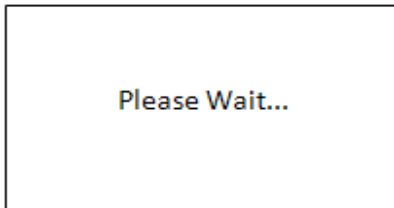

MEMO

- For setting the access point, read the instruction manual of the connected device at the same time.
- If the access point is not changed, it is not necessary to set it at each measurement. Set the access point only when it must be changed.
- This menu is indicated only in the model having the wireless LAN function.
- After changing the setting, turn on/off the power of the instrument. By turning it on/off, the set data is applied.

3.2.16. Setting the wireless LAN WEP

Set WEP (Wired Equivalent Privacy Key) that will be applied to the wireless LAN communication. (only IM-1000)

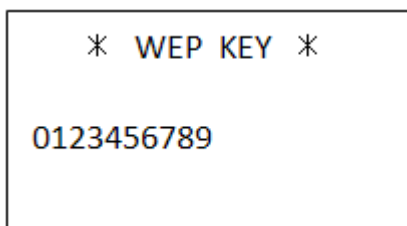

MEMO

- For setting WEP, read the instruction manual of the connected device at the same time.
- This menu is indicated only in the model having the wireless LAN function.
- After changing the setting, turn on/off the power of the instrument. By turning it on/off, the set data is applied.

3.2.17. Setting the wireless LAN PASS PHRASE

Set PASS PHRASE that will be applied to the wireless LAN communication. (only IM-1000)

* PASS PHRASE *
0123456789

Settable range : 63 letters or less

 MEMO

- For setting PASS PHRASE, read the instruction manual of the connected device at the same time.
- This menu is indicated only in the model having the wireless LAN function.
- After changing the setting, turn on/off the power of the instrument. By turning it on/off, the set data is applied.

3.2.18. Setting the RS-232C baud rate

Set the baud rate that will be applied to the RS-232C communication.

* BAUD RATE *
38400

Settable range: 38400/19200/9600

 MEMO

After changing the setting, turn on/off the power of the instrument. By turning it on/off, the set data is applied.

3.2.19. Setting the back light

Set ON/OFF of the back light in the liquid crystal display unit.

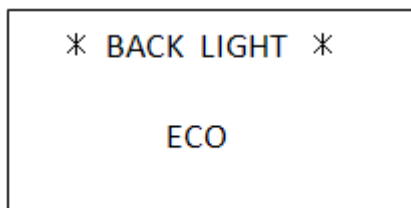

OFF : The back light is always OFF.

ON : The back light is always ON.

ECO : When measurement is being done and when the instrument is not operated for 1 minute or more, the back light is OFF.

Right after measurement has been finished and when any switch is pressed, the back light is ON.



MEMO

If turning on the back light only is necessary in the [ECO] mode, press the [ENTER] switch.

3.2.20. Setting the measurement data automatic saving function

Set ON/OFF of the measurement data automatic saving function.

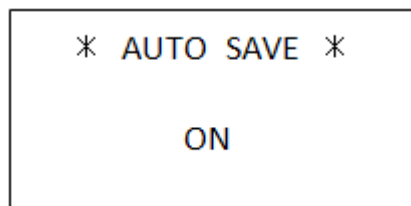

OFF : The data is not automatically saved.

ON : The data is automatically saved at each measurement.



MEMO

When the automatic saving function is ON, the data is written in the internal memory at each measurement. So it takes longer time until the measurement is finished.

3.2.21. Setting the measurement data history clearing function

Clear the history of all the measurement data that are saved in the instrument's internal memory.

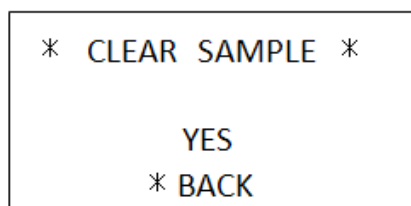

YES : Clear the history of all the measurement data.

BACK : Cancels the function mode.

4. COMMUNICATION WITH PERSONAL COMPUTER

4.1. COMMUNICATION COMMAND

The instrument (IM-1000) can communicate with a personal computer by using RS-232C and wireless LAN.

This chapter will explain the commands that will be used when the customer makes a peculiar program for the communication with the instrument.

* The values are fixed for the following items.

Data bit: 7

Stop bit: 1



Parity: Odd number (ODD)

Delimiter: CR: 0x0d, LF: 0x0a

Use the RS-232C communication cable exclusively for the instrument.

4.2. COMMAND LIST

The communication commands and their functions are shown below. “_” means a space and “#” means a numerical value.

Communication command	Function
RM	Set the remote mode.
LM	Set the local mode. (The remote mode is canceled.)
WHO	Obtain the model name.
VER	Obtain the software version.
SRL	Obtain the serial number.
ST	Execute measurement. When measurement is finished, the measurement data is sent back. Only the colorimetry data, spectral radiation illuminance and color rendering property evaluation are sent back.  “4.4 MEASUREMENT DATA OUTPUT FORMAT”
ST2	Execute measurement. When measurement is finished, the measurement data is sent back. Only colorimetry data is sent back.  “4.4 MEASUREMENT DATA OUTPUT FORMAT”

Communication command	Function
ST3	<p>Execute measurement. When measurement is finished, the measurement data is sent back. Only the colorimetry data and color rendering property evaluation are sent back.</p> <p>☞ “4.4 MEASUREMENT DATA OUTPUT FORMAT”</p>
SP	<p>Execute measurement. When measurement is finished, the measurement data is sent back. All the measurement data are sent back.</p> <p>☞ “4.4 MEASUREMENT DATA OUTPUT FORMAT”</p>
SP2	<p>Execute measurement. When measurement is finished, the measurement data is sent back. Only the colorimetry data and photosynthetic photon flux density are sent back.</p> <p>☞ “4.4 MEASUREMENT DATA OUTPUT FORMAT”</p>
CST	<p>Start continuous measurement. The data of each measurement is not sent back. Obtain the measurement data with the “STR*” command. If you send this command during continuous measurement, “NO” is returned.</p>
STP	<p>Stop continuous measurement. If you send this command during continuous measurement, continuous measurement stops.</p>
STR_#	<ul style="list-style-type: none"> - Obtain the data of the specified number from the measurement history while measurement is in the stop status. Settable range: 1 - 50 (“1” is the newest data.) - Obtain the newest data during continuous measurement. It is not necessary to specify the measurement history number. Send the “STR” command only. <p>Obtain the colorimetry data, spectral radiation illuminance and color rendering property evaluation. You cannot obtain the photosynthetic photon flux density.</p> <p>☞ “4.4 MEASUREMENT DATA OUTPUT FORMAT”</p>
STR2_#	<ul style="list-style-type: none"> - Obtain the data of the specified number from the measurement history while measurement is in the stop status. Settable range: 1 - 50 (“1” is the newest data.) - Obtain the newest data during continuous measurement. It is not necessary to specify the measurement history number. Send the “STR2” command only. <p>Obtain the colorimetry data only. You cannot obtain the spectral radiation illuminance, color rendering property evaluation and photosynthetic photon flux density.</p> <p>☞ “4.4 MEASUREMENT DATA OUTPUT FORMAT”</p>

Communication command	Function
STR3_#	<ul style="list-style-type: none"> - Obtain the data of the specified number from the measurement history while measurement is in the stop status. Settable range: 1 - 50 ("1" is the newest data.) - Obtain the newest data during continuous measurement. It is not necessary to specify the measurement history number. Send the "STR3" command only. <p>Obtain the colorimetry data and color rendering property evaluation. You cannot obtain the spectral radiation illuminance and photosynthetic photon flux density.</p> <p>☞ "4.4 MEASUREMENT DATA OUTPUT FORMAT"</p>
SPR_#	<ul style="list-style-type: none"> - Obtain the data of the specified number from the measurement history while measurement is in the stop status. Settable range: 1 - 50 ("1" is the newest data.) - Obtain the newest data during continuous measurement. It is not necessary to specify the measurement history number. Send the "SPR" command only. <p>Obtain the all measurement data.</p> <p>☞ "4.4 MEASUREMENT DATA OUTPUT FORMAT"</p>
SPR2_#	<ul style="list-style-type: none"> - Obtain the data of the specified number from the measurement history while measurement is in the stop status. Settable range: 1 - 50 ("1" is the newest data.) - Obtain the newest data during continuous measurement. It is not necessary to specify the measurement history number. Send the "SPR2" command only. <p>Obtain the colorimetry data and photosynthetic photon flux density. You cannot obtain the spectral radiation illuminance and color rendering property evaluation.</p> <p>☞ "4.4 MEASUREMENT DATA OUTPUT FORMAT"</p>
MG_#	<p>Set the measurement range mode.</p> <p>0: AUTO FULL (FL) 1: AUTO FIRST (FS) 2: AUTO ADJUST (AJ) 3: MANUAL RANGE (ML) 4: MANUAL INTEG (MI)</p> <p>☞ "1.2.1. Names and functions of switches on keyboard"</p>
MRW_#	<p>Set the measurement range when [MANUAL RANGE] is set.</p> <p>1: Range 1 2: Range 2 3: Range 3 4: Range 4</p>
MRR	<p>Obtain the measurement range when [MANUAL RANGE] is set.</p>
MTW_##	<p>Set the integral time when [MANUAL RANGE] is set.</p> <p>Settable range: 10 - 20000ms</p>
MTR	<p>Obtain the integral time when [MANUAL RANGE] is set.</p>
FO_#	<p>Set ON/OFF of spectral correction.</p> <p>0: OFF 1: ON</p>
FOR	<p>Obtain the ON/OFF data of spectral correction.</p>
FW_#_#####	<p>Set the spectral correction factor (within 380 - 780nm at intervals of 1nm).</p> <p>0: 380nm - 400: 780nm</p> <p>Settable range: 0.0001 - 100.0</p>

Communication command	Function
FR_#	Obtain the spectral correction factor (within 380 - 780nm at intervals of 1nm). 0: 380nm - 400: 780nm
TRW_#	Set ON/OFF of the tristimulus values. 0: OFF 1: ON
TRR	Obtain the ON/OFF data of tristimulus values.
XW_#####	Set the correction factor of the tristimulus value X. Settable range: 0.0001 - 100.0
XR	Obtain the correction factor of the tristimulus value X.
YW_#####	Set the correction factor of the tristimulus value Y. Settable range: 0.0001 - 100.0
YR	Obtain the correction factor of the tristimulus value Y.
ZW_#####	Set the correction factor of the tristimulus value Z. Settable range: 0.0001 - 100.0
ZR	Obtain the correction factor of the tristimulus value Z.
BRW_#	Set the baud rate of RS-232C. 0: 9600 1: 19200 2: 38400
BRR	Obtain the baud rate of RS-232C.
ACW_##	Set the averaging count. Settable range: 1 - 20 When "1" is set, the average measurement is invalid.
ACR	Obtain the averaging count in average measurement.
ERR	Obtain the newest error number and message.

4.3. COMMUNICATION PROTOCOL

The protocols for the RS-232C/wireless LAN communication (only IM-1000) are shown below.

The instrument (IM-1000) sends the following answers as the responses to all the commands.

- “OK” when the command is normally received
- “NO” when the command cannot be analyzed
- “NG” when the command is normally received but the processing is not normal

“_” means a space and “#” means a numerical value.

MEMO

When sending the commands continuously, set an interval of at least 3ms between the sending actions.

4.3.1. RM command

Set the remote mode.

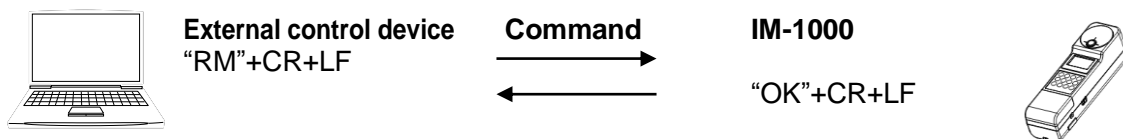

4.3.2. LM command

Set the local mode.

When the instrument receives this command while the local mode is set, it sends back “NO”.

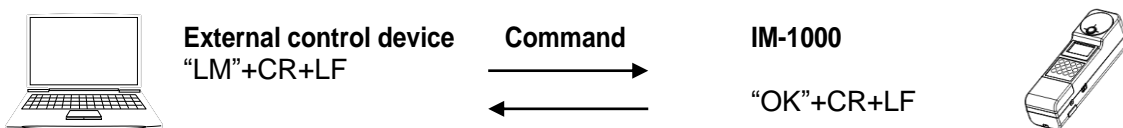

4.3.3. WHO command

Obtain a model name.

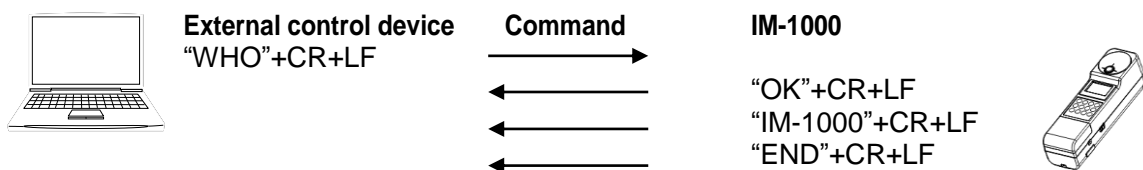

4.3.4. VER command

Obtain the software version.
Obtainable range: 1.00 - 99.99



External control device
"VER"+CR+LF

Command

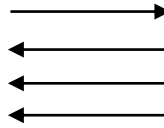

IM-1000

"OK"+CR+LF
"1.00"+CR+LF
"END"+CR+LF



4.3.5. SRL command

Obtain the serial number.
Obtainable range: 00000000 - 99999999



External control device
"SRL"+CR+LF

Command

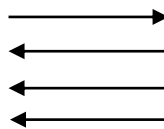

IM-1000

"OK"+CR+LF
"12345678"+CR+LF
"END"+CR+LF



4.3.6. ST command

As soon as the instrument receives this command, it starts measurement according to the measurement conditions already set. When the measurement is finished, the measurement data is sent according to “4.4. MEASUREMENT DATA OUTPUT FORMAT”.

- Sending from the external control device to the instrument

The external control device (PC or PLC, etc.) sends the character line “ST” (0x53/0x54) with CR (0x0d) and LF (0x0a) via RS-232C or wireless LAN.

- Sending from the instrument to the external control device

The instrument recognizes “ST” and sends back “OK” with CR and LF as the command recognition normal response. At the same time measurement starts.

When the measurement is normally finished, the measurement data is sent back according to “■ ST, STR command measurement data format” of “4.4 MEASUREMENT DATA OUTPUT FORMAT”. If an error occurs during measurement, “NG” with CR and LF is sent back. When the external control device receives “NG”, it sends “ERR” with CR and LF and you can check the contents of the error.

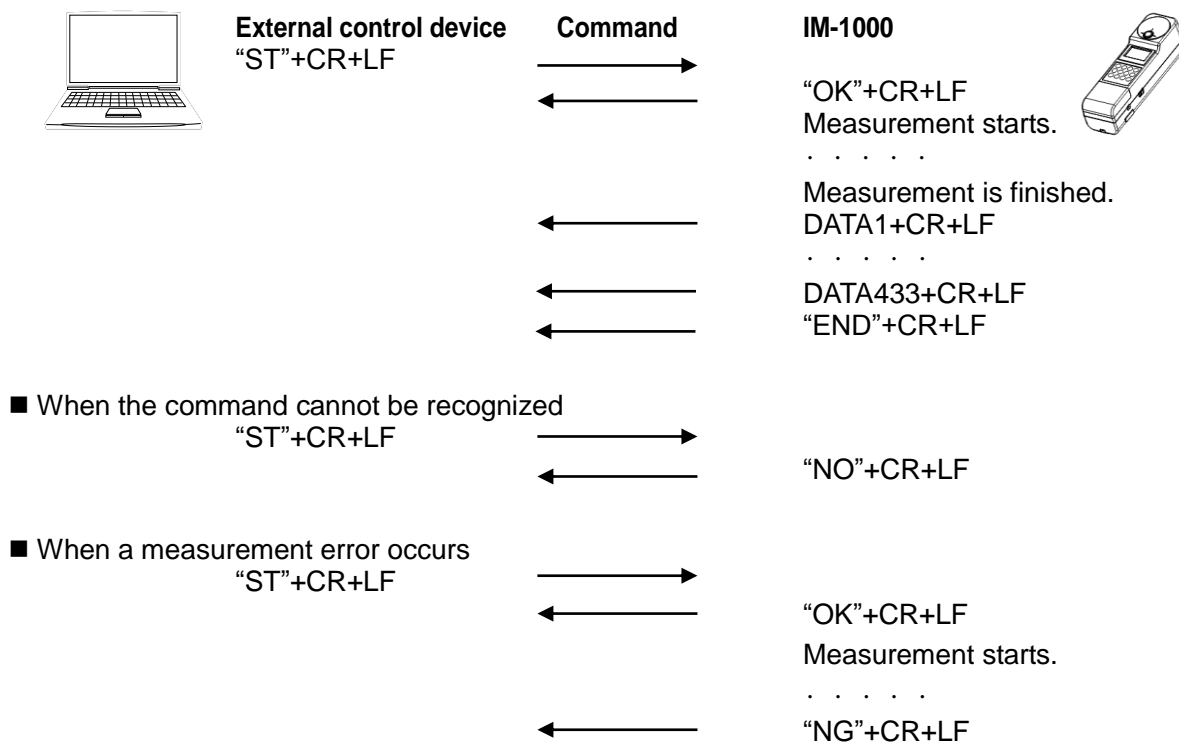

* Only the colorimetry, spectral radiation illuminance and color rendering property evaluation are output. The photosynthetic photon flux density is not output.

4.3.7. ST2 command

As soon as the instrument receives this command, it starts measurement according to the measurement conditions already set. When the measurement is finished, the measurement data is sent back according to “■ ST2, STR2 command measurement data format” of “4.4. MEASUREMENT DATA OUTPUT FORMAT”.

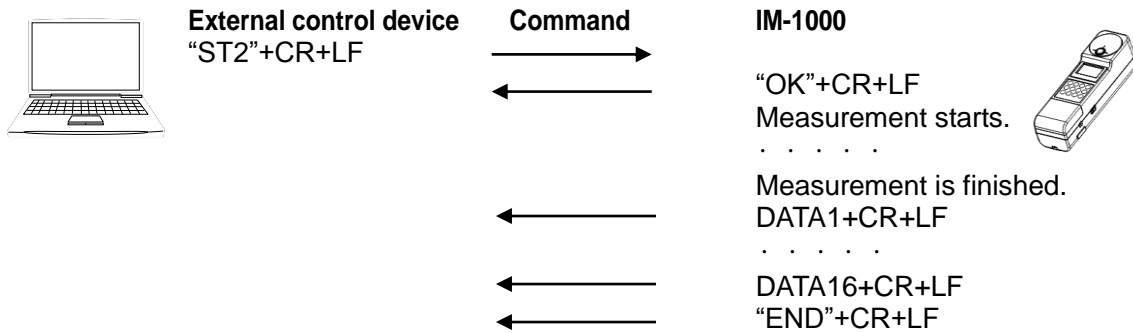

* Only the colorimetry is output. The spectral radiation illuminance, color rendering property evaluation and photosynthetic photon flux density are not output.

4.3.8. ST3 command

As soon as the instrument receives this command, it starts measurement according to the measurement conditions already set. When the measurement is normally finished, the measurement data is sent back according to “■ ST3, STR3 command measurement data format” of “4.4. MEASUREMENT DATA OUTPUT FORMAT”.

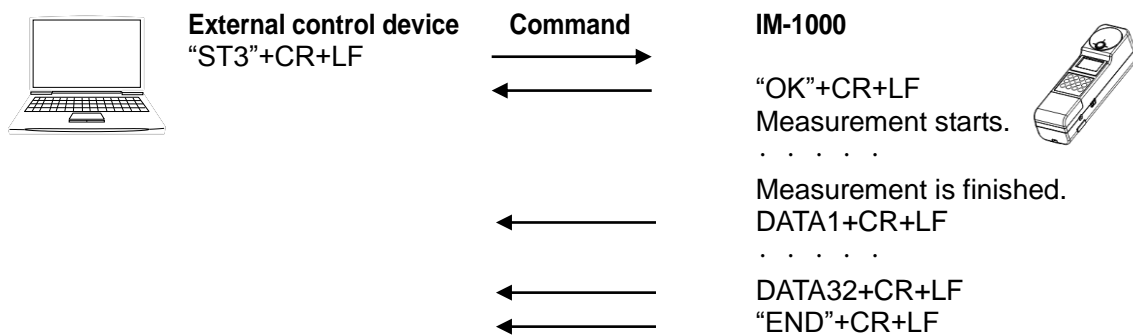

* Only the colorimetry and color rendering property evaluation are output. The spectral radiation illuminance and photosynthetic photon flux density are not output.

4.3.9. SP command

As soon as the instrument receives this command, it starts measurement according to the measurement conditions already set. When the measurement is finished, the measurement data is sent according to “4.4. MEASUREMENT DATA OUTPUT FORMAT”.

- Sending from the external control device to the instrument

The external control device (PC or PLC, etc.) sends the character line “ST” (0x53/0x54) with CR (0x0d) and LF (0x0a) via RS-232C or wireless LAN.

- Sending from the instrument to the external control device

The instrument recognizes “SP” and sends back “OK” with CR and LF as the command recognition normal response. At the same time measurement starts.

When the measurement is normally finished, the measurement data is sent back according to “■ SP, SPR command measurement data format” of “4.4 MEASUREMENT DATA OUTPUT FORMAT”. If an error occurs during measurement, “NG” with CR and LF is sent back. When the external control device receives “NG”, it sends “ERR” with CR and LF and you can check the contents of the error.

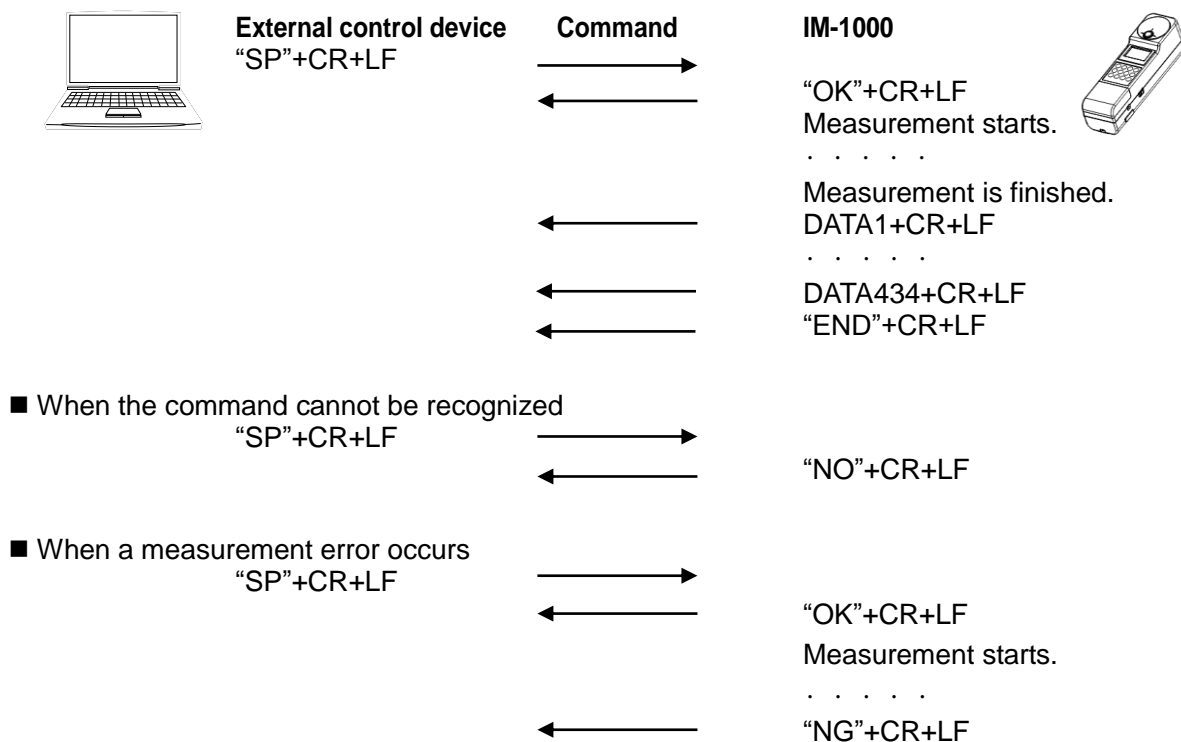

* All the data (colorimetry, spectral radiation illuminance, color rendering property evaluation and photosynthetic photon flux density) are output.

4.3.10. SP2 command

As soon as the instrument receives this command, it starts measurement according to the measurement conditions already set. When the measurement is finished, the measurement data is sent back according to "■ SP2, SPR2 command measurement data format" of "4.4. MEASUREMENT DATA OUTPUT FORMAT".

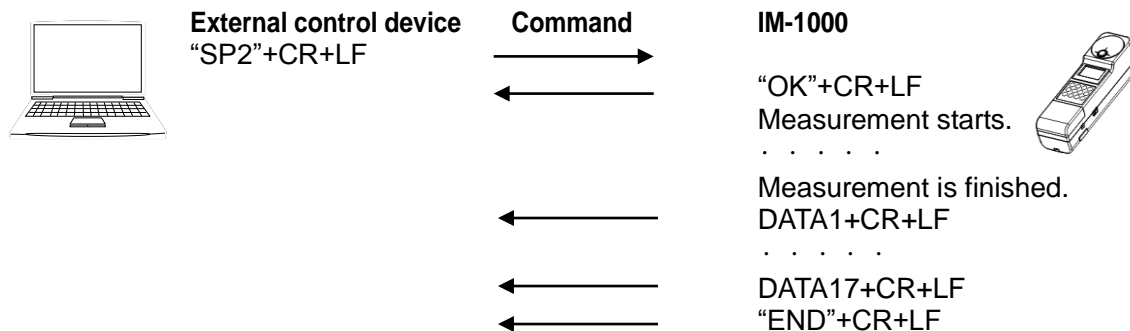

* Only the colorimetry and photosynthetic photon flux density are output. The spectral radiation illuminance and color rendering property evaluation and are not output.

4.3.11. CST command

When the instrument receives this command while measurement is in the stop status, it starts continuous measurement at once according to the measurement conditions already set. The data of each measurement is not sent back. Obtain the measurement data with the "STR", "STR2" and "STR3" commands.

When the instrument receives this command during continuous measurement, it sends back "NO".

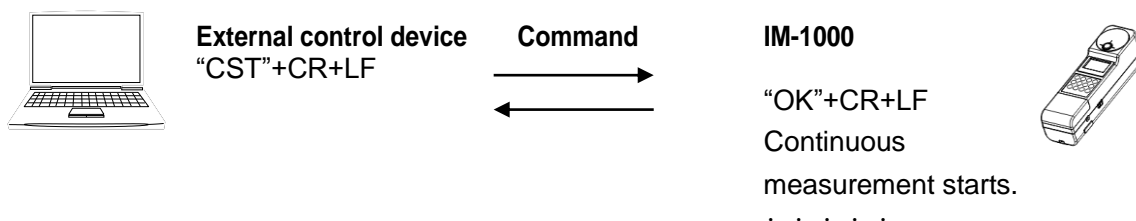

4.3.12. STP command

When the instrument receives this command during continuous measurement, it stops the continuous measurement. Sometimes it takes long time until the measurement stops due to the receiving time status.

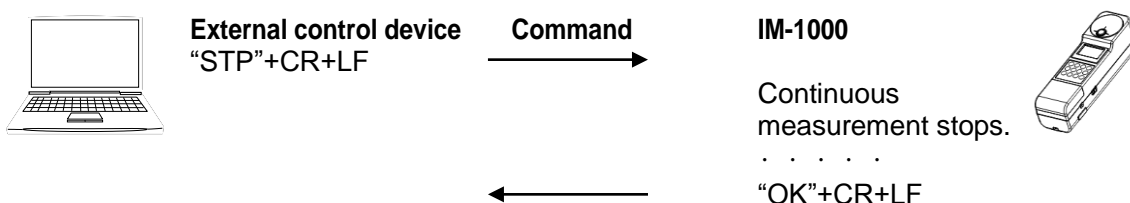

4.3.13. STR_# command

When the instrument receives this command while measurement is in the stop status, the specified number data saved in the instrument is output. The measurement data number is “No.1” (newest) to “No.50”.

Obtainable range: 1 (newest) - 50

- When measurement is in the stop status

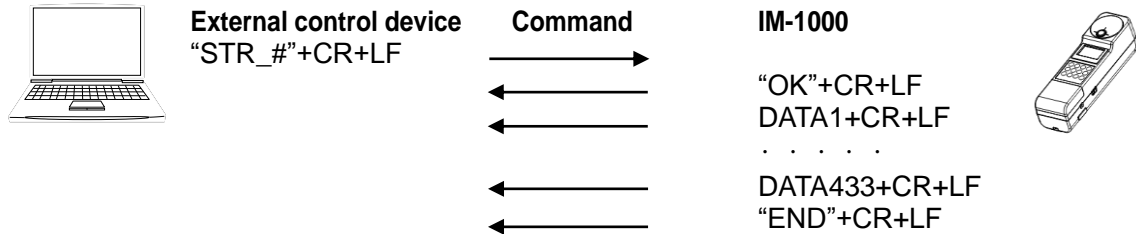

When the instrument receives this command during continuous measurement, the newest measurement data is output. **It is not necessary to specify the measurement data number.**

- When the instrument is performing measurement continuously

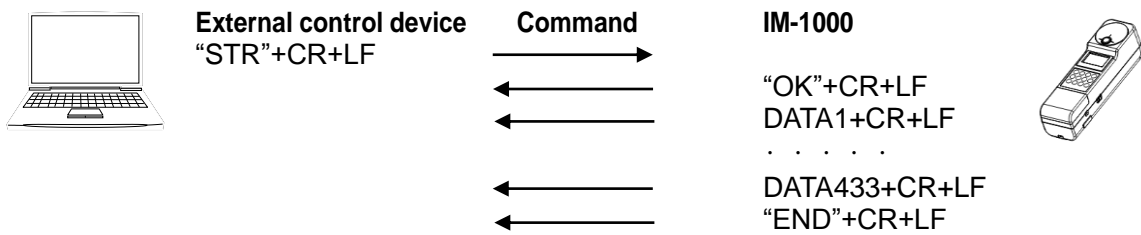

* Only the colorimetry, spectral radiation illuminance and color rendering property evaluation are output. The photosynthetic photon flux density is not output.

4.3.14. STR2_# command

When the instrument receives this command while measurement is in the stop status, the specified number data saved in the instrument is output. The measurement data number is “No.1” (newest) to “No.50”.

Obtainable range: 1 (newest) - 50

- When measurement is in the stop status

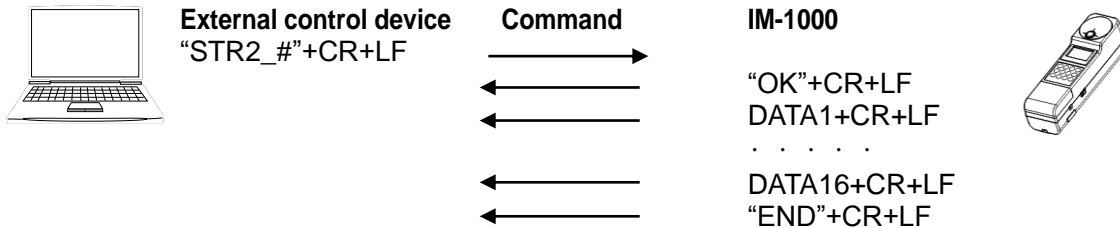

When the instrument receives this command during continuous measurement, the newest measurement data is output. It is not necessary to specify the measurement data number.

- When the instrument is performing measurement continuously

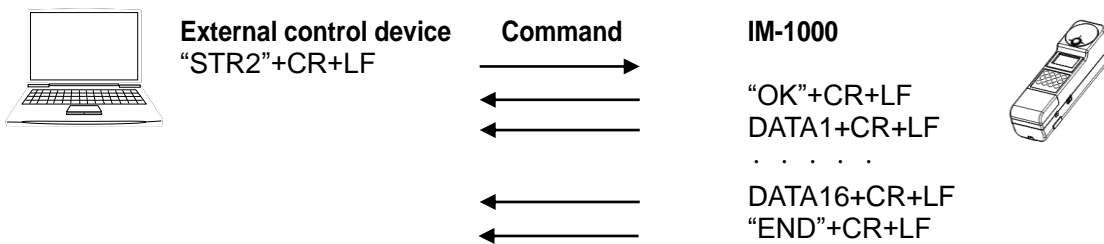

* Only the colorimetry is output. The spectral radiation illuminance, color rendering property evaluation and photosynthetic photon flux density are not output.

4.3.15. STR3_# command

When the instrument receives this command while measurement is in the stop status, the specified number data saved in the instrument is output. The measurement data number is “No.1” (newest) to “No.50”.

Obtainable range: 1 (newest) - 50

- When measurement is in the stop status

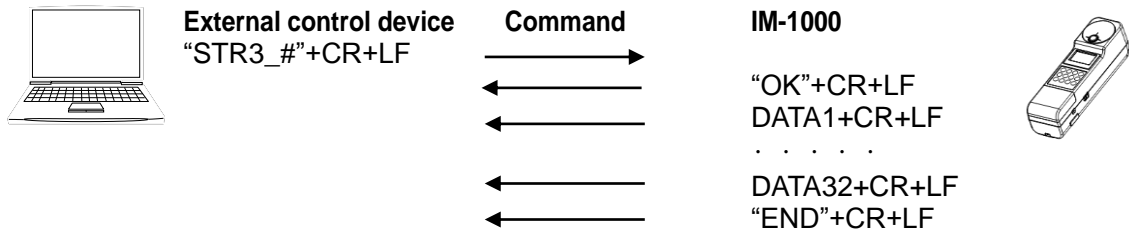

When the instrument receives this command during continuous measurement, the newest measurement data is output. **It is not necessary to specify the measurement data number.**

- When the instrument is performing measurement continuously

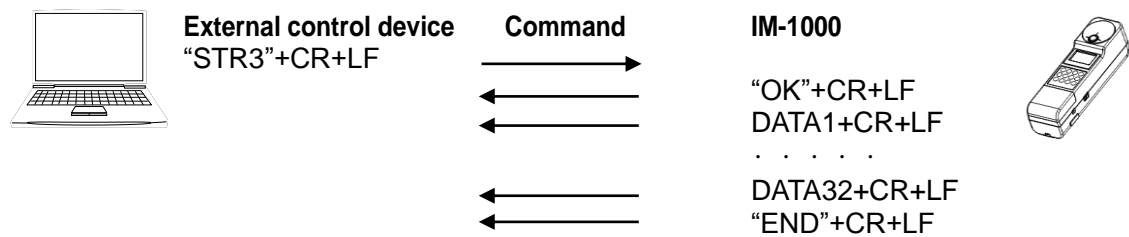

* Only the colorimetry and color rendering property evaluation are output. The spectral radiation illuminance and photosynthetic photon flux density are not output.

4.3.16. SPR_# command

When the instrument receives this command while measurement is in the stop status, the specified number data saved in the instrument is output. The measurement data number is “No.1” (newest) to “No.50”.

Obtainable range: 1 (newest) - 50

- When measurement is in the stop status

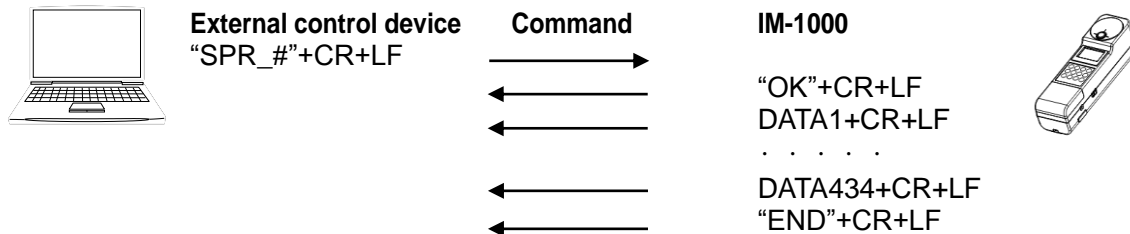

When the instrument receives this command during continuous measurement, the newest measurement data is output. **It is not necessary to specify the measurement data number.**

- When the instrument is performing measurement continuously

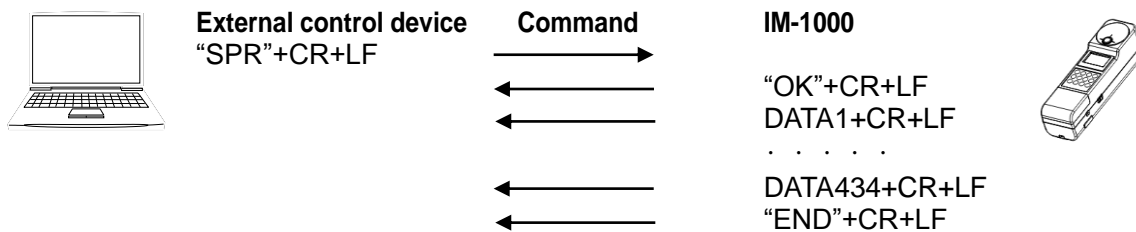

* All the data (colorimetry, spectral radiation illuminance, color rendering property evaluation and photosynthetic photon flux density) are output.

4.3.17. SPR2_# command

When the instrument receives this command while measurement is in the stop status, the specified number data saved in the instrument is output. The measurement data number is “No.1” (newest) to “No.50”.

Obtainable range: 1 (newest) - 50

- When measurement is in the stop status

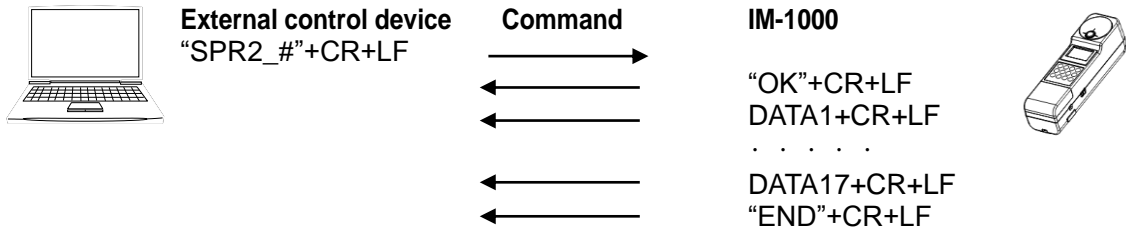

When the instrument receives this command during continuous measurement, the newest measurement data is output. It is not necessary to specify the measurement data number.

- When the instrument is performing measurement continuously

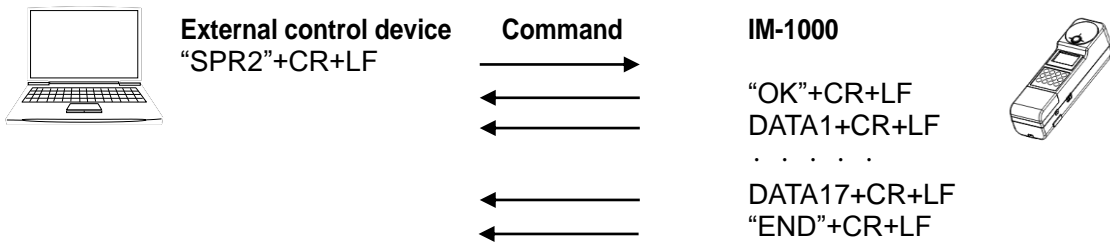

* Only the colorimetry and photosynthetic photon flux density are output. The spectral radiation illuminance and color rendering property evaluation are not output.

4.3.18. MG_# command

Set the measurement range mode.

Settable range 0: AUTO FULL 1: AUTO FIRST 2: AUTO ADJUST
3: MANUAL RANGE 4: MANUAL INTEG



External control device
"MG_#" + CR + LF

Command

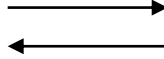

IM-1000

"OK" + CR + LF



3.3.19. MRW_# command

Set the measurement range for the "MANUAL RANGE" measurement.

Settable range 1: Range 1 2: Range 2 3: Range 3 4: Range 4



External control device
"MRW_####" + CR + LF

Command

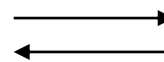

IM-1000

"OK" + CR + LF



4.3.20. MRR command

Obtain the measurement range for the "MANUAL RANGE" measurement.

Obtainable range 1: Range 1 2: Range 2 3: Range 3 4: Range 4



External control device
"MRR" + CR + LF

Command

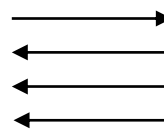

IM-1000

"OK" + CR + LF

"1" + CR + LF

"END" + CR + LF



4.3.21. MTW_## command

Set the integral time for the "MANUAL RANGE" measurement.

Settable range: 10 - 20000ms



External control device
"MTW_##" + CR + LF

Command

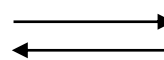

IM-1000

"OK" + CR + LF



4.3.22. MTR command

Obtain the integral time for the "MANUAL RANGE" measurement.
Obtainable range: 10 - 2000ms

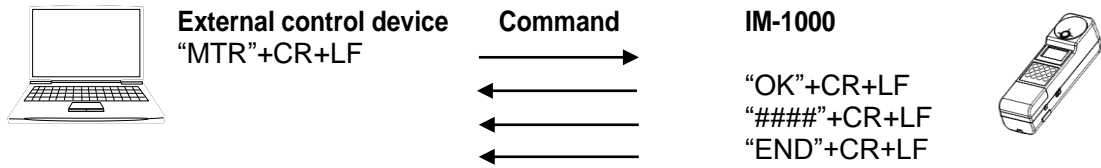

4.3.23. FO_# command

Set ON/OFF of the spectral correction factor.
Settable range 0: OFF 1: ON

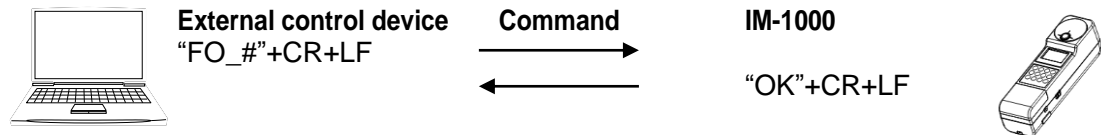

4.3.24. FOR command

Obtain the ON/OFF data of the spectral correction factor.
Obtainable range 0: OFF 1: ON

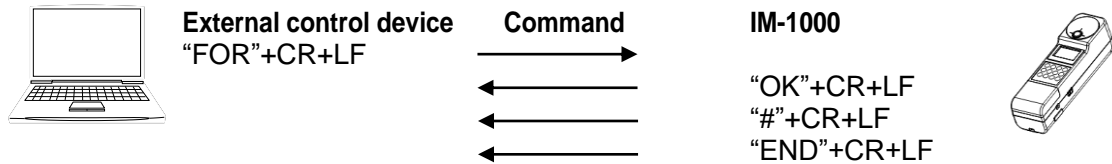

4.3.25. FW_##_#### command

Set the spectral correction factor at intervals of 1nm.
Settable range 1: 0:380nm - 400:780nm
Settable range 2: 0.0001 - 100.0

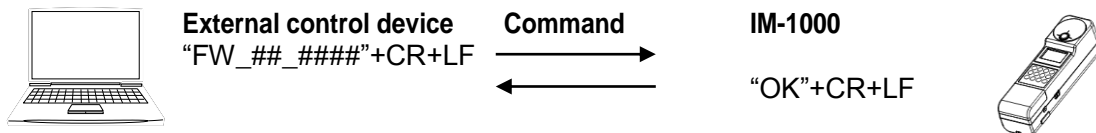

4.3.26. FR_## command

Obtain the spectral correction factor at intervals of 1nm.
Obtainable range: 0:380nm - 400:780nm

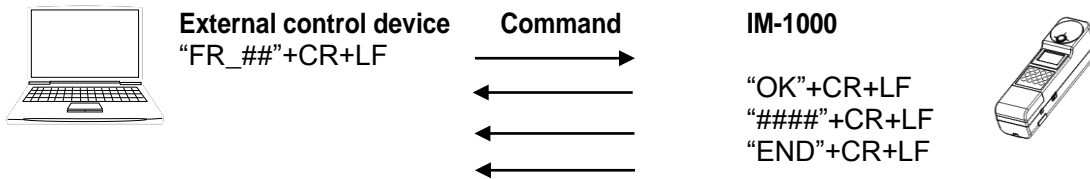

4.3.27. TRW_# command

Set ON/OFF of the tristimulus values correction factor.
Settable range 0: OFF 1: ON

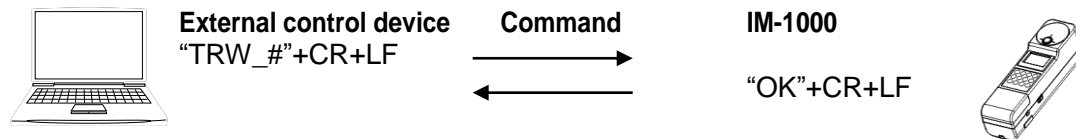

4.3.28. TRR command

Obtain the ON/OFF data of the tristimulus values correction factor.
Obtainable range 0: OFF 1: ON

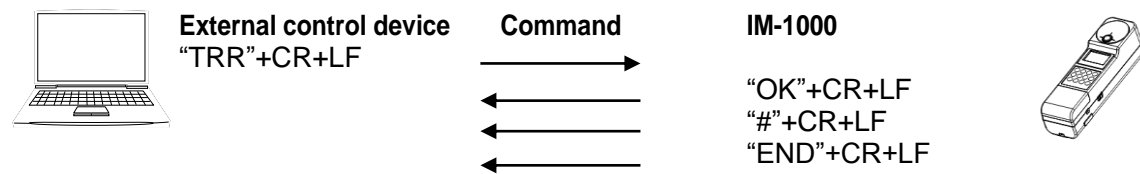

4.3.29. XW, YW, ZW_##_#### command

Set the correction factors of the tristimulus values XYZ.
Settable range: 0.0001 - 100.0

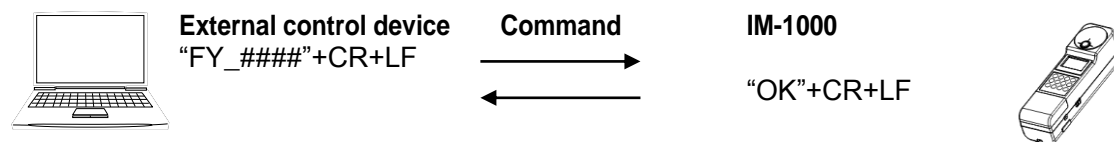

4.3.30. XR, YR, ZR command

Obtain the correction factors of the tristimulus values XYZ.
Obtainable range: 0.0001 - 100.0

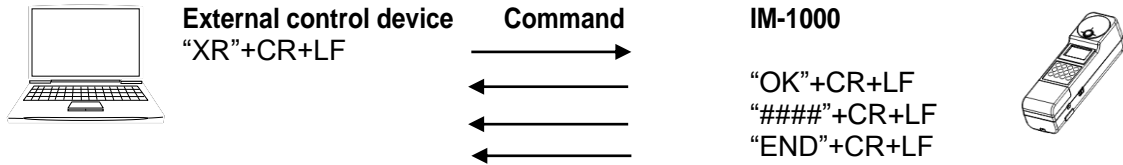

4.3.31. BRW_# command

Set the baud rate for the RS-232C communication.
Settable range 0: 9600 1: 19200 2: 38400

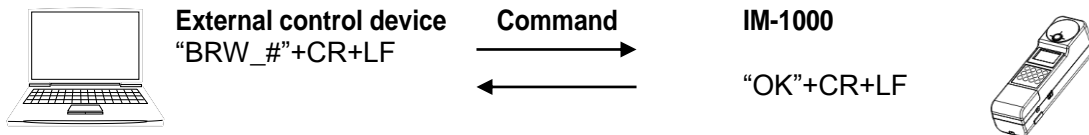

4.3.32. BRR command

Obtain the baud rate for the RS-232C communication.
Obtainable range 0: 9600 1: 19200 2: 38400

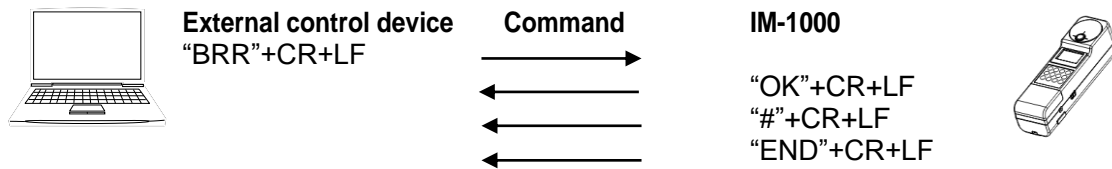

4.3.33. ACW_## command

Set the averaging count.
Settable range: 1 - 20

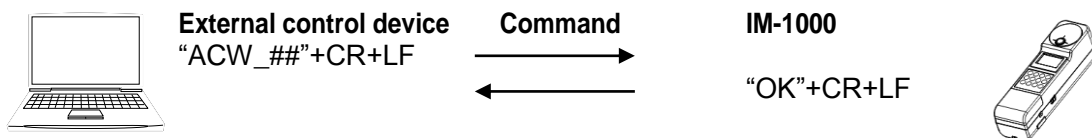

4.3.34. ACR command

Obtain the averaging count.

Obtainable range: 1 - 20



External control device
"ACR"+CR+LF

Command

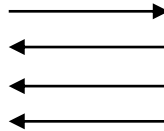

IM-1000

"OK"+CR+LF
"##"+CR+LF
"END"+CR+LF



4.3.35. ERR command

Obtain the newest error number and message.

Obtainable range 1: 0 - 999

Obtainable range 2: Maximum 20 bytes



External control device
"ERR"+CR+LF

Command

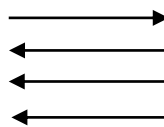

IM-1000

"OK"+CR+LF
"12:over range error"+CR+LF
"END"+CR+LF



4.4. MEASUREMENT DATA OUTPUT FORMAT

The formats to output the measurement data from the instrument are shown below.

The measurement data format is changed according to the measurement commands and the measurement data obtaining commands.

■ ST, STR command measurement data format

No.	Item	Unit	Example of output	Remarks
1	Measurement range	-	1	
2	Integral time	ms	150	Unit: 1ms
3	Radiant illuminance	W/m ²	2.495E-05	Valid digit of index: 4 digits
4	Illuminance	lx	143.5	Valid digit: Upper 4 digits In the case of 999 or less, the numeral at the first decimal place is indicated.
5	Tristimulus value X	-	144.1	↓
6	Tristimulus value Y	-	143.5	↓
7	Tristimulus value Z	-	83.1	↓
8	Chromaticity x	-	0.3885	To the fourth decimal place
9	Chromaticity y	-	0.3872	↓
10	Chromaticity u'	-	0.2262	↓
11	Chromaticity v'	-	0.5073	↓
12	Correlated color temperature	K	3868	
13	Deviation	-	0.0026	To the fourth decimal place
14	Dominant wavelength	nm	578.3	To the first decimal place
15	Excitation purity	-	0.3281	To the fourth decimal place
16	Peak wavelength	nm	555	
17	Spectral radiation illuminance 380nm	W/(m ² · nm)	2.495E-04	Valid digit of index: 4 digits
↓	↓	↓	↓	↓
417	Spectral radiation illuminance 780nm	W/(m ² · nm)	1.736E-02	↓
418	Average color rendering property evaluation Ra	-	89	
419	Color rendering property evaluation R1	-	76	
↓	↓	↓	↓	
↓	Color rendering property evaluation R8	-	98	
↓	Special color rendering property evaluation R9	-	84	
↓	↓	↓	↓	
433	Special color rendering property evaluation R15	-	64	
434	Data end	-	"END"	End command

* 434 items are fixed for output. If the measured value is not normal, "*****" is output for the item.

■ ST2, STR2 command measurement data format

No.	Item	Unit	Example of output	Remarks
1	Measurement range	-	1	
2	Integral time	ms	150	Unit: 1ms
3	Radiant illuminance	W/m ²	2.495E-05	Valid digit of index: 4 digits
4	Illuminance	lx	143.5	Valid digit: Upper 4 digits In the case of 999 or less, the numeral at the first decimal place is indicated.
5	Tristimulus value X	-	144.1	↓
6	Tristimulus value Y	-	143.5	↓
7	Tristimulus value Z	-	83.1	↓
8	Chromaticity x	-	0.3885	To the fourth decimal place
9	Chromaticity y	-	0.3872	↓
10	Chromaticity u'	-	0.2262	↓
11	Chromaticity v'	-	0.5073	↓
12	Correlated color temperature	K	3868	
13	Deviation	-	0.0026	To the fourth decimal place
14	Dominant wavelength	nm	578.3	To the first decimal place
15	Excitation purity	-	0.3281	To the fourth decimal place
16	Peak wavelength	nm	555	
17	Data end	-	"END"	End command

* 17 items are fixed for output. If the measured value is not normal, "*****" is output for the item.

■ ST3, STR3 command measurement data format

No.	Item	Unit	Example of output	Remarks
1	Measurement range	-	1	
2	Integral time	ms	150	Unit: 1ms
3	Radiant illuminance	W/m ²	2.495E-05	Valid digit of index: 4 digits
4	Illuminance	lx	143.5	Valid digit: Upper 4 digits In the case of 999 or less, the numeral at the first decimal place is indicated.
5	Tristimulus value X	-	144.1	↓
6	Tristimulus value Y	-	143.5	↓
7	Tristimulus value Z	-	83.1	↓
8	Chromaticity x	-	0.3885	To the fourth decimal place
9	Chromaticity y	-	0.3872	↓
10	Chromaticity u'	-	0.2262	↓
11	Chromaticity v'	-	0.5073	↓
12	Correlated color temperature	K	3868	
13	Deviation	-	0.0026	To the fourth decimal place
14	Dominant wavelength	nm	578.3	To the first decimal place
15	Excitation purity	-	0.3281	To the fourth decimal place
16	Peak wavelength	nm	555	
17	Average color rendering property evaluation Ra	-	89	
18	Color rendering property evaluation R1	-	76	
↓	↓	↓	↓	
↓	Color rendering property evaluation R8	-	98	
↓	Special color rendering property evaluation R9	-	84	
↓	↓	↓	↓	
32	Special color rendering property evaluation R15	-	64	
33	Data end	-	"END"	End command

* 33 items are fixed for output. If the measured value is not normal, "*****" is output for the item.

■ SP, SPR command measurement data format

No.	Item	Unit	Example of output	Remarks
1	Measurement range	-	1	
2	Integral time	ms	150	Unit: 1ms
3	Radiant illuminance	W/m ²	2.495E-05	Valid digit of index: 4 digits
4	Illuminance	lx	143.5	Valid digit: Upper 4 digits In the case of 999 or less, the numeral at the first decimal place is indicated.
5	Tristimulus value X	-	144.1	↓
6	Tristimulus value Y	-	143.5	↓
7	Tristimulus value Z	-	83.1	↓
8	Chromaticity x	-	0.3885	To the fourth decimal place
9	Chromaticity y	-	0.3872	↓
10	Chromaticity u'	-	0.2262	↓
11	Chromaticity v'	-	0.5073	↓
12	Correlated color temperature	K	3868	
13	Deviation	-	0.0026	To the fourth decimal place
14	Dominant wavelength	nm	578.3	To the first decimal place
15	Excitation purity	-	0.3281	To the fourth decimal place
16	Peak wavelength	nm	555	
17	Spectral radiation illuminance 380nm	W/(m ² · nm)	2.495E-04	Valid digit of index: 4 digits
↓	↓	↓	↓	↓
417	Spectral radiation illuminance 780nm	W/(m ² · nm)	1.736E-02	↓
418	Average color rendering property evaluation Ra	-	89	
419	Color rendering property evaluation R1	-	76	
↓	↓	↓	↓	
↓	Color rendering property evaluation R8	-	98	
↓	Special color rendering property evaluation R9	-	84	
↓	↓	↓	↓	
433	Special color rendering property evaluation R15	-	64	
434	photosynthetic photon flux density PPFD	μ mol/m ² /s	1982.1	To the first decimal place
435	Data end	-	“END”	End command

* 435 items are fixed for output. If the measured value is not normal, “****” is output for the item.



■ SP2, SPR2 command measurement data format

No.	Item	Unit	Example of output	Remarks
1	Measurement range	-	1	
2	Integral time	ms	150	Unit: 1ms
3	Radiant illuminance	W/m ²	2.495E-05	Valid digit of index: 4 digits
4	Illuminance	lx	143.5	Valid digit: Upper 4 digits In the case of 999 or less, the numeral at the first decimal place is indicated.
5	Tristimulus value X	-	144.1	↓
6	Tristimulus value Y	-	143.5	↓
7	Tristimulus value Z	-	83.1	↓
8	Chromaticity x	-	0.3885	To the fourth decimal place
9	Chromaticity y	-	0.3872	↓
10	Chromaticity u'	-	0.2262	↓
11	Chromaticity v'	-	0.5073	↓
12	Correlated color temperature	K	3868	
13	Deviation	-	0.0026	To the fourth decimal place
14	Dominant wavelength	nm	578.3	To the first decimal place
15	Excitation purity	-	0.3281	To the fourth decimal place
16	Peak wavelength	nm	555	
17	photosynthetic photon flux density PPFD	$\mu\text{mol}/\text{m}^2/\text{s}$	1982.1	To the first decimal place
18	Data end	-	"END"	End command

* 18 items are fixed for output. If the measured value is not normal, "****" is output for the item.

4.5. WIRELESS LAN CONNECTION

This chapter will explain how to connect the instrument with the wireless LAN access point (hereinafter, access point).

 NOTICE	<p>The frequency 2.4GHz band, which is used by the instrument, is also used by electronic ovens, medical instruments and other wireless stations.</p> <ol style="list-style-type: none"> 1. When using the instrument, check if any other wireless station or wireless equipment is used in its periphery. 2. If radio wave interference has occurred, change the location of the instrument or stop using the wireless LAN for the instrument. 3. The wireless LAN module, which conforms to the Japanese technical standards, is built in the instrument (IM-1000). Although inside of JAPAN ,and Europe (CE), North America (FCC), and South Korea (KC) which acquired wireless LAN certification can use wireless LAN function, wireless LAN cannot be used in another country and area. 4. If you use this equipment in the country which does not acquire the wireless LAN standard, be sure to turn off the wireless LAN function. <p style="text-align: right;"> "3.2.11. Setting the wireless LAN"</p>
--	---

MEMO

- The explanation in this chapter will be done on the assumption that setting the access point has already been finished.
- For setting and operating the access point, check the instruction manual of the access point.
- The procedure in this chapter is one example. It cannot be applied to some access points.

■ Connection (when the access point has the easy connection AOSS function)

1. Set the IP address, subnet mask and port number of the instrument in the function mode. The IP address must be fit to that on the access point.

* IP ADDRESS *	* SUBNET MASK *	* PORT SELECT *
192.168.100.1	255.255.255.0	50000

2. Turn on the power of the access point and enable it to be connected.
3. Retrieve and set the access point in the function mode. After setting, cancel the function mode.

* PC AP SELECT *	Please Wait...	* PC AP SELECT *
PC_AP PUSH ENTER		* LAN 12345 PC_AP

4. Press the [INV.] switch and then the [WPS] switch to connect with the access point.

- Press the [AOSS] button of the access point until the corresponding LED blinks twice.

<p>Connecting...</p> <p>Please Wait</p>

- When the connection is finished normally, "W" is indicated as the status display.
If the connection has failed several times, check the setting of the instrument and access point.
Then, wait for 3 minutes or more and start the connection again.

FL	SGL	W
r1		
	Ev	100000 lx
	x	0.4474
	y	0.4076

■ Connection (when the access point does not have the easy connection function)

- Set the IP address, subnet mask and port number of the instrument in the function mode. The IP address must be fit to that on the access point.

<p>* IP ADDRESS *</p> <p>192.168.100.1</p>	<p>* SUBNET MASK *</p> <p>255.255.255.0</p>	<p>* PORT SELECT *</p> <p>50000</p>
--	---	-------------------------------------

- Set "WEP" and "PASS PHRASE", which are set for the access point, into the instrument.

<p>* WEP KEY *</p> <p>0123456789</p>	<p>* PASS PHRASE *</p> <p>0123456789</p>
--------------------------------------	--

- Turn on the power of the access point and enable it to be connected.
- Retrieve and set the access point in the function mode. After setting, cancel the function mode.

<p>* PC AP SELECT *</p> <p>PC_AP</p> <p>PUSH ENTER</p>	<p>Please Wait...</p>	<p>* PC AP SELECT *</p> <p>* LAN 12345</p> <p>PC_AP</p>
--	-----------------------	---

5. Press the [INV.] switch and then [W-LAN] switch to connect with the access point.

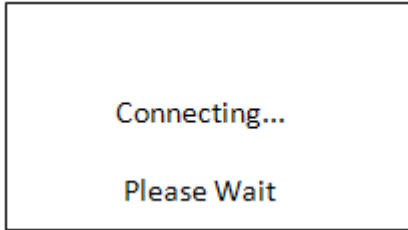

6. When the connection is finished normally, "W" is indicated as the status display.
If the connection has failed several times, check the setting of the instrument and access point.
Then, wait for 3 minutes or more and start the connection again.

FL	SGL	W
r1		
	Ev	100000 lx
	x	0.4474
	y	0.4076

5. ERROR CODE

5.1. ERROR CODE LIST

This chapter will explain the error messages and error codes that will be displayed on the instrument and be obtained by the “ERR” command.

Code	Contents	Remedial measure	Message
0	The instrument is normal.	A remedial measure is not necessary.	
1 13	A system error has occurred.	Contact TOPCON TECHNOHOUSE. When contacting our company, inform us of the error code, the occurrence frequency, the power supply status (AC adapter or batteries) and the occurrence status as detailedly as possible.	system error mode change error
2 3	A trouble has occurred in the internal memory.	It is probable that the internal memory is damaged. Restart the instrument by turning OFF and then ON. Then, contact TOPCON TECHNOHOUSE. When contacting our company, inform us of the error code, the occurrence frequency, the power supply status (AC adapter or batteries), the occurrence status and the condition at restart as detailedly as possible.	memory init error memory access error
5	The correction factor calculation has failed.	Check the following points. - Does an error occur when measurement is performed? - Is the measured value abnormal?	calculation error
6	The parameters are not normal.	Check the following points. - Are the parameters for sending within the allowable setting range? - Is the quantity of the parameters for sending correct?	parameter error
7 9	Initialization of RS-232C has failed. Initialization of the wireless LAN has failed.	It is probable that the internal device is damaged. Restart the instrument by turning OFF and then ON. Then, contact TOPCON TECHNOHOUSE. When contacting our company, inform us of the error code, the occurrence frequency, the power supply status (AC adapter or batteries), the occurrence status and the condition at restart as detailedly as possible.	RS-232C init error LAN init error

Code	Contents	Remedial measure	Message
8 10 32 33 34	A trouble has occurred in the RS-232C communication. A trouble has occurred in the wireless LAN communication.	Check the following points. - Is the communication data (of wireless LAN access point) set correctly in both the external control device and the instrument? - Is the exclusive RS-232C cable connected to both the external control device and the instrument normally? - Is the straight wiring cable used when the RS-232C extension cable is used?	RS-232C trans error LAN trans error over run error flamig error parity error
11 12	Under range error has occurred. Over range error has occurred.	Check the following points. - Is the measured brightness within the allowable measurement range? - Is the measurement range mode set to [AUTO FIRST] or [MANUAL RANGE]? Is measurement performed where brightness is sharply changed? - Does the error occur though the measurement range mode is set to [AUTO FULL]?	under range error over range error
14	The set value is beyond the allowable range.	Set a value within the allowable range.	value out of range
17 18 19 20 21 22	A trouble has occurred in motor or sensor.	It is probable that the motor or sensor is damaged. Restart the instrument by turning OFF and then ON. Then, contact TOPCON TECHNOHOUSE. When contacting our company, inform us of the error code, the occurrence frequency, the power supply status (AC adapter or batteries), the occurrence status and the condition at restart as detailedly as possible.	mtor init error mtor origin error mtor move error mtor sensor error mtor signal error mtor pos error
23	A trouble has occurred in the photo detector or internal PCB.	It is probable that the photo detector or internal PCB is damaged. Restart the instrument by turning OFF and then ON. Then, contact TOPCON TECHNOHOUSE. When contacting our company, inform us of the occurrence frequency, the power supply status (AC adapter or batteries) and the occurrence status as detailedly as possible.	count read error
31	The instrument has exceeded the interval time	Set the longer interval time than the measurement time.	interval time over

35	Power is not sufficient.	Replace the batteries immediately.	LOW BATTERY
----	--------------------------	------------------------------------	-------------

Measurement range mode	AUTO MANUAL	AUTO FULL / AUTO FIRST / AUTO ADJUST MANUAL RANGE
Display mode	[Ev/x/y] [Ev/u'v'] [X/Y/Z] [Ev/Tcp/duv] [Ev/Ra/Tcp] [Ev/ λ d/Pe] [Spectral radiation illuminance graph] [PPFD]	Illuminance Ev / Chromaticity x / Chromaticity y Illuminance Ev / Chromaticity u' / Chromaticity v' Tristimulus values X/Y/Z Illuminance Ev / Correlated color temperature Tcp / Deviation duv Illuminance Ev / Average color rendering property evaluation Ra / Correlated color temperature Tcp Illuminance Ev / Dominant wavelength λ d / Excitation purity Pe Photosynthetic photon flux density PPFD
Warm-up time		When the measured illuminance is less than 20 lx: 10 minutes or more *When the measured illuminance is 20 lx or more, warm-up is not necessary.
Measurement time		Approx. 0.2 seconds (When the measurement range is "MANUAL", 100ms is fixed as the integral time and the "STR2" command is used) * The measurement time is sometimes longer due to the personal computer specification, the use environment and the command receiving timing.
Display		Approx. 0.5 - 50 seconds (Measurement range: AUTO) Liquid crystal display unit with 128×64 dots and back light ON/OFF function
Interface		RS-232C (The values are fixed except the baud rate.) - Communication method Full duplex - Synchronization Start-stop transmission - Baud rate 9600/19200/38400 bps (Bits Per second) - Data length 7 bits - Parity Odd number (ODD) - Stop bit 1 bit - Communication type Text (ASCII) - Delimiter CR + LF Wireless LAN (exclusively for Japan) - Standard to be observed IEEE802.11b infrastructure/ad hoc mode - Frequency range 2.4GHz band (1-13ch) - Communication distance Indoors 10m/Outdoors 15m typ - Baud rate 38400 bps - Security WEP/WPA/WPA2

Power supply	Nickel hydride AA battery: 4 pcs. (Standard accessory) *Battery life (Operable time): Approx. 7 hours (When the new nickel hydride batteries (standard accessory) are fully charged) Exclusive AC adapter (optional accessory)
Operating conditions	Temperature -10°C - +40°C Humidity 85%RH or less (without dew condensation)
Storing conditions	Temperature -10°C - +50°C Humidity 85%RH or less (without dew condensation)
External dimensions	Approx. 70 (width) × 250 (depth) × 78 (height) mm (Without detector window cap and power switch)
Weight	Approx. 640g (including the batteries)
Measurement reference surface	Edge of detector window

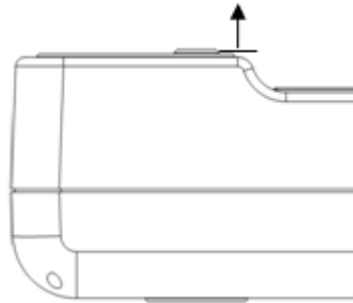

BLOCK DIAGRAM

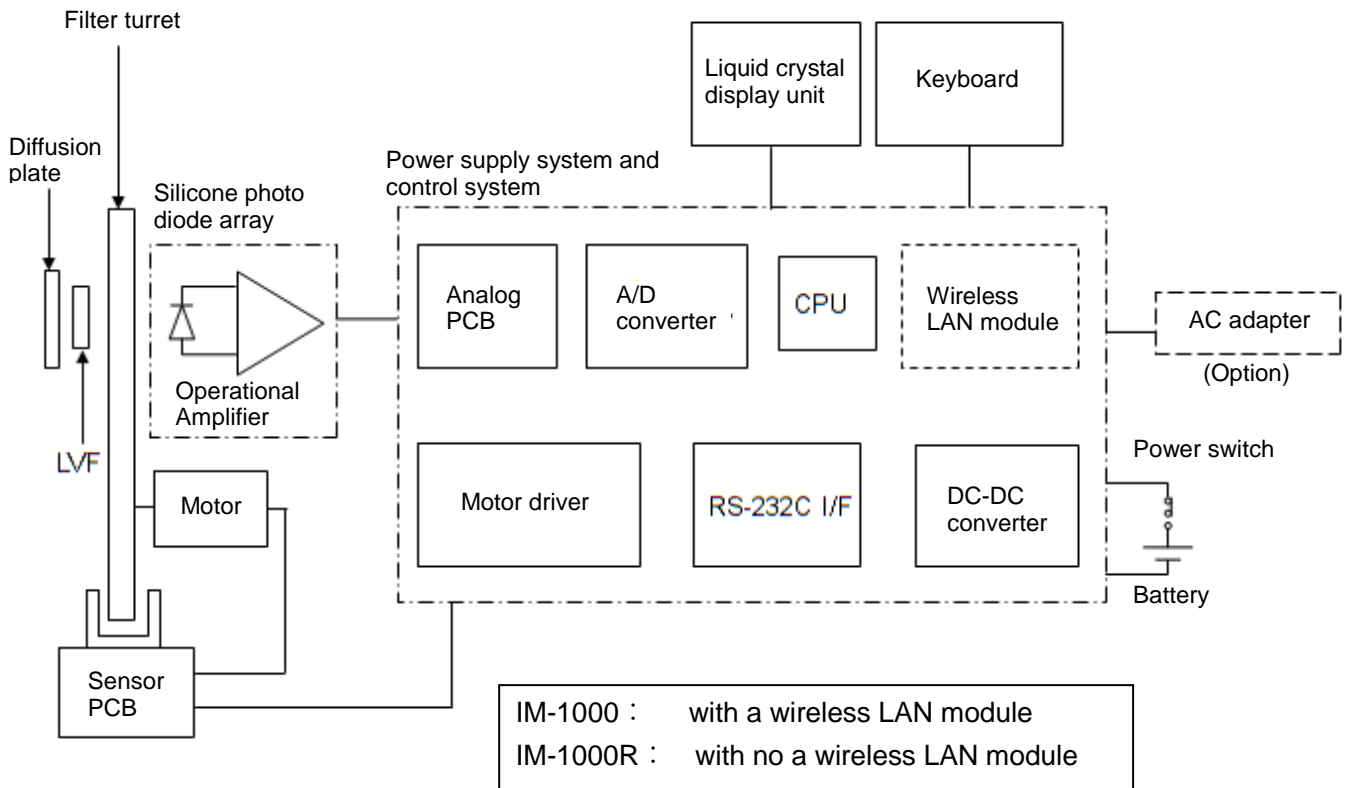

EXTERNAL DIMENSIONS DIAGRAM

 **Request** Use only specified screws when using the tripod screw and screw holes for jig attachment. Do not tighten the screws any more than necessary. Doing so might cause internal breakage.

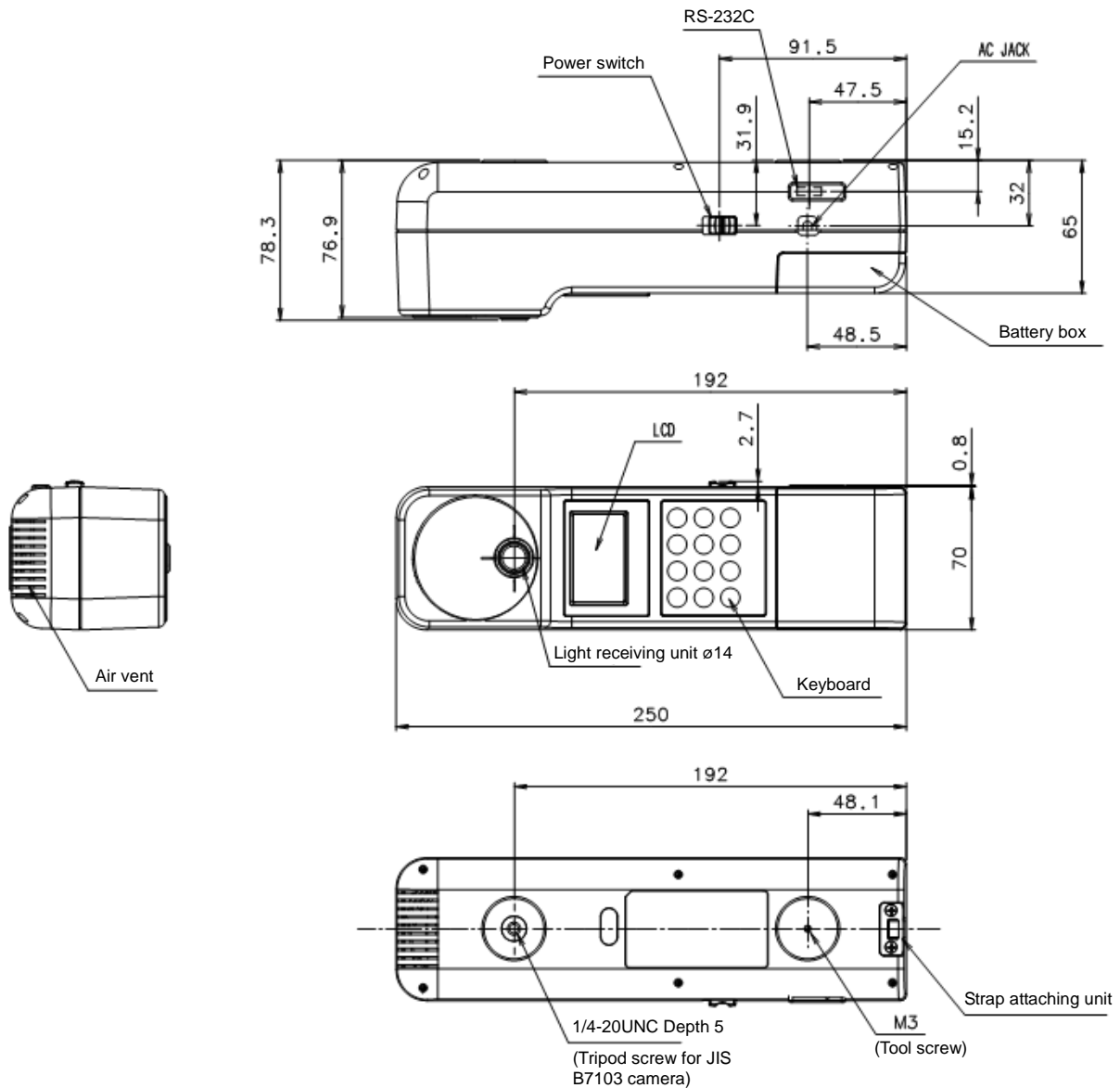

GRAPH

Deviation from spectral luminous efficacy (Typical value)

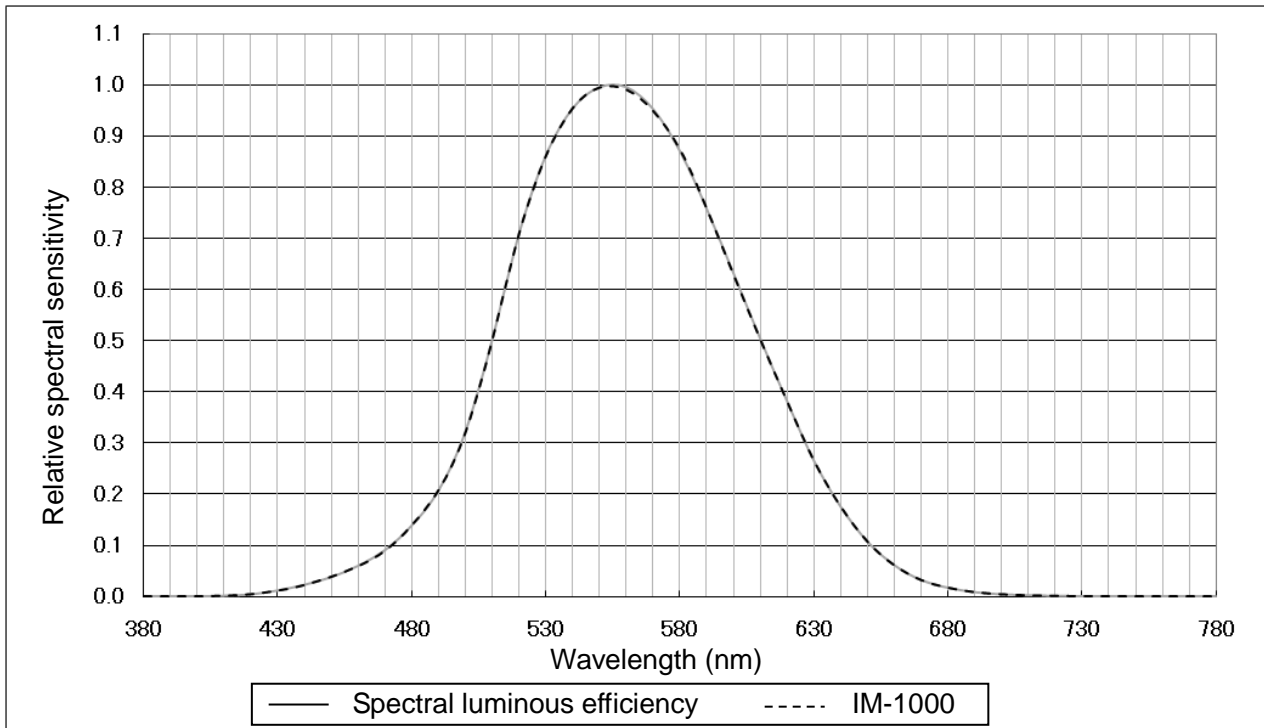

INFORMATION ABOUT OVERSEAS REGULATION

■ IM-1000 に対して / For IM-1000 / IM-1000 에 대한 기재사항

FCC Compliance Information

This device complies with Part 15 of FCC Rules. Operation is subject to the following two conditions:

- (1) the device may not cause interference, and
- (2) the device must accept any interference, including interference that may cause undesired operation of this device.

This equipment has been tested and found to comply with the limits for a Class A digital device, pursuant to part 15 of the FCC Rules.

These limits are designed to provide reasonable protection against harmful interference when the equipment is operated in commercial environment. This equipment generates, uses, and can radiate radio frequency energy and if not installed and used in accordance with the instruction manual, may cause harmful interference to radio communications. Operation of this equipment in a residential area is likely to cause harmful interference in which case the user will be required to correct the interference at his own expense.

IMPORTANT NOTE:

FCC RF Radiation Exposure Statement:

This equipment complies with FCC RF radiation limits set forth for an uncontrolled environment. This equipment should be installed and operated with a minimum distance of 20 centimeters between the radiator and your body. This transmitter must not be co-located or operating in conjunction with any other antenna or transmitter.

■ IM-1000R に対して / For IM-1000R / IM-1000R 에 대한 기재사항

FCC Compliance Information

This device complies with Part 15 of FCC Rules. Operation is subject to the following two conditions:

- (1) the device may not cause interference, and
- (2) the device must accept any interference, including interference that may cause undesired operation of this device.

This equipment has been tested and found to comply with the limits for a Class A digital device, pursuant to part 15 of the FCC Rules.

These limits are designed to provide reasonable protection against harmful interference when the equipment is operated in commercial environment. This equipment generates, uses, and can radiate radio frequency energy and if not installed and used in accordance with the instruction manual, may cause harmful interference to radio communications. Operation of this equipment in a residential area is likely to cause harmful interference in which case the user will be required to correct the interference at his own expense.

■ KC Information:

Republic of Korea	KC:Class A	해당 무선설비는 전파혼신 가능성이 있으므로 인명안전과 관련된 서비스는 할 수 없습니다 A급 기기 (업무용 방송통신기자재) 이 기기는 업무용(A급) 전자파적합기기로서 판매자 또는 사용자는 이 점을 주의하시기 바라며, 가정외의 지역에서 사용하는 것을 목적으로 합니다
-------------------	------------	--



EU Battery Directive

This symbol is applicable to EU members states only.

Battery users must not dispose of batteries as unsorted general waste, but treat properly. If a chemical symbol is printed beneath the symbol shown above, this chemical symbol means that the battery or accumulator contains a heavy metal at a certain concentration. This will be indicated as follows:
Hg: mercury(0.0005%), Cd: cadmium(0.002%), Pb: lead(0.004%)

These ingredients may be seriously hazardous to human and the global environment.

Warranty Period

One year from the date of shipment from TOPCON TECHNOHOUSE.

Repair During Warranty Period

If trouble should arise during normal use of the IM-1000, we will make repairs resulting from design or manufacturing defects at no charge.

Repair After Warranty Period

If functionality can be restored through repair, we will repair your instrument for a charge.

Maintenance Period

The repair parts (*1) are retained by us for eight years (*2) after purchase.

We will repair the IM-1000 while these parts remain in stock.

After the stocking period, we may be able to repair the IM-1000. Consult with your retailer or TOPCON TECHNOHOUSE for further details.

(*1) Functional repair parts are those parts required to make the IM-1000 function.

(*2) Although we strive to meet this stocking period, it may be shortened due to unforeseen circumstances.

Disposal

Follow local disposal and recycling ordinances when disposing of the IM-1000.

Please have the following information available when making an inquiry:

- Serial number: Noted on the specification plate on the bottom of the instrument.
- Use period: The dates of purchase as well as the last calibration.
- Environment: Type of measurement light source, instrument settings, measurement values, measurement status, etc.
- Description of problem: As detailed as possible.

Inquiries: Refer to the back cover of this manual for contact information.

ILLUMINANCE SPECTROMETER

IM-1000 ***IM-1000R***

Contact information:

TOPCON TECHNOHOUSE CORPORATION

75-1 Hasunuma-cho, Itabashi-ku, Tokyo 174-8580 Japan

◆ Inquiries regarding the product

Sales Department Tel +813(3558) 2666 Fax +813 (3558) 4661

◆ Inquiries regarding repairs and maintenance

Service Department Tel +813 (3558) 2710 Fax +813 (3558) 3011

Illuminance spectrometer IM-1000

Instruction Manual

2016 Edition

Date of issue First edition : July., 2012

11th edition : Sep., 2018

Published by: Topcon Technohouse Corporation

©2012 TOPCON TECHNOHOUSE CORPORATION
ALL RIGHTS RESERVED

Unauthorized copying prohibited.