

**5 million pixels (2448x2048) with 5 million points spectral data.  
High luminance 17 billion cd/m<sup>2</sup> with built-in ND filter.**

**2D Spectroradiometer *SR-5100***

**2D spectroradiometer contributes to maintaining high quality of various products as it can evaluate the spectral characteristics of light sources or objects with 5 million pixels.**

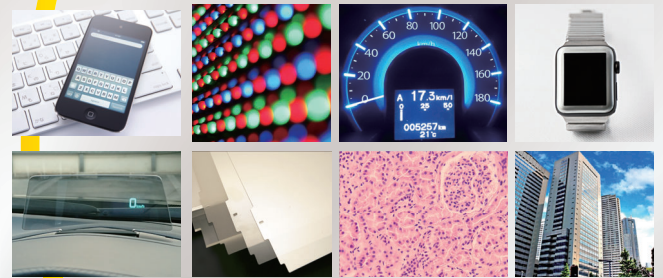

# Here is the ultimate solution that spectroscopic and colorimetry via 2D spectroradiometer.



**By Non-Destruction and Non-Contact, 2D spectroradiometer instrument that contributes to maintaining high quality of various products as it can evaluate the spectral characteristics of light sources or objects with 5 million pixels.**



**Replacing the measured numerical data with pseudo-color, grayscale, and RGB images, it enable to display Mura of the object.**



**By measuring spectrum and analyzing the specrum of the object, it can evaluate sample for not only characteristics that are difficult to detect with the human eye or filter-typed imaging luminancemeter, but also refracted light of objects and lighting simulations.**

- High resolution 5 million pixels (2448×2048) spectral measurement and high luminance (17 billion cd/m<sup>2</sup>) .
- Non-destructive and non-contact, 5 million points of spectral evaluation for the characteristics of light sources, spectral transmittance characteristics of materials, and spectral reflectance characteristics with high accurate 1nm pitch measurement.
- Microscope system enables to evaluate spectral data for small area with um pixel level. (micro spectroscopy)
- Imaging spectroradiometer with the same performance as a spot type spectroradiometer.
- High luminance and chromaticity accuracy is guaranteed by calibration using a light source with traceability.
- High-precision and high-speed convertible model that takes advantage of 2way measurement methods of spectral and XYZ filters.
- Application software and SDK included as standard.
- Measurement function : Luminance, Chromaticity(x,y, u'v'), Correlated color temepereture, Dominant wavelength, Excitation purity, Peak wavelength, Irradiange, Spectral radiance, L\*a\*b\*, Hue-Chroma, RGB

## Spectral mode

**1** *Spectral measuing of each 1 nm*  
Measurement wavelength select from 1nm, 5nm and 10nm pitch.

**2** *High accuracy measurement by spectrophotometry method*  
Measurement example at 200 cd/m<sup>2</sup>  
Luminance : -0.08%, Chromaticity : 0.0001  
\*Standard illuminant A, Center of the censor, Average at 10 units

**3** *Measurement of lower luminance from 0.5 cd/m<sup>2</sup>.*  
Measure 0.5 cd/m<sup>2</sup> to 17 billion cd/m<sup>2</sup> and luminance, chromaticity and spectrum accurately.

**4** *Measurement of designated range.*  
Measurement time will be faster when setting designated measurement area or wavelength range.

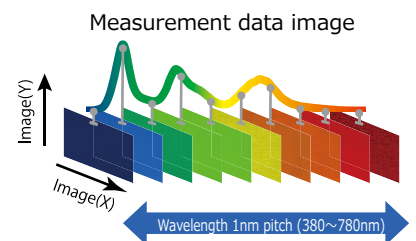

## XYZ(Filter) mode

**1** *High accuracy measurement up to 0.005 cd/m<sup>2</sup> that is in ultra-low luminance range.*  
Measure luminance and chromaticity from 0.005 to 100,000 cd/m<sup>2</sup> with high accuracy by using our own optical XYZ filter.  
\*Standard illuminant A.

**2** *High speed measurement.*  
Measurement for luminance and chromaticity is possible in approx.12 sec when luminance of light source is 200 cd/m<sup>2</sup>.

## Common function

**1** *5 Mega pixel CMOSsensor.*  
Measurement of 2448 × 2048 pixels.

**2** *Synchronous measurement.*  
Measure stably by inputting the synchronization signal when measuring the blinking light source such as OLED.

**3** *Frequency measurement.*  
Measure stably by setting frequency when measuring the pulse emitting light source. \*4 to 20,000 Hz

**4** *Layer function.*  
It is most suitable for light-shade measurement of the object that have wide dynamic range.

**5** *Evaluation for the automotive display*  
Using by optional software Black MURA, it is suitable for the evaluation of automotive diplay standard in EU.

**6** *External control efficiency.*  
In addition to our standard SDK, Saving as the HDF5 format read by MATLAB®.

# Colorimetric Image Software **CI-100**



You can control the SR-5100 series and retrieve measured data, save data, convert measured data into image via PC.

The application software conducts various types of data processing and data analyzing efficiently.

Two types mode are available for your usage.

**•Measurement mode**

Full functions are available including SR-5100 series control.

**•Review mode**

Viewer software for viewing image data and analyzing measured data, and can analyze measured data at other place without the instruments.

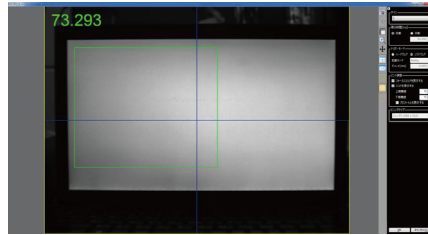

**•Live view**

Real time image that is automatically adjusted by brightness show on PC. You can check measurement area of target and adjust the position via Live-view image.

**•Focusing assist**

This function is used to adjust focus at real time. The ratio of focusing is displayed, and you can adjust stable focusing.

**•Optimizing area**

Measuring condition is optimized at specified area by specifying area even if there are some light in out of measurement area.

**•Scale display**

Pixel number of specified area and length equivalent to pixel number(mm) is shown.

**•Zoom/Move**

You can zoom and move the position anywhere in the live image.

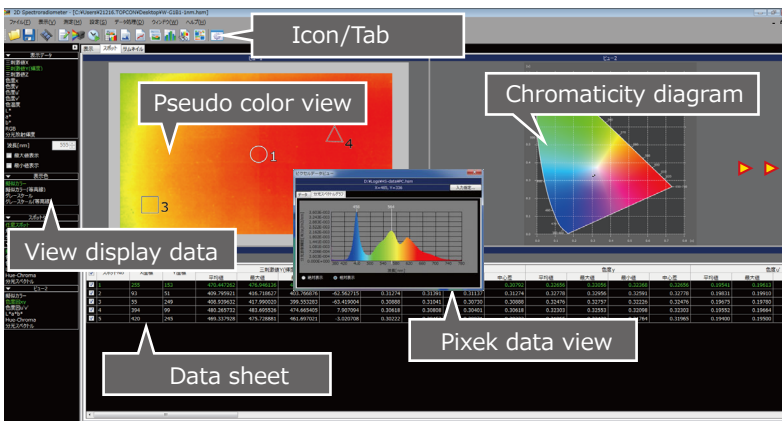

**Measured data can paste to spreadsheet software.**

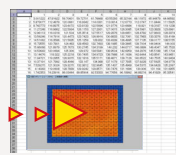

Measured data in each view can save as CSV, txt, or image file (BMP/JPG/PNG), and can paste to spreadsheet software such as Excel.

**Selectable data item in view window.**

- |                                 |                               |
|---------------------------------|-------------------------------|
| 1. Tristimulus values (X, Y, Z) | 4. Colorimetric system L*a*b* |
| 2. Chromaticity x, y            | 5. R,G,B                      |
| 3. Chromaticity u', v'          | 6. Spectral radiance          |

## Main view window

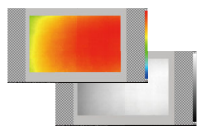

**1. Pseudo color / Gray scale**  
Software-colored image and 16,384 steps gray scale present the difference in luminance / chromaticity on measuring area. This view is suitable for uniformity measuring.

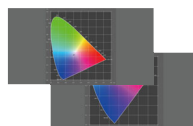

**7. x, y, u', v' Chromaticity diagram view**  
Chromaticity value on the spot can plot on the x, y or u', v' diagram. The plotted diagram can scale up.

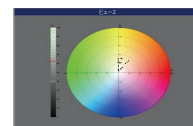

**13. L\*a\*b\***  
Chromaticity L\*a\*b\* of each spot is plotted on the chromaticity diagram, and the color distribution can confirm. Also, chromaticity diagram is possible to zoom up for checking where plotted points concentrated.

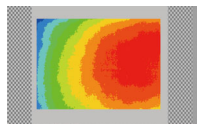

**2. Contour view**  
This view use contour lines to indicate the profile of each tristimulus value.



**8. Histogram View**  
The statistical graphics indicates the number of pixel in the vertical axis and the tristimulus value or chromaticity in the horizontal axis.



**14. Spectral radiance image**  
Measured data is displayed as an image for each wavelength.



**3. Split spot view**  
The image divided with grid pattern shows the average value in the each divided area is calculated.

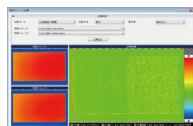

**9. Measured images comparison**  
Differences of measured each images and differences by ratio calculation are displayed as images. By entering mathematical expressions, you can freely define the comparison method.

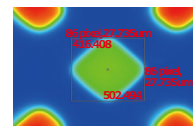

**15. Ruler & Ruler correction**  
The numerical value (pixel number or th "mm" size equivalent to the pixel number), which are displayed by dragging the mouse left button. Ruler correction can set the difference with real size.

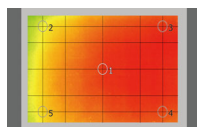

**4. Standard spot view**  
Four type of Measuring standard available such as JEITA standard (EIAJ ED-2522/ ED-2710). You can customize the measuring spot size and the number of measuring spot.



**10. Spot comparison**  
Differences of measured each images and differences by ratio calculation are displayed as images.



**16. Auto spot**  
Create the grid pattern spots automatically by parameters. Measured data is displayed as an image for each wavelength.

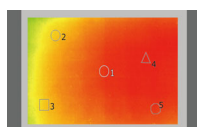

**5. Random spot view**  
Max 999 measuring spots can place on an image. Shape of measuring spots can select from Circle, Rectangle, Polygon (max 127 vertex).

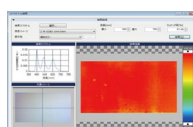

**11. Spectral search**  
The matching ratio of each spectral is displayed.



**17. Auto Time-series graph view**  
The horizontal axis represents time passage and vertical axis represents the time-series analysis results as a graph. Data sheet display the measured value of each spot in the chronological order on the spreadsheet.

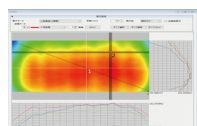

**6. Cross section view**  
Tristimulus value on the cross-section line is expressed as graph. The cross-section line are selectable from cross line or diagonal line (max.10 lines). Line width expand.

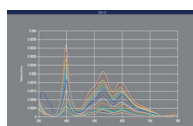

**12. Spectrum**  
Spectral radiance for each wavelength of the measurement spot is displayed. The horizontal axis represents wavelength and the vertical axis represents spectral radiance.

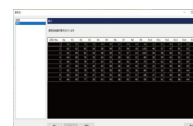

**18. Color rendering index**  
Color rendering index displays for each spot in the measured image of the property of the light source (how the color looks compared to the standard illuminant).  
• General color index (Ra)  
• Special color index (R9-R15)

## Lineup and usage

### SR-5100HWS

Standard lens



Wide lens



- Large and middle size display panel
- Evaluation of luminance / chromaticity mura and spectral of the light emitting part of LED lighting and OLED lighting
- Evaluation of optical characteristic of digital signage and outdoor advertising panel.
- Measurement of film and glass coating mura and interference fringes
- Analysis and quantification evaluation of slight differences in the staining
- Skin care assessment of skin blemishes and pigmentation
- Analysis of absorption, reflection and transmission characteristics
- Spectral evaluation of all objects in the landscape indoors and outdoors

### SR-5100HT

Telephoto lens



- Middle and small size display panel
- Emission distribution characteristics and spectral evaluation of automobile meter panels and interior / exterior lighting
- Evaluation of luminance / chromaticity mura and spectral of the AR/VR panel
- Evaluation of luminance / chromaticity mura and spectral of the smart watch and wearable devices panel

### SR-5100HM

Macro lens

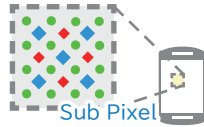

- Evaluation of light emitting surface of various size with using C-mount adapter and various lenses
- Evaluation of very small lighting area by combing C-mount adapter and microscope
- Cell spectral analyzation of biotissue
- subpixel evaluation of LCDs, OLEDs, QDs, lasers, micro LEDs and related components and materials
- Evaluation of the AR,VR, MR devices

## Usage examples

### Evaluation of luminance, chromaticity and spectrum unevenness for OLED, LCD, $\mu$ /mini LED and related materials.

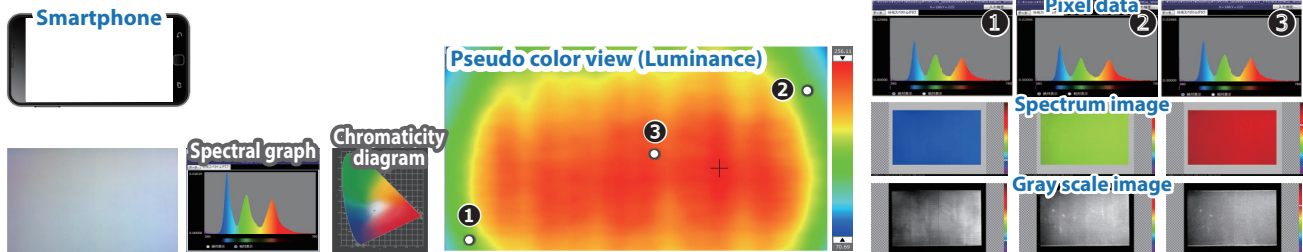

“Color shift” occurs due to low durability of OLED’s RGB organic matter, and it is detected by shift of spectrum, luminance and chromaticity.

### Evaluation for automotive interior and exterior lamp.

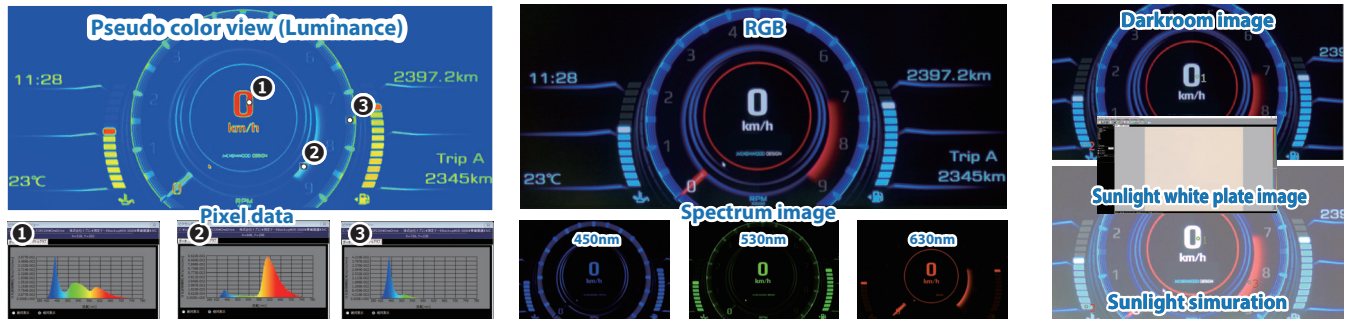

Evaluation for luminance unevenness, spectrum of specified points, luminance or chromaticity of object such as indicator.

Sunlight simulation

### Skin care assessment

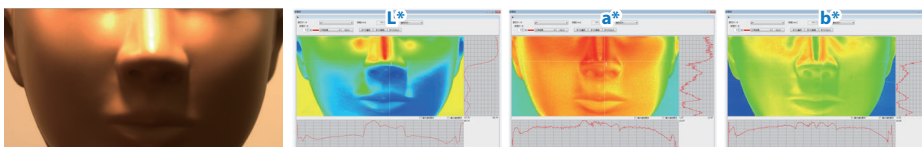

### Evaluation for automotive interior

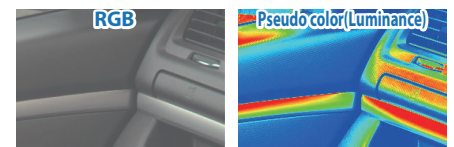

## Multi points color rendering index

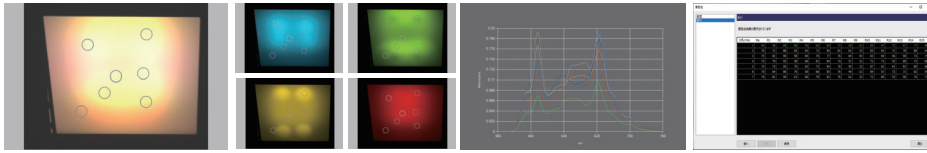

## Mini-LED evaluation

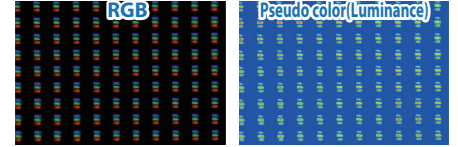

## Color chart evaluation

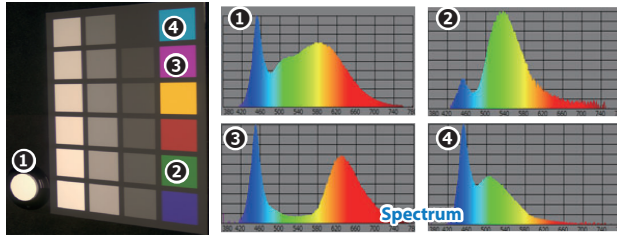

## Environmental measurement

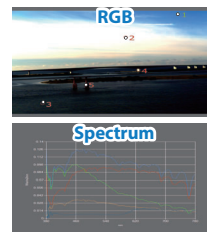

## Spectral search

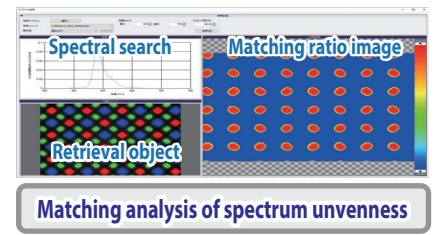

## SR-5100HM C-mount adapter application example

Enable to evaluate high accurate spectrum distribution with contactless by microscope lens, zoom lens and system integration.

### AR, VR, MR devices evaluation



Wide angle

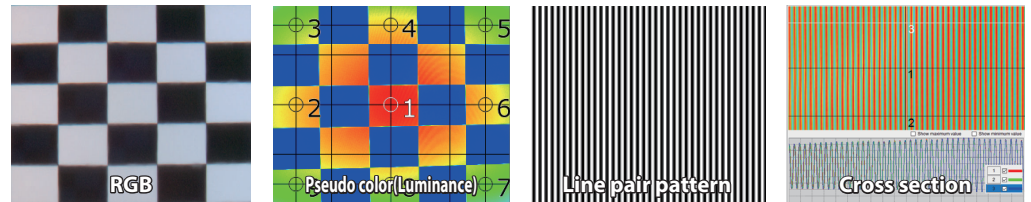

Wide field evaluation of AR,VR,MR devices using wide angle lens

SR-5100HM + Wide angle lens

Eye point (mm)	Horizontal x Vertical x Diagonal(°)	Entrance Pupil Diameter(mm)
7.3	117.7 x 86.7 x 146.2	2.5
13.4	34.6 x 25.9 x 43.2	8.6
14.5	82.4 x 66.9 x 106.1	1.8

### ZOOM lens



Large area measurement

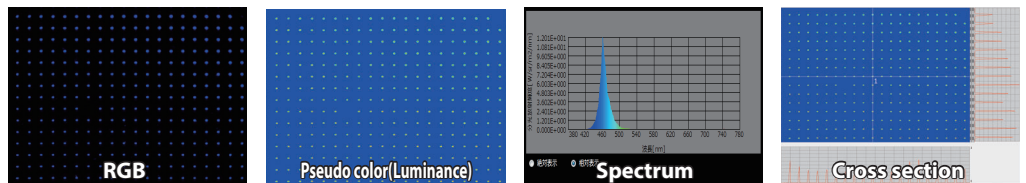

Expanding of FOV for Higher Throughput w/accurate Luminance, Chromaticity and Wavelength Peak.

SR-5100HM+Zoom lens

	1x Zoom	0.5x Zoom	0.3x Zoom
Measurement area [mm]	6.8x5.7	13.5x11.3	22.53x18.83
Resolution [ $\mu\text{m}/\text{pixel}$ ]	3.45	6.9	11.51

### Microscope



Micro-spectral measurement

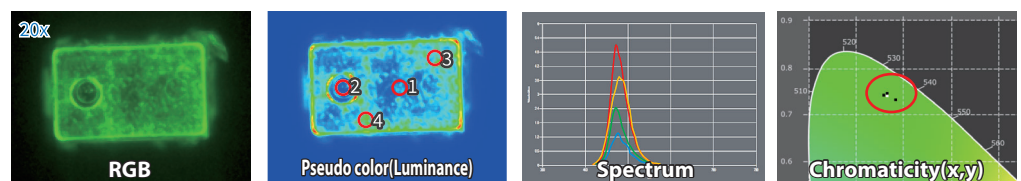

Evaluate of very small lighting area about Micro or Mini LED by combining with microscope.

SR-5100HM+Microscope(Objective lens)

	5x	10x	20x
Measurement area [mm]	1.35x1.13	0.68x0.57	0.338x0.283
Resolution [ $\mu\text{m}/\text{pixel}$ ]	0.69	0.35	0.17

High magnification for observation

	50x	100x
Measurement area [mm]	0.135x0.113	0.068x0.057
Resolution [ $\mu\text{m}/\text{pixel}$ ]	0.069	0.035

## Optional accessories



### ● Tripod 5N

Easy collimation of measurement object.

- Max height: 1835 mm
- Min height: 585 mm
- Folder length: 810 mm
- Leg section: 3 steps
- Weight: Approx. 4.8kg including Tripod head

### ● SR-5100HM optional accessories



### ● ZV-60 MS-ADAPTER

It is the adapter for connecting the microscope and C-mount port.



### ● ZV-57 / ZV-58 MS-CORRECT

Spectral transmission factor correction tool for microscope lens.

- Light source : Halogen lamp
- Lamp life : Approx. 700 hours
- Operating conditions : Temperature 0 to 40°C Humidity 20 to 80%R.H. (No condensation)
- Dimensions : Light unit : 115x130x281 mm  
Diffuser unit : 109x29x62 mm  
Light guide length : 1 m
- Power supply : ZV-57(AC 100 to 120V)  
ZV-58(AC 200 to 220V)

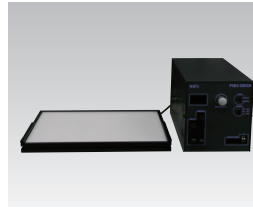

### ● ZV-61 LENS-CORRECT

Spectral transmission factor correction tool for zoom lens.

- Operating conditions : Temperature 0 to 40°C Humidity 20 to 80%R.H. (No condensation)
- Dimensions : Light unit : 97x245x110 mm  
Diffuser unit : 223x212x19mm  
Light guide length : 2 m
- Power supply : AC 100 to 240V

## SDK (Software Development Kit)

Development kit is composed of header file and library to control SR-5100 through a network PC.

It is possible to create customized software according to external communication and the needs of user.

It can acquire and display only the necessary data, and it is also possible to reduce the file size of measurement data.

Sample program is also included.

## Optional software

# Black MURA



BlackMURA provides display quality analysis to DFF's vehicle OEM workgroup BlackMURA standards.

### Evaluation function

- Uniformity/gradient characteristics evaluation
- Luminance homogeneity
- Absolute and relative gradient value
- Luminance contrast and luminance homogeneity contrast
- Report function
- CSV/Image, measurement data automatic output

### Camera profile evaluation

- Center and four corners comparison
- Calculation of resolution
- Calculation of focus

### Center and four corners comparison



### Calculation of focus

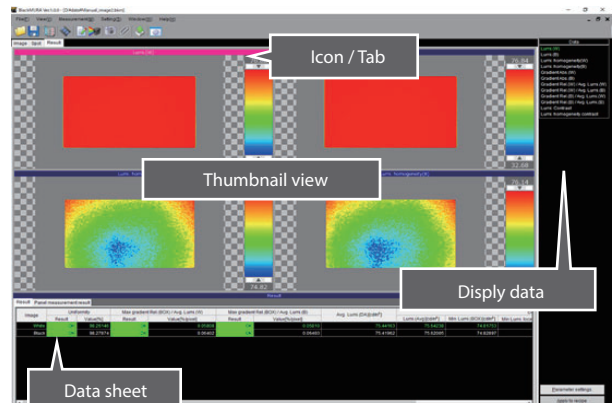

# System diagram

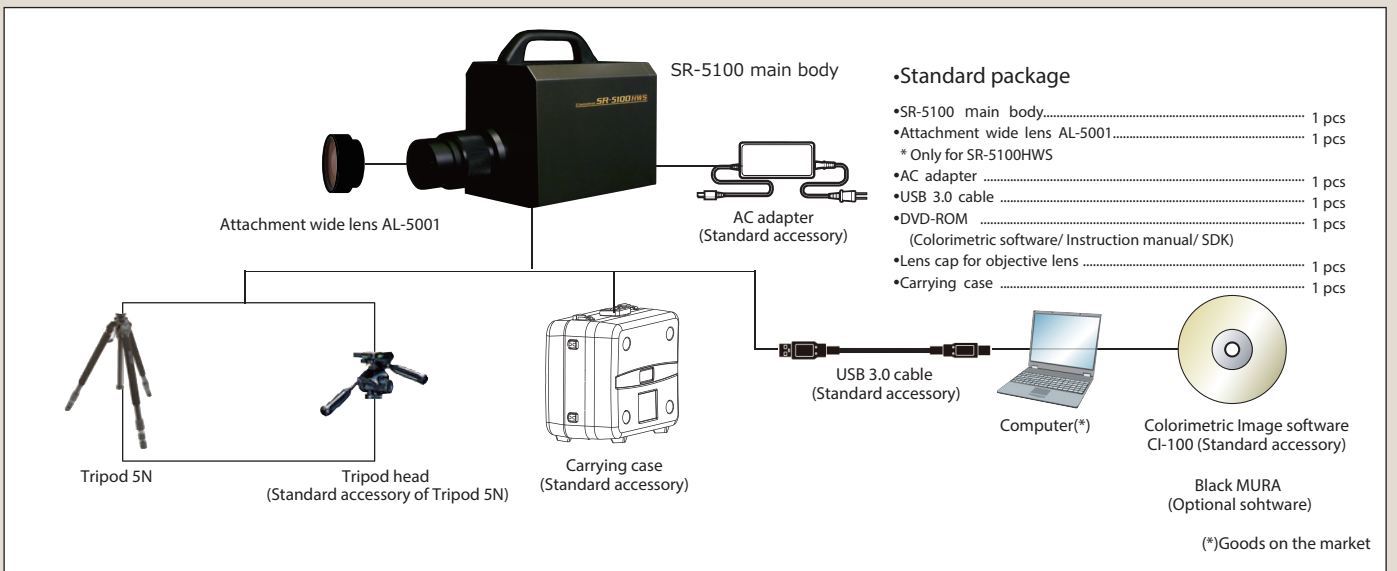

# Dimension

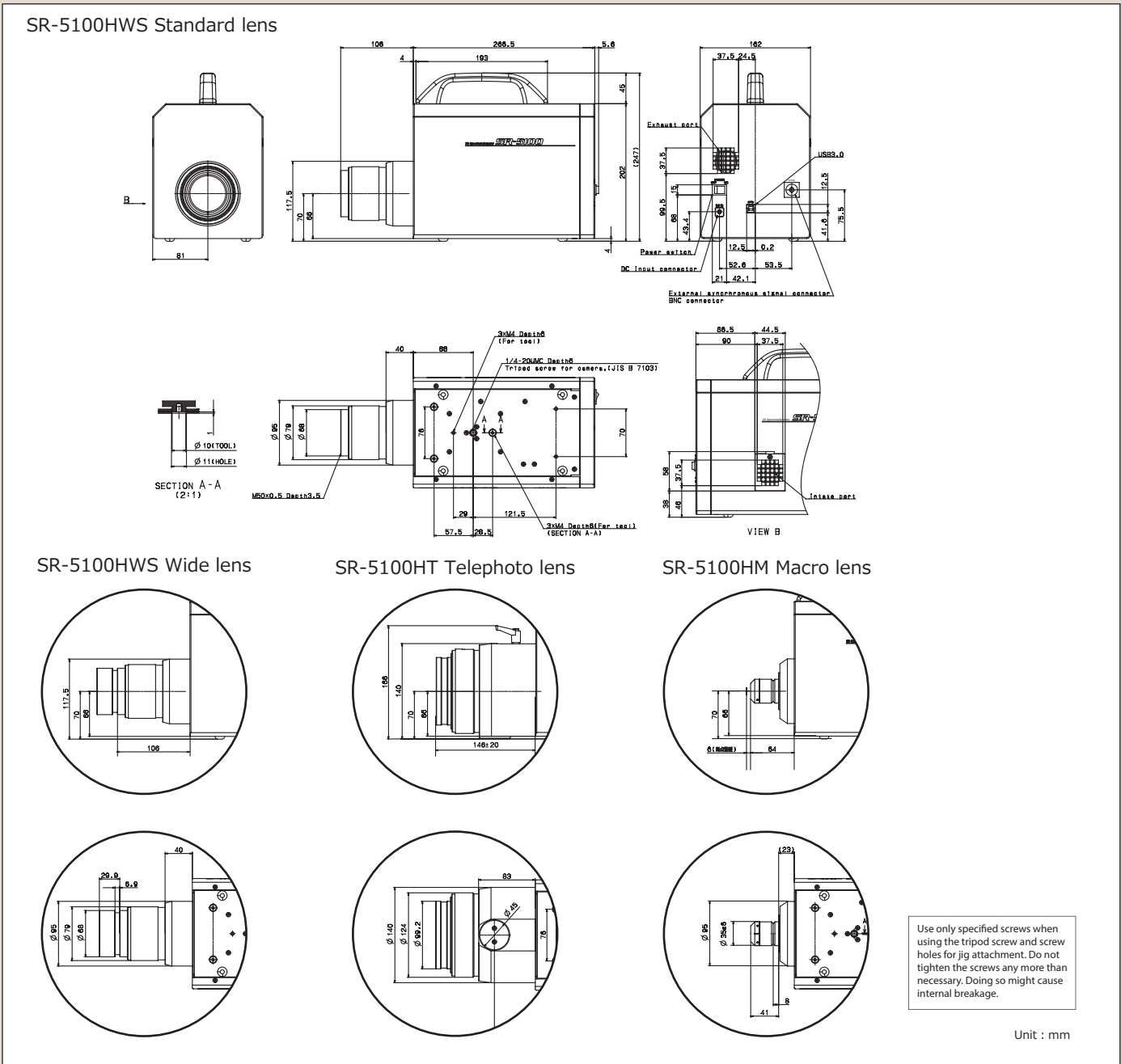

# Specification

		SR-5100HWS		SR-5100HT		SR-5100HM	
Measurement mode		Spectral Mode	XYZ(Filter) Mode	Spectral Mode	XYZ(Filter) Mode	Spectral Mode	XYZ(Filter) Mode
Detector	5 mega pixel CMOS image sensor						
Objective lens		Standard lens / Wide lens *1		Telephoto lens		Macro lens	
	Focal length	f=32mm / f=24mm		f=140mm		-	
Effective pixel	2448x2048						
Measurement range	*2	0.5 - 17,000,000,000cd/m <sup>2</sup>	0.005 - 100,000cd/m <sup>2</sup>	0.5 - 17,000,000,000cd/m <sup>2</sup>	0.005 - 100,000cd/m <sup>2</sup>	0.5 - 17,000,000,000cd/m <sup>2</sup>	0.005 - 100,000cd/m <sup>2</sup>
Wavelength range	*3	380~780nm	-	380~780nm	-	380~780nm	-
Spectral accuracy	*4	±0.5nm	-	±0.5nm	-	±0.5nm	-
Spectral bandwidth	*5	7nm	-	7nm	-	7nm	-
Wavelength resolution		1nm	-	1nm	-	1nm	-
Linearity	Luminance *3,*6	±2%	±3.5% (≤0.01cd/m <sup>2</sup> ) ±3% (0.01cd/m <sup>2</sup> <)	±2%	±3.5% (≤0.01cd/m <sup>2</sup> ) ±3% (0.01cd/m <sup>2</sup> <)	±2%	±3.5% (≤0.01cd/m <sup>2</sup> ) ±3% (0.01cd/m <sup>2</sup> <)
	Chromaticity *3,*6	±0.0035 (≤1cd/m <sup>2</sup> ) ±0.0025 (1cd/m <sup>2</sup> <)	±0.0085 (≤0.01cd/m <sup>2</sup> ) ±0.0050 (≤0.05cd/m <sup>2</sup> ) ±0.0030 (0.05cd/m <sup>2</sup> <)	±0.0035 (≤1cd/m <sup>2</sup> ) ±0.0030 (1cd/m <sup>2</sup> <)	±0.0090 (≤0.01cd/m <sup>2</sup> ) ±0.0050 (≤0.05cd/m <sup>2</sup> ) ±0.0030 (0.05cd/m <sup>2</sup> <)	±0.0035 (≤1cd/m <sup>2</sup> ) ±0.0025 (1cd/m <sup>2</sup> <)	±0.0085 (≤0.01cd/m <sup>2</sup> ) ±0.0050 (≤0.05cd/m <sup>2</sup> ) ±0.0030 (0.05cd/m <sup>2</sup> <)
In-plane uniformity	*9	Luminance: ±2% / Chromaticity: ±0.003					
Repeatability	*3,*6,*7	0.6% (≤1cd/m <sup>2</sup> ) 0.5% (1cd/m <sup>2</sup> <)	0.70% (≤0.01cd/m <sup>2</sup> ) 0.35% (0.01cd/m <sup>2</sup> <)	0.8% (≤1cd/m <sup>2</sup> ) 0.5% (1cd/m <sup>2</sup> <)	0.90% (≤0.01cd/m <sup>2</sup> ) 0.35% (0.01cd/m <sup>2</sup> <)	0.6% (≤1cd/m <sup>2</sup> ) 0.5% (1cd/m <sup>2</sup> <)	0.70% (≤0.01cd/m <sup>2</sup> ) 0.35% (0.01cd/m <sup>2</sup> <)
	*3,*6,*8	0.003 (≤1cd/m <sup>2</sup> ) 0.002 (1cd/m <sup>2</sup> <)	0.006 (≤0.01cd/m <sup>2</sup> ) 0.004 (≤0.05cd/m <sup>2</sup> <) 0.002 (0.05cd/m <sup>2</sup> <)	0.004 (≤1cd/m <sup>2</sup> ) 0.003 (1cd/m <sup>2</sup> <)	0.009 (≤0.01cd/m <sup>2</sup> ) 0.004 (≤0.05cd/m <sup>2</sup> <) 0.002 (0.05cd/m <sup>2</sup> <)	0.003 (≤1cd/m <sup>2</sup> ) 0.002 (1cd/m <sup>2</sup> <)	0.006 (≤0.01cd/m <sup>2</sup> ) 0.004 (≤0.05cd/m <sup>2</sup> <) 0.002 (0.05cd/m <sup>2</sup> <)
Interface	USB3.0 / External trigger						
Power supply	AC100 - 240V (50/60Hz) Dedicated AC adapter						
Power consumption	Approx. 20W						
Operation condition	Temperature: 0 to 35°C, Humidity: 80%R.H. or less (No condensation)						
External dimension	W162xH247xD402.4mm *1			W162xH247xD412.5mm		W162xH247xD330.5mm	
Weight	Approx.6.3Kg			Approx.8.2kg		Approx.5.8kg	

\*1:Standard lens + Attachment lens, \*2:Standard illuminant A, \*3:Standard illuminant A, \*4:Hg, Hi precision mode, \*5:FWHM, Hi precision mode, \*6:At the center of sensor, \*7 Within 2σ, \*8:Max value - Min value, \*9:Center of the sensor, Standard illuminant A, within 80% of field of view,

## Measurement area: Standard lens

Measurement distance (mm)	400	500	1,000	1,500	2,000	2,500
Horizontal (mm)	178.0	221.5	435.9	649.7	866.2	1072.5
Vertical (mm)	148.9	185.3	364.7	543.5	724.7	897.2

## Measurement area: Wide lens

Measurement distance (mm)	400	500	1,000	1,500	2,000	2,500
Horizontal (mm)	246.6	303.0	587.5	869.9	1155.0	1437.5
Vertical (mm)	206.3	253.5	491.5	727.8	966.2	1202.7

## Measurement area: Telephoto lens

Measurement distance (mm)	600	1,000	1,500	2,000	2,500
Horizontal (mm)	60.5	108.6	168.9	229.0	288.7
Vertical (mm)	50.6	90.9	141.3	191.6	241.6

## Measurement area: Macro lens

Measurement distance (mm)	6
Horizontal (mm)	6.8
Vertical (mm)	5.7

\*Above values are design specifications. Above values may be difference from the values in practice.  
\*The measurement distance is from tip of objective lens to the measurement target.  
\*Above values are 80 % area of FOV.

## Hardware requirement

OS	Windows® 10 Pro (64bit) Windows® 11 Pro (64bit)
CPU	Intel® Core(TM) i7-4770 or higher
Memory	16GB以上
HDD	500GB or higher More than 3GB free space is necessary in the system drive (that is a drive where OS is installed). If full size measurement is executed, data size of its result is about 8GB.
USB port	USB3.0 Type-A : 1 port *Please use USB port on the mother board (In case of laptop PC, use USB port on the main body). *Otherwise it may cause malfunction.
USB Host Controller	Intel® USB 3.0 eXtensible Host Controller
USB driver	Microsoft Windows® 10 USB 3.0 driver *Windows® 10 has a native in-box USB 3.0 driver.
Display	1920*1080 or higher, 16.77 million colors (32bit) or higher
Drive	DVD-ROM drive

\*Microsoft and Windows are registered trademark of Microsoft Corp. in the US and other countries.  
\*Intel Core is a registered trademark or trademark of Intel Corporation in the US and other countries.  
\*All other company and product names listed in this sheet are trademarks or registered trademarks of their respective companies.  
\*This specification is based on the test environment of TechnoOptis. Incompatibility problem with individual PC is out of warranty.



\* Some screens are simulated.  
\* The specifications and external appearances of product in this catalogue may be changed without prior notice due to improvements.  
\* The catalogue includes products that are sold separately.  
\* The actual color of products may differ slightly from the catalogue due to lighting and printing conditions.

## TechnoOptis Co., Ltd.

Formerly Topcon Technohouse Corporation

4F, Imas Itabashi Base, 2-4-1, Sakashita, Itabashi-ku, Tokyo 174-0043 JAPAN

Phone: +81-3-3558-2666 Fax: +81-3-3558-4661

E-mail: techno-info@techno-optis.com

### SAFETY PRECAUTIONS



Make sure to carefully read the "Manual" to ensure that you use the product properly and safely.  
• Always connect the instrument to the specified power supply voltage.  
Improper connection may cause a fire or electric shock.  
• Be sure to use the specified batteries.  
Using improper batteries may cause a fire or electric shock.

For more information please visit our website.

<https://www.techno-optis.com/en/>

