

# TechnoOptis

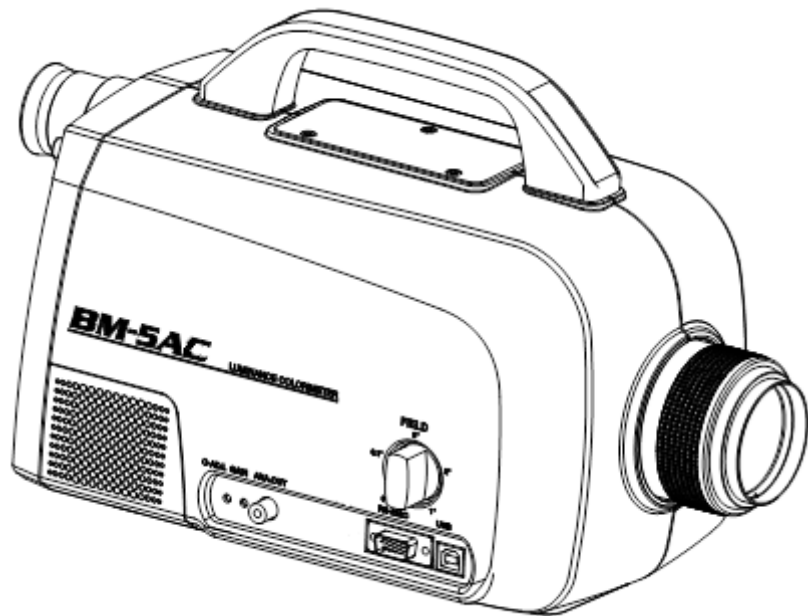

INSTRUCTION MANUAL  
**Luminance Colorimeter**

---

# ***BM-5AC***



# Introduction

---

Thank you for purchasing our product, Luminance Colorimeter BM-5AC.

This instrument is a Luminance Colorimeter for measuring light with high precision from a natural light source such as a CRT, PDP, LCD, LCD backlight, LED, light-storing materials, or the like, or reflected light from a painted surface or printed material.



Read this manual carefully before using the BM-5AC in work applications.

## Precautions for Use

- Use dedicated AC adapter, otherwise it may cause malfunction. For the power supply used for this instrument, the input voltage is 100 to 240 VAC and the frequency is 50 to 60 Hz.
- For energy saving, when this instrument will not be used for an extended period of time, disconnect the power plug from the outlet.
- Keep the instrument away from water and liquid. This instrument is not water-resistant.
- Before using this instrument, be sure to warm it up for at least 30 minutes. If this instrument is not warmed up, output fluctuation may affect the measurement values, preventing highly accurate measurement results from being obtained.
- When using this instrument over a prolonged period of time, calibrate it on average once every 1 hour. Output fluctuation of the photo detector may prevent highly accurate measurement results from being obtained.
- Never measure the light source exceeding the measurable range or the sunlight. Such behaviors may damage the photo detector and make it impossible to perform the stabilized measurement.
- Never use this instrument in the place which is dusty or humid or generates corrosive gas.
- Never use this instrument in a place where the temperature tends to vary rapidly. Although this instrument is equipped with a temperature compensating circuit, it may not perform the stabilized measurement under the environment where the temperature tends to vary rapidly.
- Do not subject this instrument to heavy impact such as dropping it. Also, avoid using or storing this instrument in areas subjected to constant vibration. This instrument uses high-precision optical parts and subjecting it to harsh conditions might cause a malfunction. Prevent this instrument from being subjected to direct vibration or impact by placing it in a carrying case when carrying it.
- Never use or store the instrument in such place as is subject to heavy shock like falling or as tends to vibrate at any time. Such places may damage this instrument equipped with delicate optical components. And, to carry the instrument, please use the accessory carrying case not to directly vibrate or shock it.
- To maintain the measurement precision, be sure to perform the calibration at least once a year. For the calibration adjustment, consult the local retailer from which you purchased the instrument or us.
- To request the calibration adjustment, be sure to put the instrument in the accessory carrying case and put the case in a carton box with cushioning materials packed to send it to the retailer or us.
- When the calibration is adjusted, **all data stored in the instrument are completely removed.** Therefore, be sure to back up the necessary data in your computer before requesting the calibration.
- Please do not peel off the sticker stuck on the back of the main unit. **If you peel it off, all warranty will be invalid.**
- Please check whether there is sufficient space at the instrument installation site or whether it can be used with the cable not tilted.
- We recommend that you remove the cable before moving the instrument.







# Safety Indications

Warnings and Cautions are indicated on this instrument and in the instruction manual to prevent injury to users and others, prevent damage to property or the like, and to ensure safe use of this instrument. After fully understanding the following indications and symbols, carefully read the section "Safety Precautions," and observe all precautions.

Display	Meaning
 <b>Warning</b>	Ignoring this display might result in death or severe injury.
 <b>Caution</b>	Ignoring this indication might result in injury <sup>*1</sup> , or physical damage <sup>*2</sup> .

\*1: This refers to injury such as burns, electric shock or the like that does not require hospitalization or long-term medical attention.

\*2: Physical damage includes damage to the building, property, pets or the like.

Icons	Meaning
	This indicates Hazard Alert (Warning). Specific content is expressed with words or an image located close to the icon. (Example:  Be careful about an electric shock.)
	This icon indicates Prohibition. Specific content is expressed with words or an image located close to the icon. (Example:  Don't touch the operating unit.)
	This icon indicates Mandatory Action. Specific content is expressed with words or an image located close to the icon. (Example:  Install earth ground.)

# Safety Precautions

## **Warning**



**Prohibited**

**Never use the system in flammable or explosive vapor-floated (gasoline, etc.) place.**  
This may cause the fire.



**Prohibited**

**Keep the instrument away from water and liquid.**  
This may cause the fire and electric shock.



**Prohibited**

**Never disassemble or modify the device.**  
This may cause the fire and electric shock.



**Mandatory**

**Be sure to use the dedicated AC adapter.**  
This may cause the fire and electric shock.



**Prohibited**

**Never disassemble AC adapter.**  
This may cause the fire and electric shock.



**Mandatory**

**Be sure to remove the dust or moisture around the outlet.**  
This may cause the fire.



**Mandatory**

**If abnormal sound, unusual smell, or smoke are found in the device, turn off the power quickly and pull out the AC adapter cable from the outlet.**  
Continuing to use the device may cause the fire.

## **Caution**



**Never watch the sun or the filament of an electric bulb directly.**  
This may injure your eyes.

**Prohibited**



**Never put the device (or other objects) on the unstable places like wobbly table or inclined surface.**

**Prohibited**

Dropping or falling of the device (or other objects) may injure you.



**Never pull out or insert the plug by wet hands.**  
This may cause you electric shock.

**Prohibited**



**Use only specified screws when using the tripod screw and screw holes for jig attachment.**

**Mandatory**

Do not tighten the screws any more than necessary. Doing so might cause internal breakage.

## **Disclaimer**

- We are not responsible for the damages caused by various problems such as, fire, earthquake, behaviors by other persons, other accidents, intentional or negligent or wrong use of the device by the operator, and the use of the device under abnormal conditions.
- We are not responsible for incidental damages arising from the use or unavailability of the device (loss of business income, business interruption, etc.).
- We are not responsible for the damages caused by the uses other than specified in the Instruction Manual.
- We are not responsible for the damages caused by the malfunction due to the combination with the connecting devices.

## **User Maintenance**

To maintain safety and performance, any maintenance work other than that explained in this instruction manual should be performed only by a qualified service representative. The following maintenance, however, can be performed by the user.

### **Cleaning the Cover and Lens**

When the cover or lens becomes dirty, wipe the case or lens with a soft cloth that has been dampened with mild detergent, and then dry with a dry soft cloth.

Do not use solvents such as paint thinner, benzene, acetone or the like. Doing so may discolor the surface.

### **Cleaning the Fanmotor Filter**

A dustproof filter has placed to fan motor on the main body side. When dust adheres to this filter, internal heat radiation is hindered. Please wash the filter regularly with the mild detergent.

# Table of Contents

Introduction .....	1
Safety Indications.....	2
Safety Precautions.....	3
Notation Rules Used in This Manual .....	8
<b>1. Before Use.....</b>	<b>9</b>
1.1 Checking the Unit and Supplied Parts.....	9
1.2 Part Names and Functions.....	10
1.3 Preparation .....	15
1.4 Error Display .....	21
<b>2.Measurement Operation.....</b>	<b>22</b>
2.1 Basic Measurement .....	22
2.1.1 Measuring the Light Source Color.....	22
2.1.2 Measuring Object Color.....	23
2.1.3 Absolute Value Measurement.....	24
2.1.4 Measuring Difference.....	24
2.1.5 Measurement Result Display Mode .....	25
2.2 Various Measurement Examples.....	26
2.2.1 Measuring a Light Source With Directivity.....	26
2.2.2 Measuring Minute Surfaces .....	26
2.2.3 Using the Instrument in Another System.....	27
2.2.4 Reducing Error between Multiple Luminance Colorimeters and Performing Measurement .....	27
2.2.5 Using the Analog Output Connector .....	33
<b>3. Various Settings .....</b>	<b>35</b>
3.1 Function Mode .....	35
3.1.1 Entering/Returning from Function Mode.....	35
3.1.2 Displaying Data/Setting Items.....	36
3.1.3 Display Screens.....	37
3.1.4 Entering Numerical Values .....	40
3.2 Detailed Explanation of Function Mode.....	41
3.2.1 Selecting Light Source/Object Color.....	41
3.2.2 Selecting Measurement of Absolute Values/Difference.....	45
3.2.3 Setting the Averaging Count.....	46
3.2.4 Correction Factor.....	47
3.2.5 Area Correction Factor.....	57
3.2.6 Selecting the Interface .....	61
3.2.7 RS-232C Parameters .....	62
3.2.8 Measurement Range .....	63
3.2.9 Setting the Measurement Mode .....	65
3.2.10 Selecting Filters in the Tristimulus Value Fixed Mode .....	66





3.2.11	Selecting the Analog Output Response Speed (Analog Waveform Observation).....	67
3.2.12	Buzzer Sound.....	68
3.2.13	Communication Format.....	68
3.2.14	Color Adjustment.....	69
3.2.15	Range Retry Count.....	69
<b>4.</b>	<b>Communication With a PC.....</b>	<b>70</b>
4.1	Communication Commands.....	70
4.2	BM-5AC Mode Communication Commands.....	70
4.2.1	ST Command.....	73
4.2.2	CA Command.....	74
4.2.3	TF Command.....	74
4.2.4	TS Command.....	74
4.2.5	RA0/RA1 Commands.....	74
4.2.6	RM0/RM1 Commands.....	75
4.2.7	R Commands.....	75
4.2.8	X / Y / Z Commands.....	75
4.2.9	AN/AF Commands.....	75
4.2.10	FX/FY/FZ Commands.....	76
4.2.11	FR Command.....	76
4.2.12	F Commands.....	76
4.2.13	RF Command.....	76
4.2.14	WF Command.....	77
4.2.15	CF Command.....	77
4.2.16	FK Command.....	77
4.2.17	FKR Command.....	78
4.2.18	FAG Command.....	78
4.2.19	FO Command (O: alphabet).....	78
4.2.20	CGL Command.....	78
4.2.21	FGR Command.....	79
4.2.22	RGmKn Command.....	79
4.2.23	RGmLn Command.....	79
4.2.24	WGmKn Command.....	80
4.2.25	WGmLn Command.....	80
4.2.26	WHO/VER/SRL Command.....	80
4.2.27	SCC Command.....	80
4.2.28	LCC Command.....	81
4.3	Remote Measurement Output Format.....	82
4.4	BM-5A Mode Communication Commands.....	83
4.5	Error Codes.....	85
<b>5.</b>	<b>USB Driver.....</b>	<b>86</b>
	<b>Appendix.....</b>	<b>88</b>

Specifications.....	88
Appended Tables .....	92
System Diagrams.....	93
External Dimensions .....	94
Internal Calculation Processing.....	95
Terminology .....	97
<b>Warranty .....</b>	<b>98</b>
<b>Contact information: .....</b>	<b>99</b>

# Notation Rules Used in This Manual

---

The following notation rules are used in this manual.

Notation	Explanation
[MODE], [UP]	Indicates panel switches or titles of screens displayed on the display.
 「」	Indicates a reference location in the manual.
 『』	Indicates another manual used as a reference.
 <b>Request</b>	Indicates items to keep in mind when performing an operation, or items that require attention.
 Memo	Indicates items to consider when performing an operation or information that is useful.

# 1. Before Use

## 1.1 Checking the Unit and Supplied Parts

---

Make sure that the main unit and all of the accessories are in proper order.

If there are any missing parts, contact your dealer or TechnoOptis.

- Main unit 1
- Objective lens cap 1
- Carrying case 1
- Instruction manual (Quick manual) 1
- AC adapter 1
- CD-ROM 1  
(Instruction Manual, Colorimetry program CS-900A)
- USB cable 1
- Analog output plug 1
- Inspection report 1

# 1.2 Part Names and Functions

## ■ Main Unit

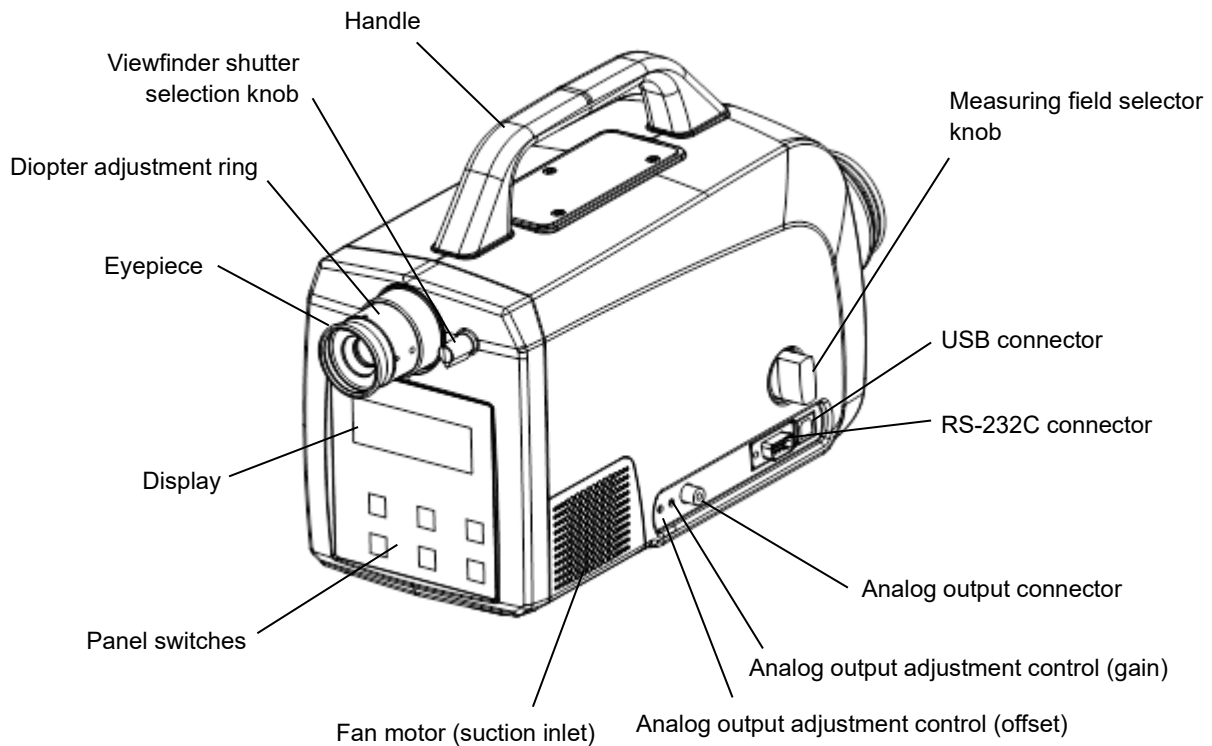

Name	Function
Diopter adjustment ring	Used to adjust the focus of the reticle mark in the viewfinder.
Viewfinder shutter selection knob	Incident light from the viewfinder can be blocked by setting this knob to the CLOSE position. When incident light from the viewfinder affects the measurement results, for example, when the incident light is strong or when measuring objects in weak light conditions, set the viewfinder shutter selection knob to the CLOSE position.
Display	Backlit display for displaying various kinds of information such as measurement results and measurement conditions.
Panel switches	Switches for starting/stopping measurement, for selecting measurement conditions, and for performing calibration. These switches also can be used for setting the various conditions in the function mode.  "■ Panel Switches"
Measuring field selector knob	Used for selecting the measuring field. The measuring field and size of the measurement area differ depending on the measuring field.  "Appendix: Specifications"
USB connector	Connector for connecting the USB cable when performing measurement in the remote mode.  "1.3 Preparation"
RS-232C connector	Connector for connecting the RS-232C cable when performing measurement in the remote mode.  "1.3 Preparation"

Analog output connector	Connector used for observing analog output. The output of the photo detector can be observed as a voltage value. ☞ "2.2.5 How to Use the Analog Output Connector"
Analog output adjustment control (gain)	Control for adjusting analog output gain. The maximum output voltage value is approx. 4V.
Analog output adjustment control (offset)	Control for adjusting analog output offset.

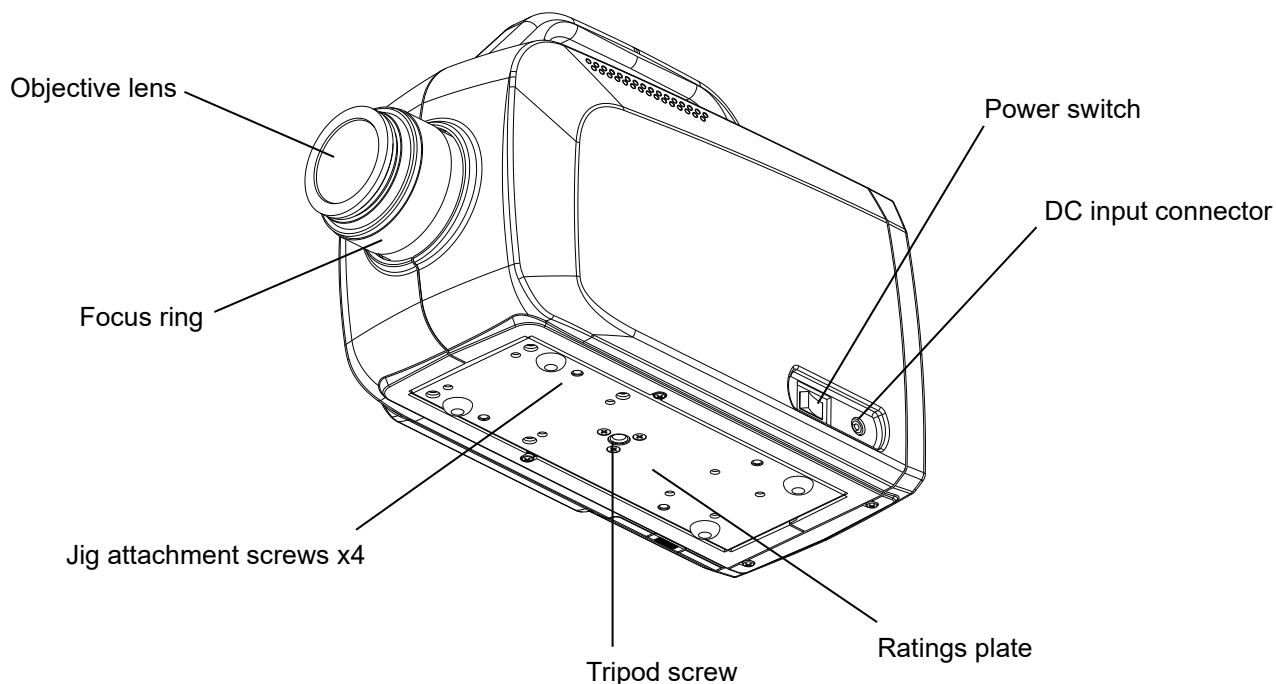

Name	Function
Power switch	Power switch for the instrument.
DC input connector	Connector for plugging in the output plug from the AC adapter supplied with the instrument.
Focus ring	Used for adjusting the focus of the measurement object.
Tripod screw	Screw used when attaching the instrument to a tripod. A tripod mount for JIS B 7103-1975 cameras is used for the screw. Nominal designation: 1/4-20UNC Number of threads: 20 Pitch: 1.270 mm Depth: 6 mm
Jig attachment screws	Screws used when fitting into a system and for attaching the instrument. M4 x 0.7 (Diameter: 4 mm Pitch: 0.7 mm) screws. Details ☞ "Appendix: External Dimensions"

 <b>Request</b>	Use only specified screws when using the tripod screw and screw holes for jig attachment. Do not tighten the screws any more than necessary. Doing so might cause internal breakage.
--------------------	--

## ■ Panel Switches

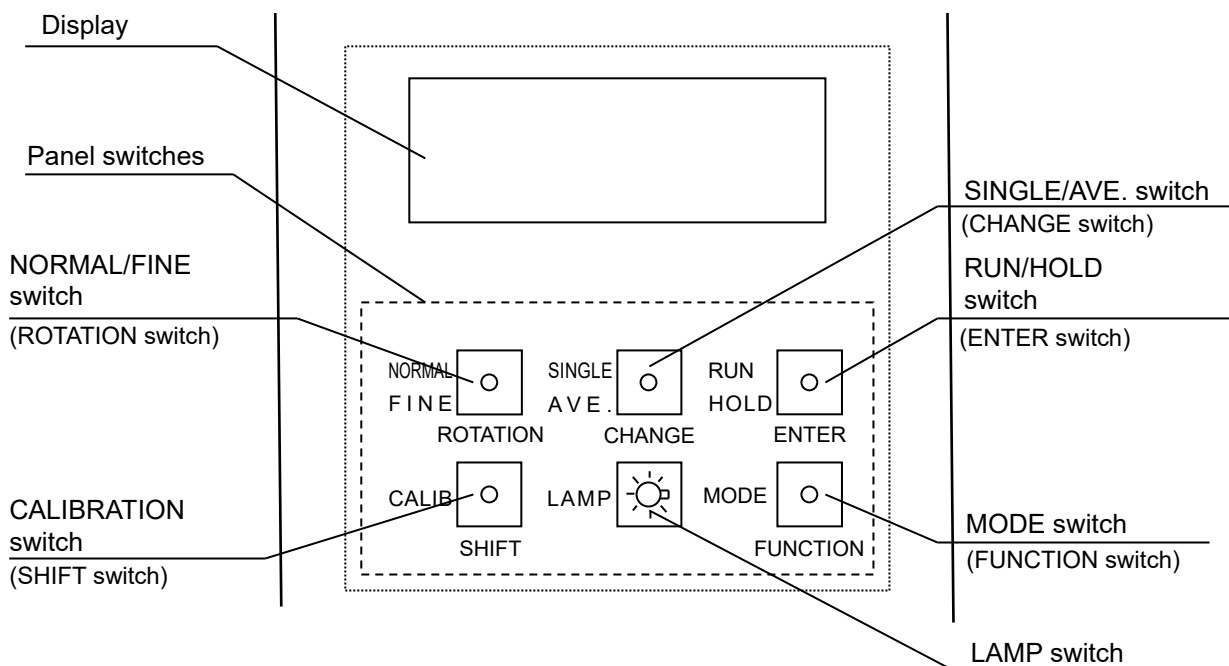

The panel switches have the following two functions:

- Functions used for measurement (displayed on left side of switch)
- Functions used for function mode (displayed on the bottom of switch)

### Functions used for measurement

Name	Function
NORMAL/FINE switch	Switches the measurement range setting. NORMAL Measurement is performed in the same measurement range for all tristimulus values $X_2YZ$ . FINE Measurement is performed in ideal measurement ranges for each of $X_2YZ$ . Memo This switch is enabled when AUTO is set in the function mode.
SINGLE/AVE. switch	Switches the averaging measurement setting. SINGLE Averaging is not performed. The results of only 1 measurement are displayed. AVERAGE Averaging is performed. Measurement is performed for the number of times set in the function mode, and the average value is displayed as the measurement result.
RUN/HOLD switch	Switches measurement start/stop.
CALIBRATION switch	This switch is used to perform calibration. Calibration maintains the photo detector at a constant sensitivity level to ensure stable measurement.
LAMP switch	Switches the backlight ON/OFF. The backlight is set to ON when the power is turned ON.

MODE switch	<p>Switches the color coordinate system displayed on the display. When this switch is pressed with measurement stopped (MEAS./HOLD switch set to HOLD), the color coordinate system displayed on the display is switched in the following order:</p> <p>xy/L → u'v'/L → XYZ → Tc/duv/L</p>  <p>This switch is set to the xy/L mode when the power is turned ON.</p>
-------------	---

## Functions used for the function mode

Name	Function
FUNCTION switch	This button is used to enter and return from the function mode. To enter the function mode, hold down this switch for about 2 seconds. Pressing this switch again returns the mode to the measurement mode.
ENTER switch	This button is used to change the display page and to store data to memory after entering values.
CHANGE switch	This switch is used to change settings. When this switch is pressed, the cursor flashes. Enter the new data in this state.
ROTATION switch	<p>This switch is used to select parameters. Each press of this switch successively displays selection candidates. The displayed content differs according to the parameter type.</p> <p>Example: · → 0 → 1 → 2 → ..... → 8 → 9 → + → - → E → · →            ..... 2400 → 4800 → 9600 → 19200 → 38400 → 2400 →            ..... EVEN → ODD → NONE → EVEN → .....</p>
SHIFT switch	<p>This switch is used to move the entry digit when entering numerical values for multiple digits.</p> <p>The entry digit moves from the highest order digit to the lowest order digit.</p>

1. Before Use

## ■ Display

• Top screen

This screen is displayed when the power is turned ON.

```

** Start BM-5AC **
** Ver *.* **
    
```

• Calibration execution screen

This screen is displayed when calibration is being executed.

```

Calibrating
    
```

### Measurement result display screens

This screen is displayed after measurement ends.

#### Absolute value measurement ABS/ Difference measurement DIF

Measuring Field  
3 deg/2 deg/1 deg/  
0.2 deg/0.1 deg

#### Correction factor

00 : No correction factor  
01 - 10 : Correction factor number

#### Correction factor group

00-0 : No correction factor group  
xx-y : Correction factor group  
xx : 01 - 10 y : 1 - 5

Luminance/  
chromaticity mode  
L x y

```

F2.0 ABS K00 G00-0
x = 0.4476 --
y = 0.4074
L = 1.000E+02 cd/m^2
    
```

Under range display

Luminance/  
chromaticity mode  
L u' v'

```

F2.0 ABS K00 G00-0
u' = 0.2560
v' = 0.5242
L = 1.000E+02 cd/m^2
    
```

Tristimulus value  
mode  
X Y Z

```

F2.0 ABS K00 G00-0
X = 1.099E+02
Y = 1.000E+02 cd/m^2
Z = 3.559E+01
    
```



Color temperature/  
deviation/luminance  
mode  
Tc duv L

```

F2.0 ABS K00 G00-0
Tc = 2856
Duv = 0.000
L = 1.000E+02 cd/m^2
    
```

## 1.3 Preparation

### ■ Connecting the AC Adapter

 Mandatory	<b>Be sure to use the dedicated AC adapter.</b> This may cause the fire and electric shock.
 Mandatory	<b>Be sure to remove the dust or moisture around the outlet.</b> This may cause the fire.
 Prohibited	<b>Never pull out or insert the plug by wet hand.</b> This may cause electric shock.

The following explains the procedure for connecting the AC adapter to the instrument.

- 1 Make sure that the instrument is turned OFF.

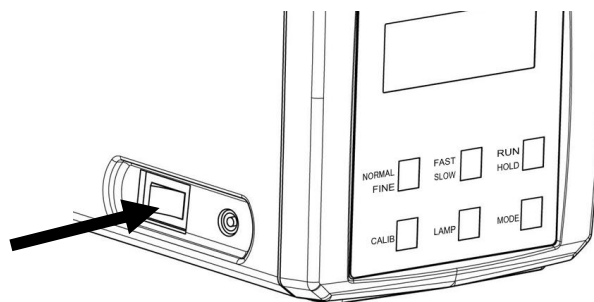

- 2 Insert the connector on the output side of the AC adapter to the DC input connector of the instrument.

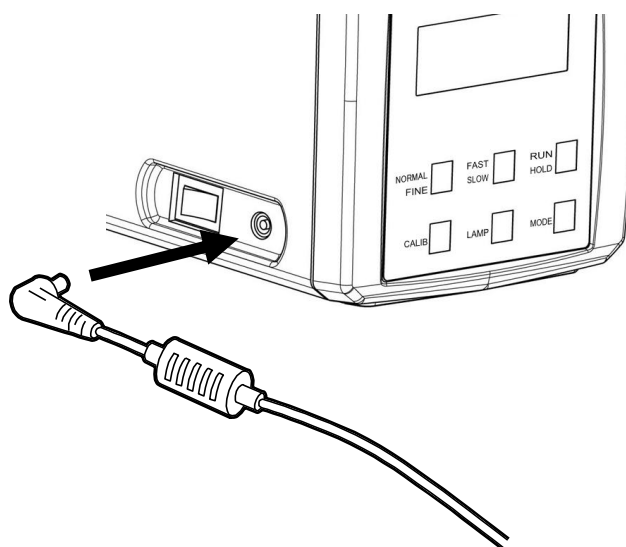

1. Before Use

- 3 Plug the AC adapter plug into the power outlet.

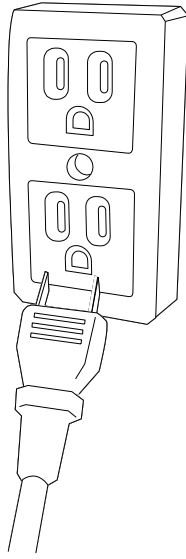

## ■ Connecting to a PC

When connecting the BM-5AC to a PC, use an RS-232C cable or USB cable. When using an RS-232C cable, use a DOS/V PC-compatible straight cable. Up to 16 instruments can be connected to a single PC using the USB cable. Joint use of the USB cable with the RS-232C interface also is possible. Note, however, that the USB and RS-232C cables cannot be used at the same time on a single BM-5AC.

### Memo

- The RS-232C connection cables are not supplied with the main unit. They should be purchased separately.
- For details regarding the connection on the PC side, refer to the manual for the PC being used.

### USB connection

- BM-5AC side -

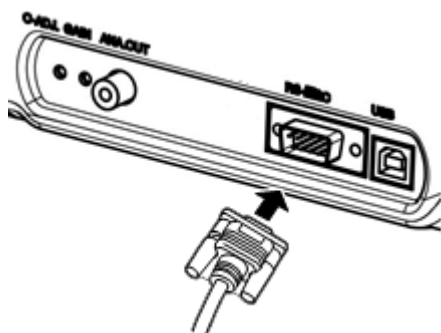

- PC side -

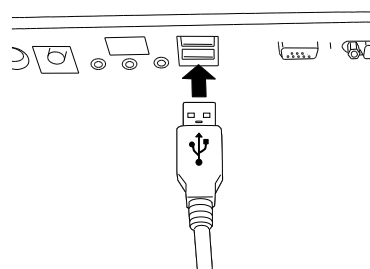

### RS-232C connection

- BM-5AC side -

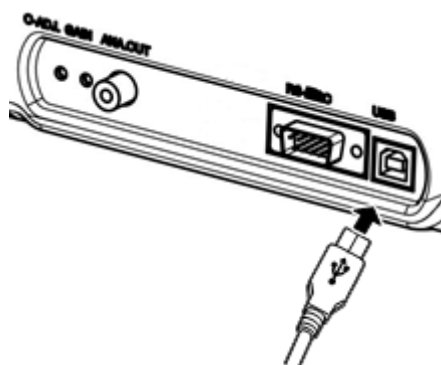

- PC side -

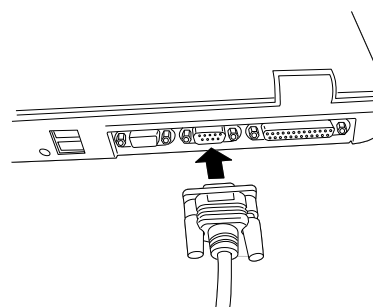

The RS-232C specifications for the instrument are as follows.

- |                        |  |
|------------------------|--|
| • Cable                | DOS/V PC-compatible straight cable   |
| • Transmission mode    | Full duplex  |
| • Synchronous system   | Start-stop synchronization   |
| • Baud rate            | 2400/4800/9600/19200/38400 bps   |
| • Bit configuration    | Data length 7 bits/8 bits<br>Parity EVEN/ODD/NONE<br>Stop bit 1 bit/2 bits |
| • Communication format | ASCII format   |
| • Delimiter            | "CR+LF" or "CR" are added to the end of the communication data strings.    |

### Instrument settings

To use the instrument connected to a PC, make the following settings in the function mode.

- Interface selection RS-232C/USB "3.2.6 Selecting the Interface"
- Selecting RS-232C communication parameters "3.2.7 RS-232C Parameters"

## ■ Collimation of the Measurement Object



Prohibited

**Do not look directly at bright lights such as the sun or light bulb filaments.**  
Doing so might damage your eyes.



**Request**

Use only specified screws when using the tripod screw and screw holes for jig attachment. Do not tighten the screws any more than necessary. Doing so might cause internal breakage.

- 1 Set the instrument on a tripod or the like.
- 2 Remove the cap from the objective lens.
- 3 Set the viewfinder shutter to OPEN.
- 4 Look into the eyepiece, and turn the diopter adjustment ring of the eyepiece so that the reticle marks are clearly seen in the view finder.

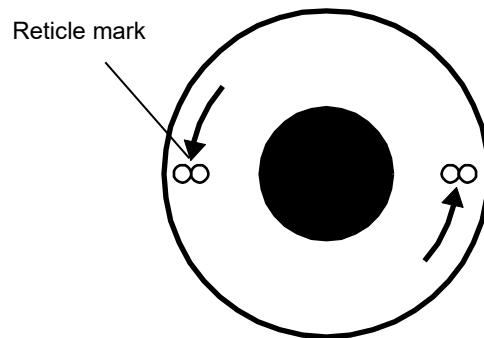

- 5 Collimate the measurement object, and turn the focus ring of the objective lens to adjust the focus on the measurement object.
- 6 Change the measuring field according to the size and brightness of the measurement object.

### Memo

- When changing the measuring field, use the measuring field selector switch.
- The current measuring field is displayed on the display.

Measuring field selector switch, LCD display  "1.2 Part Names and Functions"

- The measurable luminance range differs according to the measuring field.

 "Appendix: Specifications Luminance Display Ranges"

## ■ Turning the Power ON/OFF

 <b>Request</b>	<p><b>Warming Up Recommendation</b></p> <ul style="list-style-type: none"> <li>· Be sure to warm up the instrument for at least 30 minutes so that measurement can be performed at high precision.</li> <li>· <u>After warming up has ended, be sure to press the CALIB switch to execute calibration.</u></li> </ul>
---	---

### • Turning the power ON

Flip the power switch to the left to turn the power ON.

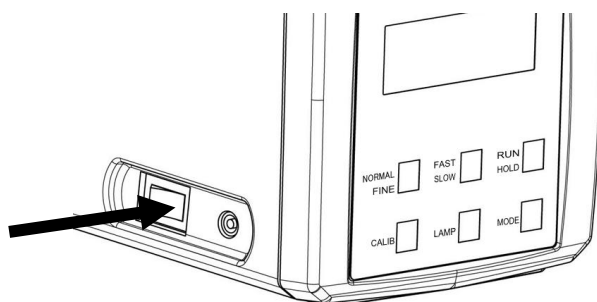

The top screen and calibration execution screen are displayed followed by the measurement screen.

Top screen

```

** Start BM-5AC **
** Ver *.* **

```

Calibration execution screen

```

Calibrating

```

Measurement screen

```

F2.0 ABS K00 G00-0
x= 0.4476
y= 0.4074
L= 1.000E+02 cd/m^2

```

## 1. Before Use

### Memo

- When BM-5A is selected at communication format, BM-5AC becomes a remote mode after the power is turned ON. BM-5AC cannot be used in a local mode.

 "3.2.13 Communication Format"

### ▪ **Turning the power OFF**

To turn the power OFF, flip the power switch to the right.

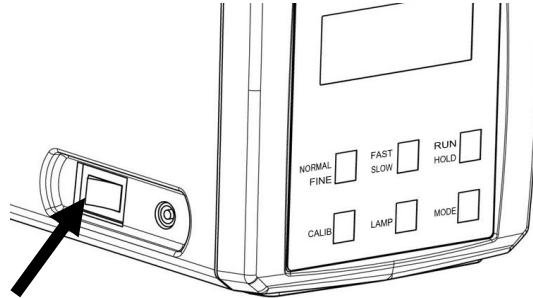

## 1.4 Error Display

When an error occurs on the instrument, an error is displayed.

Error Display	Description
FERR	This is displayed when the measuring field is not properly set. Check the measuring field selector switch, and make sure that the measuring field is set properly.
*****	This is displayed when the luminance of the measurement object exceeds the measurement range of the instrument (Over Range). Check the measurement range. Measurement range ☞ "Appendix: Specifications Luminance Display Ranges" When it is not possible to change the measuring field or measurement range, use a dark filter (optional).
-- --	This is displayed when the luminance of the measurement object exceeds the measurement range of the instrument (Under Range). When measurement is being performed by manual range, set the measurement range to the low-luminance side. The specification accuracy might not be satisfied when measurement is performed by auto range. Measurement range ☞ "Appendix: Specifications Luminance Display Ranges"
Time out	This is displayed when data communication cannot be performed between two luminance colorimeters when the direct correction function is set. Make sure that the RS-232C parameter settings, transmission mode and data output method of the two luminance colorimeters are set to the same values. Details☞ "2.2.4 Reducing Error Between Multiple Luminance Colorimeters and Performing Measurement"
Different Device	This is displayed when the model name of reference colorimeter set on the BM-5AC differs from the model name of the colorimeter that is the actual reference when the direct correction function is set. Check the model name of reference colorimeter setting on the BM-5AC. Details☞ "2.2.4 Reducing Error Between Multiple Luminance Colorimeters and Performing Measurement"
OVER	This is displayed when the luminance of the measurement object exceeds the measurement range of the instrument (Over Range) when the direct correction function is set. Check the measurement range. Measurement range ☞ "Appendix: Specifications Luminance Display Ranges" When it is not possible to change the measuring field or measurement range, use a dark filter (optional).
Under	This is displayed when the luminance of the measurement object exceeds the measurement range of the instrument (Under Range) when the the direct correction function is set. Check the measurement range. Measurement range ☞ "Appendix: Specifications Luminance Display Ranges"
***Field*** ERROR	This is displayed when the measuring field is not properly set when the direct correction function is set. Check the measuring field selector switch, and make sure that the measuring field is set properly.
*** ERROR *** Internal Communication	Initialization communication error. The power OFF then back ON again.

# 2.Measurement Operation

## 2.1 Basic Measurement

This section describes basic measurement methods.

### 2.1.1 Measuring the Light Source Color

The following describes the procedure for measuring the light source color.

- 1 Turn the instrument ON, and display the measurement screen.

```
F 2. 0 ABS K00 G00-0
      x= 0. 3333
      y= 0. 3333
L= 5. 555E+01 cd/m^2
```

- 2 Make sure that the mode is the light source mode (SOURCE) in the function mode.

 "3.1.1 Entering/Returning from the Function Mode"

```
* SOURCE / OBJECT *
      SOURCE
```

SOURCE: light source color/OBJECT: object color

- 3 Press the [RUN/HOLD] switch to start measurement.
- 4 To stop measurement, press the [RUN/HOLD] switch.

## 2.1.2 Measuring Object Color

The following describes the procedure for measuring the color of an object.

- 1 Turn the instrument ON, and display the measurement screen.

```
F 2 . 0  A B S  K 0 0  G 0 0 - 0
      x = 0 . 3 3 3 3
      y = 0 . 3 3 3 3
      L = 5 . 5 5 5 E + 0 1  c d / m ^ 2
```

- 2 Set the object color mode (OBJECT) in the function mode, and enter the luminance factor of the white board.

☞ "3.1.1 Entering/Returning from the Function Mode"  
Details ☞ "3.2.1.1 Setting Measurement of Object Color"

### Memo

- The white board is used for measuring the light source used for measuring the color of objects.
- The factory setting for the white board luminance factor is 100.0%.

- 3 Exit the function mode, and return to the measurement screen.
- 4 Press the [RUN/HOLD] switch. The following white board measurement message is displayed. Place the white board under the light source, and press the [RUN/HOLD] switch to measure the luminance and chromaticity of the light source.

```
A t t e n t i o n ! !
P l e a s e  s e t
t h e  W S  ( x x x . x % ) ,  t h e n
p u s h  R U N / H O L D  k e y .
```

### Request

- Before measuring the white board, be sure to set the correct luminance factor.  
Correct measurement results cannot be obtained if the luminance factor is set incorrectly.
- Use a TechnoOptis standard white board WS-3.

- 5 Place the white board under the light source, and press the [RUN/HOLD] switch to measure the luminance and chromaticity of the light source. After measurement ends, the measurement results are displayed for about 3 seconds, and sample measurement is started.

```
*      W H I T E  B O A R D      *
X =  x . x x x E + x x
Y =  x . x x x E + x x  c d / m ^ 2
Z =  x . x x x E + x x
```

- 6 Place the measurement object under the light source, and measure the object.

### Memo

- The measurement results of the white board are lost when the following operation is performed:  
The object color mode or white board luminance factor is changed in the function mode.  
The power is turned OFF.
- When re-measuring the white board, repeat the above procedure from Step 2.

## 2.1.3 Absolute Value Measurement

The following describes the procedure for measuring absolute values.

- 1 Set to the absolute value measurement mode (ABSOLUTE) in the function mode.

"3.1.1 Entering/Returning from the Function Mode"

- 2 Press the [RUN/HOLD] switch to start measurement.
- 3 To stop measurement, press the [RUN/HOLD] switch.

```

F 2. 0 ABS K00 G00-0
      x= x. xxxxx
      y= x. xxxxx
      L= x. xxxxE+xx cd/m^2
    
```

## 2.1.4 Measuring Difference

On this instrument, you can measure the difference from reference data.

The following explains the procedure for measuring difference.

- 1 Set to the difference measurement mode (DIFFERENCE) in the function mode.

"3.1.1 Entering/Returning from the Function Mode"

- 2 The following screen is displayed when the difference mode is set after the instrument is turned ON.

```

      Attention!!
Please set
The Std. sample, then
push RUN/HOLD key.
    
```

- 3 Set the reference sample in place, and press the [RUN/HOLD] switch.

After measurement, the measurement result is displayed for about 3 seconds, then continuous difference measurement is performed automatically.

```

* STANDARD SAMPLE *
      x= x. xxxxx
      y= x. xxxxx
      L= x. xxxxE+xx cd/m^2
    
```

<b>Request</b>	<ul style="list-style-type: none"> <li>· Reference data is stored internally until the power is turned OFF. The reference data is not measured even if DIFFERENCE is set after DIFFERENCE is changed to ABSOLUTE in the function mode. To change the reference data, the power OFF then back ON again, and repeat the procedure from step 1.</li> </ul>
----------------	---

Memo

<ul style="list-style-type: none"> <li>· Stored reference data can be checked in the function mode.  <div style="text-align: right;">Checking reference data  "3.2.2.1 Measuring Difference"</div> </li> </ul>
--

## 2.1.5 Measurement Result Display Mode

When the display is in the HOLD mode ([HOLD] on the RUN/HOLD switch is blinking), you can change to the measurement result display mode by pressing the MODE switch. Each press switches the display as follows:

### - Light Source Color -

#### Chromaticity xy Luminance L

```
F2.0 ABS K00 G00-0
      x= 0.3644
      y= 0.5097
L= 2.884E+01 cd/m2
```

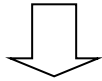

#### Chromaticity u'v' Luminance L

```
F2.0 ABS K00 G00-0
      u'= 0.1738
      v'= 0.5469
L= 2.884E+01 cd/m2
```

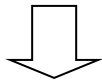

#### Tristimulus value XYZ

```
F2.0 ABS K00 G00-0
      X= 2.062E+01
      Y= 2.884E+01 cd/m2
      Z= 7.126E+00
```

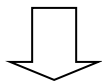

#### Color temperature Tc Deviation duv Luminance L

```
F2.0 ABS K00 G00-0
      Tc = 4903K
      duv= 0.077
L= 2.884E+01 cd/m2
```

### - Object Color -

#### Chromaticity xy Luminance L

```
F2.0 ABS K00
      x= 0.3011
      y= 0.3455
L= 1.732E+01 cd/m2
```

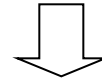

#### CIE 1976 (L\*a\*b\* color space) ※DIF

```
F2.0 ABS K00
      a*= -7.5
      b*= -8.4
L*= 45.4 ※ Eab=5.4
```

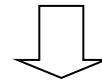

#### CIE 1976 (L\*u\*v\* color space) ※DIF

```
F2.0 ABS K00
      u*=-13.3
      v*=-8.4
L*= 45.4 ※ Euv=5.4
```



## 2.2.3 Using the Instrument in Another System

When using the instrument in another system such as an XY stage, install it on the system using the jig attachment screws on the base of the instrument.

Also, connect the instrument to a PC using the RS-232C or USB interface.

When using the unit in a system, refer to the following.

Communication specifications  "4. Communication with a PC"

Installation data  "Appendix: External Dimensions"

## 2.2.4 Reducing Error between Multiple Luminance Colorimeters and Performing Measurement

When measuring the same measurement target using multiple colorimeters, the same measurement results sometimes cannot be obtained because of differences in the characteristics of each colorimeter. If this happens, perform correction for matching the values to the measurement results of specific colorimeters.

The instrument has built-in functions for storing correction factors to memory and applying them. These functions can be used to reduce error between multiple colorimeters.

There are 3 methods of performing correction between colorimeters as follows:

- Use software CS-900A.
- Use the Direct Correction function.
- Use the correction factor function in the function mode.

Correction factor  "3.2.4 Correction Factor"

### ■ Using CS-900A

For this method, a reference light source sample is required.

The reference light source sample should be the same kind of light source as the light source actually being measured, and should have stable light output.

The procedure for performing correction between instruments using CS-900A, refer to the [CS-900A INSTRUCTION MANUAL].

### ■ Using the Direct Correction Function

When using the Direct Correction function, a RS-232C cable and a reference light source sample are required.

 <b>Request</b>	<ul style="list-style-type: none"> <li>· The reference light source sample should have stable light output and be the same type as the light source actually being measured.</li> <li>· To use the Direct Correction function, the RS-232C parameters of the 2 luminance colorimeters must be the same.</li> </ul>
---	--

When using the Direct Correction function, first, measure the light source using the reference instrument, and write that measurement data to the BM-5AC to be corrected.

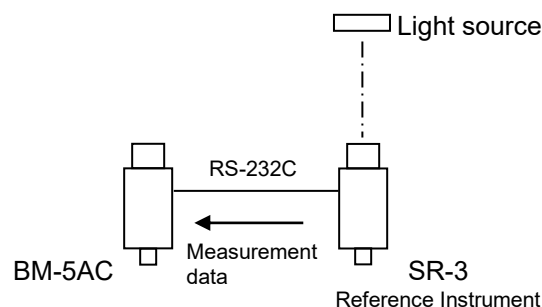



- 7 Press the [ROTATION] switch, select "MEASURE REFERENCE" ("\*" is displayed), and press the [ENTER] button.  
 MEASURE REFERENCE : Perform measurement on the reference instrument, and write the measurement data to the BM-5AC to be corrected.  
 MEASURE FACTOR : Measurement is performed using the BM-5AC to be corrected, then the correction factor is calculated based on data obtained by "MEASURE REFERENCE".  
 ALL FACTOR CLEAR : The correction factor and measurement data obtained above are cleared.

```

*DIRECT-CONN FACTOR*
  *MEASURE REFERENCE
    MEASURE FACTOR
      ALL FACTOR CLEAR
  
```

- 8 Select the type of the reference instrument.  
 Press the [ROTATION] switch and select the type of the reference instrument ("\*" is displayed), then press the [ENTER] button. For the BM-5AC, select "COMMON".

```

SELECT REF DEVICE
  COMMON
  *SR-3
    SC-777
  
```

- 9 Select the data number to be written.  
 Press the [ROTATION] switch to display the number of the data to be written.

```

REF 11
  NO DATA
  R=NEXT S=PAGE
  
```

[ROTATION] : The data of the next number is displayed.

[SHIFT] : Each press switches the display as follows:

REF→SMP→K→...

REF : This stands for "reference". The measurement data of the reference instrument is written.

SMP : This stands for "sample". The measurement data of the instrument to be corrected is written.

K : This stands for "correction factor". The correction factor calculated based on data measured using REF and SMP, is automatically entered.

 Memo

- Up to 5 correction factor data can be stored to memory.

- 10 Press the [CHANGE] switch. The [\*DIRECT-CONN FACTOR\*] screen is displayed.

```
*DIRECT-CONN FACTOR*
  *MEASURE REFERENCE
    EXIT
```

```
REF11  x=0.3560
        y=0.3770
        L=1.806E+02
        R=NEXT S=PAGE
```

```
K11
      NO DATA

      R=NEXT S=PAGE
```

- 11 Press the [ENTER] button. "Measuring" is displayed on the display, and measurement is started by the reference instrument. After measurement ends, the following screen is displayed.

<b>* Request</b>	<p>· Data communication cannot be performed if the various communication settings have not been set correctly. Check whether settings have been set properly according to the Error display.</p> <p style="text-align: right;">Meaning of error displays  "1.5 Error Display"</p>
----------------------	--

- 12 Place the BM-5AC to be corrected in the location where the reference instrument was placed, then press the [ENTER] button to display the following screen.

```
*DIRECT-CONN FACTOR*
  MEASURE REFERENCE
  MEASURE FACTOR
  ALL FACTOR CLEAR
```

- 13 Press the [CHANGE] switch. Press the [ROTATION] switch, select "MEASURE FACTOR" ("\*" is displayed), and press the [ENTER] button.

```
*DIRECT-CONN FACTOR*
  MEASURE REFERENCE
  *MEASURE FACTOR
  ALL FACTOR CLEAR
```

- 14** Specify a number to write the data for the BM-5AC to be corrected. Select a number containing the data of the reference instrument, and press the [CHANGE] button.

 Memo

• If the data "REF" of the reference instrument is not entered at the number to write the data to, measurement cannot be performed.

K 1 1  
NO DATA  
R=NEXT S=PAGE

- 15** The [\*DIRECT-CONN FACTOR\*] screen is displayed. Select "MEASURE FACTOR" ("\*" is displayed) and press the [ENTER] button.

\*DIRECT-CONN FACTOR\*  
\*MEASURE FACTOR  
EXIT

- 16** "MEASURING" is displayed on the display, and measurement is started by the instrument to be corrected. After measurement ends, the correction factor is calculated, and the following screen is displayed.

K 1 1 KX= 9.343E-01  
KY= 9.589E-01  
KZ= 9.396E-01  
R=NEXT S=PAGE

- 17** To enable the calculated correction factor, press the [ENTER] button twice. [\*FACTOR NUMBER\*] is displayed.

\* FACTOR NUMBER \*  
SET FACTOR OFF

- 18** Press the [CHANGE] switch. The following screen is displayed.

SET FACTOR  
DISP&SET  
OFF  
\*BACK

- 19** Press the [ROTATION] switch to move the selection cursor "\*" to "DISP&SET".

SET FACTOR  
\*DISP&SET  
OFF  
BACK

- 20** Press the [ENTER] button to display the correction factor screen.

K 1 1	KX=	9.343E-01
	KY=	9.589E-01
	KZ=	9.396E-01
C=SET	R=NEXT	S=PAGE

- 21** Press the [ROTATION] switch to display the correction factor number to enable, and press the [CHANGE] switch. "SET" is displayed, and the selected correction factor is enabled.

K 1 1	KX=	9.343E-01
SET	KY=	9.589E-01
	KZ=	9.396E-01
C=SET	R=NEXT	S=PAGE

- 22** Press the [FUNCTION] switch. The mode returns to the previous mode, and the correction factor is enabled.

Entering the function mode  "3.1.1 Entering/Returning from the Function Mode"

## 2.2.5 Using the Analog Output Connector

Use the analog output connector to observe the characteristics of a flashing light source etc.. This connector is connected to an oscilloscope, for example, so that characteristics can be observed.

Example) Rise and fall response characteristics, frequency, etc. of a flashing light source

Such characteristics are observed by selecting and fixing one of the built-in tristimulus value filters X<sub>2</sub> / Y / Z, and extracting analog output from the photo detector from the analog output connector.

Function mode  "3.2.9 Setting the Measurement Mode"

Function mode  "3.2.10 Selecting Filters in the Tristimulus Value Fixed Mode"

Function mode  "3.2.11 Selecting the Analog Output Response Speed"

### ■ Relationship between analog output voltage and luminance

The following table summarizes the relationship between analog output voltage and luminance when the tristimulus value filter Y is used. The output voltage range in each of the measurement ranges is 0 to 3.0 V (factory setting).

The measurement result displayed on the display and values output by communications under digital correction undergo digital correction. For this reason, the correlation with the indicated values must also be taken into consideration when a strict relationship between the analog output voltage and luminance is required.

(unit: cd/m<sup>2</sup>)

		Measuring Field				
		3°	2°	1°	0.2°	0.1°
Range 1	Max. Luminance	0.15	0.3	1.2	30	120
	Luminance per 1 mV	0.00005	0.0001	0.0004	0.01	0.04
Range 2	Max. Luminance	1.5	3	12	300	1 200
	Luminance per 1 mV	0.0005	0.001	0.004	0.1	0.4
Range 3	Max. Luminance	15	30	120	3 000	12 000
	Luminance per 1 mV	0.005	0.01	0.04	1	4
Range 4	Max. Luminance	150	300	1 200	30 000	120 000
	Luminance per 1 mV	0.05	0.1	0.4	10	40
Range 5	Max. Luminance	1 500	3 000	12 000	3 00 000	1 200 000
	Luminance per 1 mV	0.5	1	4	100	400

#### \* Request

- The analog output voltage depends on the machining precision of the aperture mirror and the characteristics of the photo detector. When the luminance value is to be calculated from the output voltage value, take the correlation with the indicated values into consideration.

#### Memo

- The relationship between the analog output voltage of tristimulus value X<sub>2</sub>, Z and tristimulus values is the same as those in the table above. Note, however, that the unit is not luminance cd/m<sup>2</sup>. No unit is used.
- The instrument is provided with analog output adjustment controls for offset and gain. Use these controls selectively according to specific application. The maximum value of the analog output voltage is 4V. Please do not exceed the maximum voltage.

### ■ Analog output response speed

The analog output response speed differs depending on the measurement range used.

Response speed "Appendix: Analog Output Response Speed"

To observe the characteristics of a flashing light source, set the analog output response speed in the function mode to FAST. When the speed is set to NORMAL, the integral capacitor value is increased and operation undergoes smoothing, so the response speed becomes slow.

Function mode "3.2.11 Selecting the Analog Output Response Speed"

### ■ How to use analog output

The following describes the procedure for observing analog output.

- 1 Solder and attach the shielded wire of the core to the analog output plug (supplied), and connect it to the device.

Memo

- The pin side of the plug is the signal.

- 2 Set the measurement range, measurement method, tristimulus value filter, and analog output response speed in the function mode.

Function mode "3.2.8 Setting the Measurement Range"

Function mode "3.2.9 Setting the Measurement Mode"

Function mode "3.2.10 Selecting the Filter of the Tristimulus Value Fixed Mode"

Function mode "3.2.11 Selecting the Analog Output Response Speed"

- 3 Press the [RUN/HOLD] switch to start measurement.

Memo

- Analog output can also be observed in a [HOLD] state.

\*  
Request

- Correct measurement cannot be performed when this feature is used with output voltage in a saturated state. Be sure to set the proper measurement range.
- The output impedance is about 100Ω. Use a recorder having an input impedance of 10kΩ or more.

# 3. Various Settings

## 3.1 Function Mode

The function mode is for checking or changing various data or settings that are stored in the instrument's memory.

### 3.1.1 Entering/Returning from Function Mode

Entering and returning from the function mode is performed using the [FUNCTION] button. Press the button once, to enter Function mode, and press it again to return from Function mode.

#### ■ Entering the function mode

- 1 Check that the instrument is in the waiting state (HOLD state).
- 2 Hold down the [FUNCTION] switch for about 2 seconds to enter the function mode.  
Kinds of displayed data  「3.1.2 Data/Setting Item Display」

#### ■ Returning to the measurement mode

Press the [FUNCTION] switch.

The function mode is exited, and the measurement mode screen is displayed.

 Memo

- When returning to the measurement mode, there is no need to hold down the [FUNCTION] switch.















## 3.1.2 Displaying Data/Setting Items

In the function mode, each press of the [ENTER] button changes the type of data/setting item that is displayed. Press the [ENTER] button until the data/setting item to be checked or changed is displayed.

The displayed data/setting items are as follows.

### Memo

- The standard sample and white board are not displayed when they are not to be measured.

- Selecting light source/object color  "3.2.1 Setting Measurement of Object Color"
- Selecting measurement of absolute values/difference  "3.2.2 Measuring Difference"
- Setting the averaging count  "3.2.3 Setting the Averaging Count"
- Setting the correction factor  "3.2.4 Correction Factor"
- Setting the area correction factor  "3.2.5 Area Correction Factor"
- Selecting the interface  "3.2.6 Selecting the Interface"
- Selecting RS-232C communication parameters  "3.2.7 RS-232C Parameters"
- Selecting AUTO range/manual range  "3.2.8 Measurement Ranges"
- Selecting chromaticity/luminance/analog observation  "3.2.9 Setting the Measurement Mode"
- Selecting the filter  "3.2.10 Selecting the Tristimulus value Filter"
- Selecting analog output response speed  "3.2.11 Selecting Analog Output Response Speed"
- Buzzer sound  "3.2.12 Buzzer Sound"
- Communication format  "3.2.13 Communication Format"
- Color adjustment  "3.2.14 Color Adjustment"
- Range retry count  "3.2.15 Range retry count"

### 3.1.3 Display Screens

The follows shows and describes the screens that are displayed in the function mode.

Pressing the [ENTER] button displays the next screen.

For details on each screen, see the details "x.x OOOO".

■ **Selecting light source/object color**

Select light source color "SOURCE" or object color "OBJECT".

Details "3.2.1.1 Setting Light Source/Object Color"

```
* SOURCE / OBJECT *
SOURCE
```

■ **Selecting measurement of absolute values/difference**  
Select measurement of absolute values "ABSOLUTE" or difference "DIFFERENT".

Details "3.2.2 Selecting Measurement of Absolute Values/Difference"

```
* ABS / DIF *
ABSOLUTE
```

■ **Setting the averaging count**

Sets the averaging count in the averaging measurement mode.

Select the averaging count from 2 / 3 / 5 / 10.

Details "3.2.3 Setting the Averaging Count"

```
* AVERAGE MEASURE *
AVERAGE 3
```

■ **Selecting the correction type**

Select normal correction or direct correction.

Details "3.2.4 Correction Factor"

```
* FACTOR A / B *
FACTOR A
```

■ **Setting the correction factor**

Set the correction factor to be used for individual correction.

Details "3.2.4 Correction Factor"

```
* FACTOR NUMBER *
SET FACTOR OFF
```

■ **Setting the area correction factor**

Set the correction factor to be used for area correction.

Details "3.2.5 Area Correction Factor"

```
* FACTOR GROUP *
OFF
```

■ **Selecting the interface**

Select the interface to be used for communicating with the PC from RS-232C or USB.

Details "3.2.6 Selecting the Interface"

```
* INTERFACE *
RS-232C
```

■ **Setting the RS-232C parameters**

Set the RS-232C interface.

Details "3.2.7 RS-232C Parameters"

```
*RS-232C PARAMETERS*
BAUD RATE=38400
LENGTH=7 PARITY=ODD
STOP BITS=1
```

### 3. Various Settings

- **Selecting the measurement range**  
Select the AUTO range AUTO/manual range MANUAL.  
Details ↗ "3.2.8 Measurement Range"

```
*  AUTO / MANUAL  *  
  
AUTO
```

- **Selecting the measurement range for the manual range**  
Set the measurement range for when manual range is selected.  
RANGE1 / 2 / 3 / 4 / 5 / EACH SELECT  
Details ↗ "3.2.8.1 Setting the Manual Range"

```
*  MANUAL RANGE  *  
  
ALL RANGE 3
```

- **Setting the measurement mode**  
Set luminance chromaticity CHROMATICITY/luminance LUMINANCE ONLY/analog observation LUMI-ANA.USE.  
Details ↗ "3.2.9 Setting the Measurement Mode"

```
*  CHROMA / LUMI  *  
  
CHROMATICITY
```

- **Selecting the filter for the tristimulus value fixed mode**  
Select the tristimulus value filter X<sub>2</sub> / Y / Z for when luminance and analog observation is selected.  
Details ↗ "3.2.10 Selecting Filters in the Tristimulus Value Fixed Mode"

```
*  FILTER SELECT  *  
  
Y FILTER
```

- **Selecting the analog output response speed**  
This item is used to observe the flashing state of a light source.  
The response speed of the photo-receiver circuit is switched.  
Details ↗ "3.2.1 Selecting the Analog Output Response Speed"

```
*  ANALOG RESPONSE  *  
  
NORMAL
```

- **Setting the buzzer sound**  
Set the buzzer sound ON/OFF.  
Details ↗ "3.2.12 Buzzer Sound"

```
*  BUZZER ON/OFF  *  
  
O N
```

- **Selecting the communication format**  
Select the communication format from BM-5AC/BM-5A.  
Details ↗ "3.2.13 Communication Format"

```
*  COMM DATA FORMAT  *  
  
BM-5AC
```

- **Setting the color adjustment**  
Use this when measurement is done on condition that priority is given to the correlativity with the old models.  
Details ↗ "3.2.14 Color Adjustment "

```
COLOR ADJUSTMENT  
  
O N
```

- **Selecting the range retry count**  
Set the maximum retry count when extracting a range.  
Details ↗ "3.2.15 Range retry count "

```
RANGE RETRY  
  
MAXIMUM 3
```

**Screens in the object color mode**

The following are displayed as sub-screens when object color OBJECT is selected in the main screen in the function mode.

■ **Setting the luminance factor of the white board**

Display the luminance factor of the white board used for measurement of light sources.

Enter the luminance factor of the white board to be used when luminance factor differs with the indicated values.

* WHITE BOARD LUMINANCE FACTOR 100.0%
---

■ **White board correction factor 1**

Display correction factors KX, KY, KZ for measuring white boards.

W	KX= 2.469E+00
	KY= 2.424E+00
	KZ= 4.216E+00
	S=PAGE

■ **White board correction factor 2**

Display the luminance chromaticity entered values of the light source for when the correction factors for measuring white boards is calculated by measurement.

W	x= 0.3101
REF	y= 0.3162
	L= 5.000E+01
	S=PAGE

■ **White board correction factor 3**

Display the values measured by white board correction factor 2 above.

W	x= 0.3644
SMP	y= 0.3784
	L= 2.063E+01
	S=PAGE

### 3.1.4 Entering Numerical Values

The following describes the procedure for entering numerical values, for example, when setting the luminance factor of the white board, or when entering luminance chromaticity as the reference data for correction factors.

The procedure for entering numerical values in the function mode is the same for all setting items. The following describes an example of how to set numerical values in the function mode when setting the luminance factor of the white board.

**White board luminance factor setting screen**

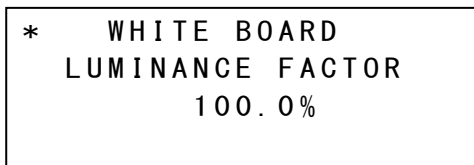

- 1 Press the [CHANGE] button. The cursor flashes at the entry location.



- 2 Press the [ROTATION] button and select the value to enter. Each press switches the display as follows:
   
→ 0 → 1 → 2 → 3 → 4 → 5 → 6 → 7 → 8 → 9 → + → - → E → . . . . .

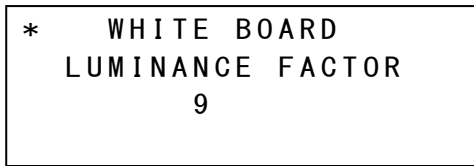

- 3 Press the [SHIFT] button to move the cursor to the next digit.



- 4 Repeat steps 2 and 3 to enter the numerical value.
  
- 5 When you have finished entering the final digit, press the [ENTER] button to apply the entry.

 Memo

· If you make a mistake during entry, perform step 5 and repeat the procedure from step 1.

## 3.2 Detailed Explanation of Function Mode

### 3.2.1 Selecting Light Source/Object Color

The light source color and object color can be switched according to the measurement target.

```
* SOURCE / OBJECT *
SOURCE
```

Display method  "3.1.2 Displaying Data/Setting Items"

- 1 Press the [CHANGE] button.
- 2 Press the [ROTATION] button and select the setting.  
Each press switches the display as follows:  
SOURCE → OBJECT .....
- 3 After you have selected the setting, press the [ENTER] button.

#### 3.2.1.1 Setting Measurement of Object Color

When you select object color at light source color(SOURCE)/object color (OBJECT) in the function mode, the mode changes to the object color mode.

The procedure for measuring the object color is as follows.

- Step 1 Selecting the object color
- Step 2 Setting the luminance factor of the white board
- Step 3 Setting the correction factor for white board measurement  
\* When the correction factor does not need to be set, proceed to step 4.
- Step 4 Measuring the white board and object color

The following describes how to measure object color according to the above procedure.

#### Step1 Selecting the object color

- 1 When [RUN/HOLD] is set to HOLD in the measurement screen, press the [FUNCTION] switch to enter the function mode.
- 2 The following screen is displayed. Use the [CHANGE] or [ROTATION] switch to set to OBJECT.

```
* SOURCE / OBJECT *
SOURCE
```



```
* SOURCE / OBJECT *
OBJECT
```

- 3 Press the [ENTER] switch to apply the change.  
The white board luminance factor setting screen is displayed. ⇒ Proceed to Step 2

**Step 2 Setting the luminance factor of the white board**

- 1 The following white board luminance factor setting screen is displayed. Use the [CHANGE], [ROTATION] or [SHIFT] switch to set the luminance factor. The luminance factor can be input from 80% to 120%.

Entering numerical values  "3.1.4 Entering Numerical Values"

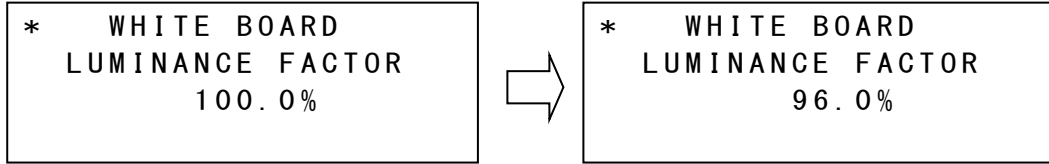

- 2 Press the [ENTER] switch to apply the change. The white board measurement correction factor is displayed. ⇒ Proceed to Step 3

### Step 3 Setting the luminance factor of white board measurement

When the chromaticity  $xy$  of the illumination light source used when measuring object color is already known, object color can be measured more accurately by applying correction to the measurement results of the white board (illumination light source).

Correction can be performed by the following two ways.

- ① Directly enter the correction factors of the tristimulus values.  
Instructions marked by ① in the figure below.
- ② After the luminance chromaticity is entered, perform measurement to automatically calculate the correction factor. Instructions marked by ② in the figure below.

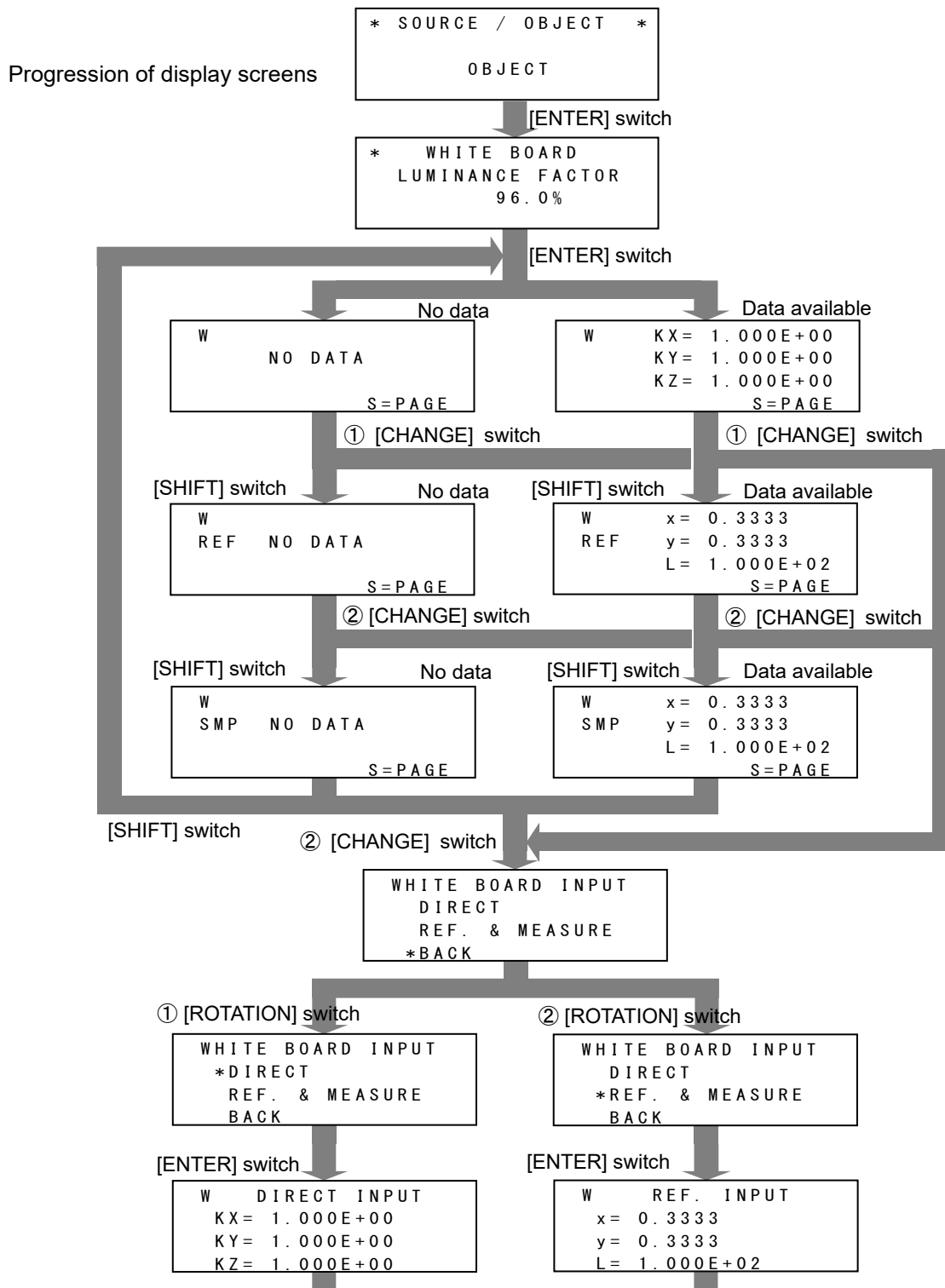

Change the numerical values by the [CHANGE] [ROTATION] [SHIFT] [ENTER] switches.

### 3. Various Settings

Change the luminance factor of the white board, set the correction factor in white board measurement, and apply the changes by the [ENTER] switch. The following message is displayed.

Place the white board under the illumination light source for measuring the object color, and press the [RUN/HOLD] switch to measure white board.

<p style="text-align: center;">Attention!!</p> <p>Please set the Ref. sample, then push RUN/HOLD key.</p>
---

#### **Measuring the object color**

When white board measurement ends, the continuous measurement mode is entered, and the object color can be measured.

## 3.2.2 Selecting Measurement of Absolute Values/Difference

With this instrument, it is possible to measure absolute values and the difference from reference data.

```
*   ABS / DIF   *
      DIFFERENCE
```

ABSOLUTE : Absolute value measurement

DIFFERENCE : Difference measurement

Display method  "3.1.2 Displaying Data/Setting Items"

- 1 Press the [CHANGE] button.
- 2 Press the [ROTATION] button and select the setting.  
Each press switches the display as follows:  
ABSOLUTE → DIFFERENCE .....
- 3 After you have selected the setting, press the [ENTER] button.

### 3.2.2.1 Measuring Difference

When you select difference measurement (DIFFERENCE) as absolute value measurement / difference measurement in the function mode, the difference with the standard sample can be measured. Set the standard difference by the following procedure.

- 1 Display the absolute value measurement/difference measurement screen, select difference measurement (DIFFERENCE), and apply the settings by [ENTER].

```
*   ABS / DIF   *
      DIFFERENCE
```

- 2 The following screen is displayed.  
Place the standard sample, and press the [RUN/HOLD] switch to measure it.

```
Attention!!
Please set
the Std. sample, then
push RUN/HOLD key.
```

- 3 The [Measuring] screen is displayed to indicate that measurement is being performed, and then the measurement results are displayed.

[Measuring] screen

```
Measuring
```

Measurement results display

```
* STANDARD SAMPLE *
      x= 0.3127
      y= 0.3290
L= 1.000E+02 cd/m^2
```

- 4 The following function mode screen is displayed. Press the [FUNCTION] switch to return to the measurement mode.
- 5 Press the [RUN/HOLD] switch to start measurement.

```
F2.0 DIF K00 G00-0
      x= 0.0183
      y= 0.0227
L=-1.121E+01 cd/m^2
```

 Memo

- The absolute value measurement/difference measurement setting is held in memory even if the instrument is turned OFF.
- The standard sample data is cleared from memory by turning the power OFF then back ON again.
- To check the standard sample stored to memory, press the [ENTER] switch in the screen in Step 1.

### 3.2.3 Setting the Averaging Count

Averaging measurement is performed by selecting [AVE.(AVERAGE)] on the [SINGLE/AVE.] panel switch. In this section, select the number of averaging measurements.

The averaging count can be selected from 2 times/3 times/5 times/10 times.

Display method  "3.1.2 Displaying Data/Setting Items"

Selecting the [SINGLE/AVE.] panel switch  "1.2 Part Names and Functions"

```
* AVERAGE MEASURE *
      AVERAGE 5
```

- 1 Press the [CHANGE] button.
- 2 Press the [ROTATION] button and select the setting.  
Each press switches the display as follows:  
2 => 3 => 5 => 10 => 2 .....
- 3 **After you have selected the setting, press the [ENTER] button.**

## 3.2.4 Correction Factor

Measurement results can be corrected by applying the correction factor on the measurement result. "Correction factor" is a function for correcting measurement results according to an internal program.

Correction factors can be registered in the following 3 ways:

- 1 By directly entering KX, KY, KZ
- 2 By entering luminance chromaticity and performing measurement to obtain KX, KY, KZ
- 3 By connecting to another instrument and comparing measurement results to obtain KX, KY, KZ(direct correction)

Measurement results are corrected according to the following formula:

$$X' = X \times KX$$

$$Y' = Y \times KY$$

$$Z' = Z \times KZ$$

where, X',Y',Z' : Tristimulus values after correction  
 X,Y,Z : Tristimulus values obtained by measurement  
 KX,KY,KZ : Correction factor for tristimulus values

Display the following screen in the function mode.

```

*   FACTOR A / B   *
*
*   FACTOR A
  
```

Display method  "3.1.2 Displaying Data/Setting Items"

Select the correction factor group from FACTOR A/B.

**FACTOR A** : The correction factors obtained by direct entry of correction factors KX, KY, KZ above or by entry and measurement of luminance chromaticity are stored in this group.

Up to 10 correction factors can be stored in this group.

**FACTOR B** : The correction factors obtained by direct correction are stored in this group.

Up to 5 correction factors can be stored in this group.

### 3.2.4.1 Correction Factor Menu Screen

■When FACTOR A is selected

The next screen is the menu screen that is displayed when the correction factor group FACTOR A is selected.



The contents of this screen are as follows:

- DISP&SET : Select this item to check the values of the correction factors (K01 to K10) or to set the number of the correction factor to be used. "3.2.4.3 Checking/Setting Correction Factors"
- INPUT : Select this item to enter or change the correction factor. "3.2.4.2 Entering Correction Factors"
- CLEAR : Select this item to clear the correction factor. "3.2.4.4 Clearing Correction Factors"
- OFF : Select this item to disable correction factors.
- BACK : Select this item to return to the previous screen.

Pressing the [ROTATION] switch moves the menu selection cursor "\*" .  
 Pressing the [ENTER] switch applies the selected menu item and displays the next processing screen.

The following describes the procedure for displaying this screen.

- 1 Display the following screen in the function mode.

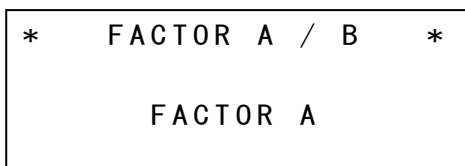

- 2 Check that FACTOR A is selected, and press the [ENTER] switch. The following screen is displayed.

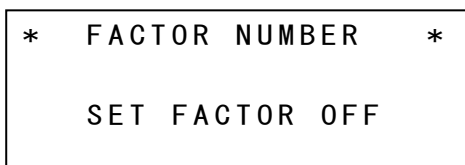

- 3 Press the [CHANGE] switch. The menu screen is displayed.



Entering numerical values for correction factors "3.2.4.2 Entering Correction Factors"



### 3.2.4.2 Entering Correction Factors

The following describes the procedure for entering the correction factor.

- 1 Display the following screen in the function mode.

```
*   FACTOR A / B   *  
  
    FACTOR A
```

- 2 Check that FACTOR A is selected, and press the [ENTER] switch. The following screen is displayed.

```
*   FACTOR NUMBER   *  
  
    SET FACTOR OFF
```

- 3 Press the [CHANGE] switch. The menu screen is displayed.

```
FACTOR  
DISP&SET      OFF  
INPUT         *BACK  
CLEAR
```

- 4 Press the [ROTATION] switch to move the selection cursor "\*" to "INPUT".

```
FACTOR  
DISP&SET      OFF  
*INPUT        BACK  
CLEAR
```

- 5 Press the [ENTER] button to display the correction factor screen.

```
K01  
  
    NO DATA  
  
    R=NEXT S=PAGE
```

Press the [ROTATION] switch to display the correction factor entry screen. In this example, enter correction factor number 01.

- 6 Press the [CHANGE] switch to display the correction factor entry menu screen.

```

FACTOR INPUT
  DIRECT
  REF. & MEASURE
  *BACK

```

The correction factor can be entered by the following ways:

**DIRECT**

Select this item to directly enter tristimulus value correction factors KX, KY, KZ.

 "Direct Entry"

**REF. & MEASURE**

Select this item to enter target luminance and chromaticity data to calculate the correction factors based on measurement by that data.

 "Calculation from Measurement"

**BACK**

Select this item to return to the previous screen.

■ **Directly entering tristimulus value correction factors KX, KY, KZ**

- 1 Press the [ROTATION] switch to move the selection cursor "\*" to "DIRECT".

```

FACTOR INPUT
 *DIRECT
  REF. & MEASURE
  BACK

```

- 2 The correction factor entry screen is displayed.

```

K01 DIRECT INPUT
  KX= 1.000E+00
  KY= 1.000E+00
  KZ= 1.000E+00

```

- 3 Press the [CHANGE] switch and enter the correction factor.

Entering numerical values  "3.1.4 Entering Numerical Values"

The following describes the procedure for directly entering the correction factor.

- ① Press the [CHANGE] switch to enable entry of the value for KX. Enter the numerical value using the [ROTATION] or [SHIFT] switch.
- ② When you have finished entering KX, press the [ENTER] button. KY can now be entered. Set the values for KY and KZ in the same way.

■ **Entering target luminance and chromaticity data to calculate the correction factors based on measurement by that data**

- 1 Press the [ROTATION] switch to move the selection cursor "\*" to "REF.&MEASURE", and then apply the setting with the [ENTER] switch.

```

FACTOR INPUT
  DIRECT
 *REF. & MEASURE
  BACK
    
```

- 2 The correction factor entry screen is displayed.

```

K01 DIRECT INPUT
  x= *****
  y= *****
  L= *****
    
```

- 3 Press the [CHANGE] switch, and enter the target luminance and chromaticity data.
 

Entering numerical values  "3.1.4 Entering Numerical Values"

The following describes the procedure for entering the luminance chromaticity.

- ① Press the [CHANGE] switch to enable entry of the value for chromaticity x. Enter the numerical value using the [ROTATION] or [SHIFT] switch.
  - ② When you have finished entering chromaticity x, press the [ENTER] button. Chromaticity y can now be entered. Set the values for chromaticity y and luminance L in the same way.
- 4 After entering chromaticity x, y and luminance L, press the [ENTER] switch to apply the entered values. Press the [ENTER] switch again. The next screen is displayed. Collimate the sample, and press the [RUN/HOLD] switch to measure it.

```

      Attention!!
Please set
the Ref. sample, then
push RUN/HOLD key.
    
```

- 5 When measurement ends, the calculated correction factor is displayed, followed by the correction factor entry menu screen.
 

Calculated correction factor

```

K01  KX= 1.005E+00
      KY= 1.002E+00
      KZ= 9.952E-01
      R=NEXT S=PAGE
    
```

Correction factor entry menu screen

```

FACTOR INPUT
  DIRECT
 *REF. & MEASURE
  BACK
    
```

- 6 Press the [ROTATION] switch to move the selection cursor "\*" to "BACK". Then apply pressing the [ENTER] switch to apply the setting, and return to the correction factor display screen.

```

K01  KX= 1.005E+00
      KY= 1.002E+00
      KZ= 9.952E-01
      R=NEXT S=PAGE

```

- 7 Press the [SHIFT] switch (S=PAGE) to confirm the correction factor.  
Tristimulus value correction factors KX, KY, KZ

```

K01  KX= 1.005E+00
      KY= 1.002E+00
      KZ= 9.952E-01
      R=NEXT S=PAGE

```

Target luminance/chromaticity entry values

```

REF01  x= 0.4476
        y= 0.4074
        L= 1.000E+02
        R=NEXT S=PAGE

```

Result of sample measurement

```

SMP01  x= 0.4464
        y= 0.4075
        L= 9.980E+01
        R=NEXT S=PAGE

```

- 8 Press the [ENTER] switch to return to the correction factor menu screen.

### 3.2.4.3 Checking/Setting Correction Factors

The values of the currently registered correction factors are displayed. If there are no correction factors registered, "NO DATA" is displayed. "SET" is displayed underneath the number of the correction factor currently being used.

When no correction factors are registered

```

K 0 1
      NO DATA
      R=NEXT S=PAGE
    
```

When correction factors are registered

```

K 0 1  KX= 1.000E+00
      KY= 1.000E+00
      KZ= 1.000E+00
C=SET R=NEXT S=PAGE
    
```

When use of correction factors is selected

```

K 0 1  KX= 1.000E+00
SET    KY= 1.000E+00
      KZ= 1.000E+00
C=SET R=NEXT S=PAGE
    
```

Press the [CHANGE] switch sets (cancels) correction factors.

The contents of this screen are as follows:

- K01                    Correction factor number Up to 10 (K01 to K10) correction factors can be registered.
- NO DATA            This is displayed when no correction factors are registered.
- KX=..., KY=..., KZ=...  
Correction factor for tristimulus values
- C=SET                [CHANGE] switch = SET  
Sets the displayed correction factor as the correction factor to be used.  
When the correction factor is set, "SET" is displayed underneath the correction factor number
- R=NEXT               [ROTATION] switch =NEXT  
Displays the correction factor for the next number
- S=PAGE               [SHIFT] switch =PAGE  
Each press switches the display as follows:  
Reference data → Sample data → Correction factor data → Reference data  
→ . . .

**- Reference Data -**

The reference data that was entered for calculating the correction factor is displayed.

```
REF01  x= 0.4476
        y= 0.4074
        L= 1.000E+02
C=SET  R=NEXT  S=PAGE
```

**- Sample Data -**

The result of sample measurement after the correction factor was calculated is displayed.

```
SMP01  x= 0.4476
        y= 0.4074
        L= 1.000E+02
C=SET  R=NEXT  S=PAGE
```

Calculating the correction factor  "3.2.4.2 Entering Correction Factors"

Press the [ENTER] switch, then return to the previous screen.

 **Memo**

- Numbers such as "REF01" and "SMP01" that are displayed at the top left of the reference data screen and sample data screen correspond to the correction factor numbers. In other words, when the correction factor for K01 is calculated, the reference data for K01 is REF01 and the sample data for K01 is SMP01.

### 3.2.4.4 Clearing Correction Factors

- 1 Display the correction factor menu screen.

```

FACTOR
DISP&SET      OFF
INPUT         *BACK
CLEAR
    
```

- 2 Press the [ROTATION] switch to move the selection cursor "\*" to "CLEAR", and then apply the setting with the [ENTER] switch.

```

FACTOR
DISP&SET      OFF
INPUT         BACK
*CLEAR
    
```

- 3 The following screen is displayed.

```

FACTOR CLEAR
ALL&CLEAR
SELECT CLEAR
*BACK
    
```

Press the [ROTATION] switch to move the selection cursor "\*" to select the desired item.

ALL CLEAR : Select this item to clear all correction factors.

SELECT CLEAR : Select this item to clear selected correction factor Nos.

#### ■ When "ALL CLEAR" is selected

```

FACTOR CLEAR
ALL FACTOR CLEAR
YES
*BACK
    
```

YES : Clears all registered correction factors.

BACK : Returns to the previous screen.

#### ■ When "SELECT CLEAR" is selected

```

CL01 KX= 1.000E+00
SET KY= 1.000E+00
      KZ= 1.000E+00
C=DEL R=NEXT S=PAGE
    
```

[CHANGE] switch C=DEL : Clears the currently displayed data.

[ROTATION] switch R=NEXT : Displays the data for the next number

[SHIFT] switch S=PAGE : Each press switches the display as follows:  
 Correction factor data → Reference data →  
 Correction factor data ...

[ENTER] switch : Returns to the previous screen.

### 3.2.5 Area Correction Factor

"Area correction factor" is a function for correcting measurement results that fall within an arbitrary area when that area is specified on the xy and u'v' chromaticity diagrams.

 Memo

- There are two ways of registering area correction factors, by using the CS-900A application software (sold separately) or by making a communication program by referring to the list of communication commands.

List of commands  "4. Communication with a PC"

The number of the currently set area correction factor group is displayed.

Display method  "3.1.2 Displaying Data/Setting Items"

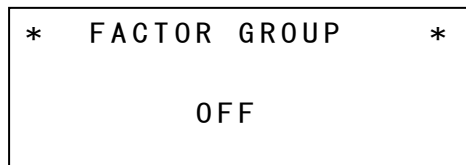

Up to 10 area correction factor groups can be set for the instrument.

Groups 1 to 5 are the area correction factors for the xy chromaticity diagram, and groups 6 to 10 are the area correction factors of the u'v' chromaticity diagram.

Also, 5 chromaticity areas can be set to 1 group.

When setting chromaticity areas, register the minimum and maximum values of chromaticity xy (or u'v'), the minimum value of luminance L, and correction factors .

Area correction groups

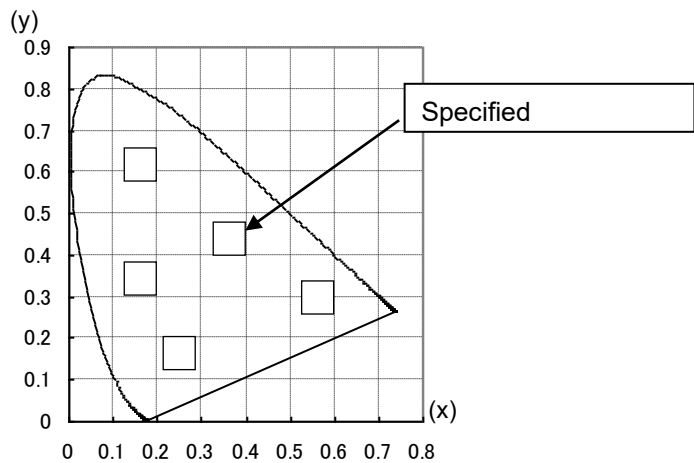
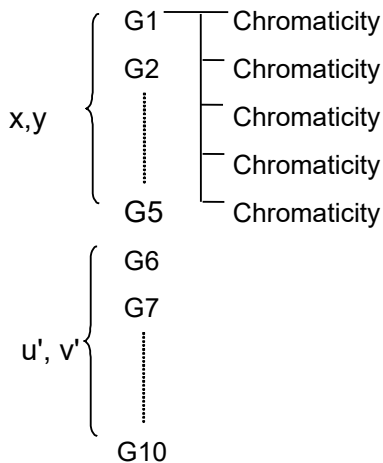

### 3. Various Settings

For example, to perform measurement with different correction factors applied on each color of R (red), G (green), B (blue), and W (white), correction factors for each individual color can be applied by specifying the chromaticity colors of R (red), G (green), B (blue), and W (white).

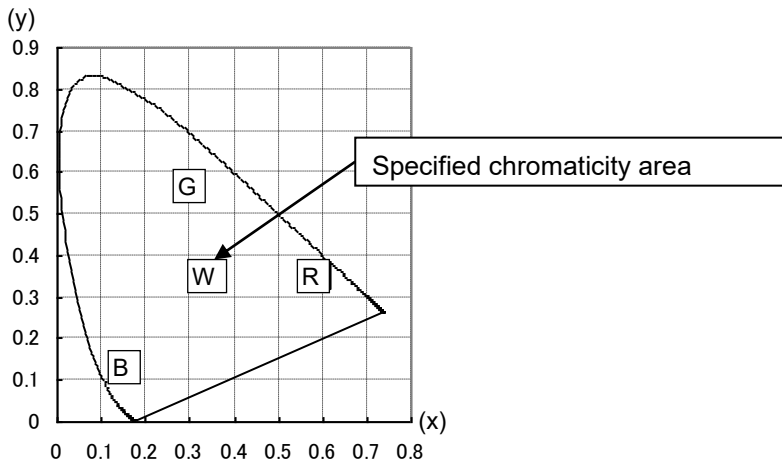

 <b>Request</b>	<ul style="list-style-type: none"> <li>· A slight error may occur in the range of the chromaticity area since chromaticity is set based on actual measurement results. The range of the chromaticity area should be set with a certain degree of margin depending on the situation.</li> </ul>
---	--

The following describes the method for specifying a chromaticity area.

xy chromaticity diagram : Specify the minimum and maximum xy values of the chromaticity area, the minimum L luminance value, and the area to which the correction factor is applied.

u'v' chromaticity diagram: Specify the minimum and maximum u'v' values of the chromaticity area, the minimum L luminance value, and the area to which the correction factor is applied.

 <b>Request</b>	<ul style="list-style-type: none"> <li>· The chromaticity area should be specified so that the difference between the minimum and maximum values is 0.03 or less.</li> </ul>
---	--

### 3.2.5.1 Setting the Area Correction Factor Group

The following describes the procedure for changing the area correction factor group setting.

- 1 Display the following screen in the function mode.

```
*  FACTOR GROUP  *  
  
      OFF
```

- 2 Press the [CHANGE] switch.  
The currently set area correction group is displayed.

```
*  GROUP SET    *  
  
      GROUP  *OFF
```

- 3 Press the [ROTATION] switch to select the area correction group.

```
*  GROUP SET    *  
  
      GROUP    1
```

- 4 After you have selected the setting, press the [ENTER] button.

### 3.2.5.2 Displaying the Area Correction Factor

The following describes the procedure for displaying the chromaticity area currently set for an area correction factor group.

- 1 Press the [CHANGE] switch.  
The currently set area correction group is displayed.

```

*   GROUP SET   *
      GROUP   1
    
```

- 2 Press the [ROTATION] switch, and select the area correction factor group whose chromaticity area is to be displayed.
- 3 Press the [CHANGE] switch.  
The data of the currently set chromaticity area is displayed.

```

G1-1   x0.2000-0.2300
  SET   y0.3000-0.3300
        L1.000E+02
C=SET  R=NEXT  S=PAGE
    
```

- [CHANGE] : Sets the displayed chromaticity area.  
When set, "SET" is displayed underneath the chromaticity area number
- [ROTATION] : Displays the chromaticity area of the next number
- [SHIFT] : Each press switches the display as follows:  
Correction factor data → Chromaticity area data → Correction factor data ...
- [ENTER] : Returns to the previous screen.

## 3.2.6 Selecting the Interface

This instrument supports two interfaces, RS-232C and USB, as the communication interface with the PC.

Select which of these interfaces is to be used for communications.

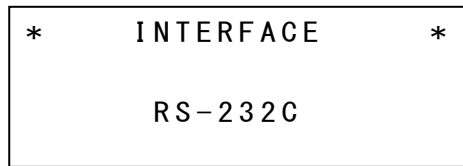

Display method "3.1.2 Displaying Data/Setting Items"

The following describes the procedure for changing the interfaces setting.

- 1 Press the [CHANGE] switch.
- 2 Press the [ROTATION] button and select the setting.
- 3 Press the [ENTER] switch to apply the change.

### Memo

- After changing the interface setting, be sure to reset the instrument.(the power OFF then back ON again)

Turning the Power ON/OFF "1.3 Preparation"

## 3.2.7 RS-232C Parameters

Set the RS-232C interface communication parameters.

```
*RS-232C PARAMETERS*  
BAUD RATE=38400  
LENGTH=7 PARITY=ODD  
STOP BITS=1
```

Display method  "3.1.2 Displaying Data/Setting Items"

The following describes the procedure for changing the RS-232C interface communication parameters setting.

- 1 Press the [CHANGE] switch.  
The cursor flashes at the numerical value digit at [BAUD RATE], indicating that the value can be changed.
- 2 Press the [ROTATION] switch and select the setting.  
Each press switches the display as follows:  
BAUD RATE (communication speed) : 38400→2400→4800→9600→19200→38400...  
LENGTH (data length) : 7→8→7...  
PARITY (parity bit) : ODD→NONE→EVEN→ODD...  
STOP BIT (stop bit) : 1→2→1...

 Memo

- When there are no contents to be changed, press the [SHIFT] switch, and move the cursor to the next parameter.

- 3 After you have selected the setting, press the [SHIFT] switch.  
The cursor moves to the next parameter.
- 4 Repeat steps 2 and 3.
- 5 When setting all items is ended, [ENTER] switch is pushed. The changed content is memorized in the BM-5AC.

## 3.2.8 Measurement Range

The measurement range of this instrument can be switched according to the luminance of the light source used for measurement.

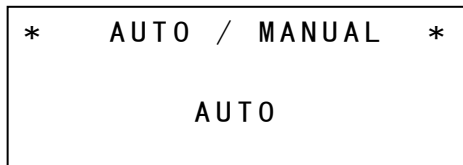

**AUTO** : Performs measurement using the optimum range matched to the luminance.

**MANUAL**: Performs measurement by a fixed range.

Display method "3.1.2 Displaying Data/Setting Items"

The following describes the procedure for changing the measurement range setting.

- 1 Press the [CHANGE] button.
- 2 Press the [ROTATION] button and select the setting.  
Each press switches the AUTO/MANUAL setting.
- 3 After you have selected the setting, press the [ENTER] button.

### 3.2.8.1 Setting the Manual Range

- 1 Display the following screen in the function mode. The current setting is displayed.

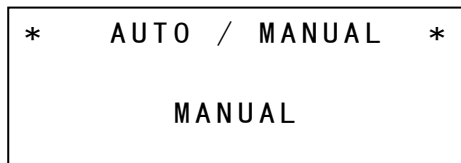

- 2 Set to "MANUAL" using the [CHANGE] or [ROTATION] switch.
- 3 Press the [SHIFT] switch. The following screen is displayed.

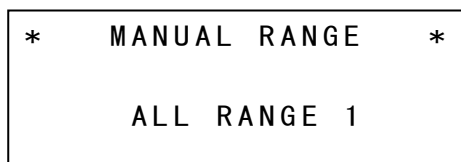

- 4 Each press of the [ROTATION] switch switches the setting range.
  - ALL RANGE1 to 5 : Sets the ranges of tristimulus values X2, Y and Z to the same range.
  - EACH SELECT : Sets the ranges of tristimulus values X2, Y and Z to individual ranges.
- 5 The procedure for setting the ranges of tristimulus values X2, Y and Z to individual ranges is as follows.  
Press the [CHANGE] switch with "EACH SELECT" displayed.

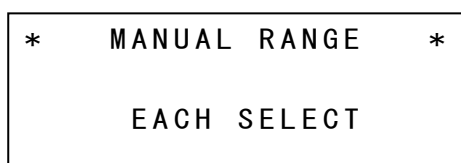

### 3. Various Settings

- 6** When the following screen is displayed, set each range using the [CHANGE] or [ROTATION] switch. After setting the ranges, press the [SHIFT] switch. The cursor moves to the next range.



*      MANUAL R (EACH) *
X2    RANGE 3
Y     RANGE 3
Z     RANGE 3

- 7** Press the [ENTER] switch. The mode returns to the function mode, and the settings are enabled.

#### Memo

- When the [NORMAL/FINE] switch is set on the NORMAL side, setting tristimulus values common range mode becomes effective in the place where the manual mode is measured.
- When the [NORMAL/FINE] switch is set on the FINE side, setting tristimulus values individual range mode becomes effective in the place where the manual mode is measured.

[NORMAL/FINE] switch  "1.2 Part Names and Functions ■ Panel switches"

Entering the function mode  "3.1.1 Entering/Returning from the Function Mode"  
Entering numerical values  "3.1.4 Entering Numerical Values"

## 3.2.9 Setting the Measurement Mode

The measurement mode is selected from the chromaticity measurement mode, the luminance measurement mode, and the analog response observation mode.

Display method  "3.1.2 Displaying Data/Setting Items"

Selecting analog observation  "3.2.11 Selecting the Analog Output Response Speed"

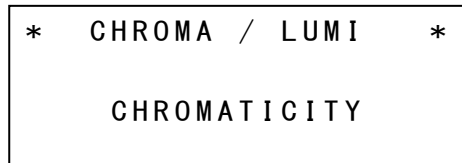

CHROMATICITY	: Chromaticity measurement
LUMINANCE ONLY	: Luminance measurement
LUMI-ANA USE	: Fixed filter (for analog response observation)

The following describes the procedure for changing the measurement mode setting.

- 1 Press the [CHANGE] button.
- 2 Press the [ROTATION] button and select the setting.  
Each press switches the display as follows:  
CHROMATICITY → LUMINANCE ONLY → LUMI-ANA USE .....
- 3 After you have selected the setting, press the [ENTER] button.

### Memo

- When luminance measurement (LUMINANCE ONLY) is selected, measurement is performed only on the tristimulus values set at "selecting the filter for the tristimulus value fixed mode" in the function mode. During this measurement, offset measurement is performed each time, and values obtained after subtraction of offset values are displayed.
- When fixed filter (LUMI-ANA USE) is selected, measurement is fixed at the filter of the tristimulus values set at "selecting the filter for the tristimulus value fixed mode" in the function mode. Offset measurement is not performed when this mode is selected. Use this mode when performing analog observation using the analog output connector.

 "3.2.10 Selecting Filters in the Tristimulus Value Fixed Mode"

## 3.2.10 Selecting Filters in the Tristimulus Value Fixed Mode

---

Select the tristimulus value filter X<sub>2</sub>/Y/Z when continuously measuring luminance or tristimulus values, or observing the flashing state of a light source using the analog output connector.

Display method  "3.1.2 Displaying Data/Setting Items"

Selecting luminance and analog observation  "3.2.9 Setting the Measurement Mode"

```
*   FILTER SELECT   *  
  
  Y   FILTER
```

The following describes the procedure for changing the tristimulus value fixed mode setting.

- 1 Press the [CHANGE] button.
- 2 Press the [ROTATION] button and select the setting.  
Each press switches the X<sub>2</sub>/Y/Z setting.
- 3 After you have selected the setting, press the [ENTER] button.

## 3.2.11 Selecting the Analog Output Response Speed (Analog Waveform Observation)

Set the analog output response speed when measuring a flashing light source using the analog output connector.  2.2.5 Using the Analog Output Connector

This setting switches the response speed of the photo-receiver circuit.

The response speed is the time required for the analog output of the instrument to reach 90% of the peak value when measuring an LED driven by a square wave from a function generator.

When the product is shipped, this setting is NORMAL. Perform general measurement with this setting at NORMAL.

**FAST** : The response speed of the photo-receiver circuit is increased.  
Set this to observe the flashing state of a display or an LED light source, for example. To observe the flashing state of a light source, connect an oscilloscope, for example, to the analog output connector on the instrument. The response speed differs depending on the measurement range (approx.5 milliseconds to 0.05 milliseconds).

**NORMAL**: The response speed of the photo-receiver circuit is decreased.  
Set this to measure luminance chromaticity or continuously measure luminance, for example, of a fixed light or a flashing light such as a high-frequency flashing light, fluorescent light, and a CRT.  
Also, use this setting when a recorder or other device is connected to the analog output connector and you are to observe light source fluctuations over a long period of time.

### Memo

- When performing analog observation using the analog output connector, make the settings at "Setting the Measurement Mode" and "Selecting Filters in the Tristimulus Value Fixed Mode."

 "3.2.9 Setting the Measurement Mode"

 "3.2.10 Selecting Filters in the Tristimulus Value Fixed Mode"

\* ANALOG RESPONSE \*

FAST

Display method  "3.1.2 Displaying Data/Setting Items"

The following describes the procedure for changing the analog output response speed setting.

- 1 Press the [CHANGE] button.
- 2 Press the [ROTATION] button and select the setting.  
Each press switches the FAST/NORMAL setting.
- 3 After you have selected the setting, press the [ENTER] button.

## 3.2.12 Buzzer Sound

Set whether or not to sound the buzzer.

Display method  "3.1.2 Displaying Data/Setting Items"

```
* BUZZER ON/OFF *  
  
O N
```

The following describes the procedure for changing the buzzer sound setting.

- 1 Press the [CHANGE] button.
- 2 Press the [ROTATION] button and select the setting.  
Each press switches the ON/OFF setting.
- 3 After you have selected the setting, press the [ENTER] button.

## 3.2.13 Communication Format

Set the communication format with the PC.

Display method  "3.1.2 Displaying Data/Setting Items"

```
* COMM DATA FORMAT *  
  
BM-5AC
```

There are two communication formats, BM-5AC and BM-5A.

### Memo

- The "BM-5A" communication format enables use of communications software prepared by the customer for use of the BM-5A on this instrument (BM-5AC). The "BM-5AC" communication format provides the user with a wider range of communication commands than the "BM-5A" communication format. We recommend the "BM-5AC" communication format when making new communications programs for the BM-5AC.
- Communication format "BM-5A" is a function that only a remote mode can be used. Please set the communication format in "BM-5AC" when you measure BM-5AC with a panel switch.

The following describes the procedure for changing the communication format setting.

- 1 Press the [CHANGE] button.
- 2 Press the [ROTATION] button and select the setting.  
Each press switches the display as follows:  
BM-5AC → BM-5A → BM-5AC .....
- 3 After you have selected the setting, press the [ENTER] button.

## 3.2.14 Color Adjustment

Use this when measurement should be done on condition that priority is given to the correlativity with the old models (BM-5A, BM-5AS).

Display method  "3.1.2 Displaying Data/Setting Items"

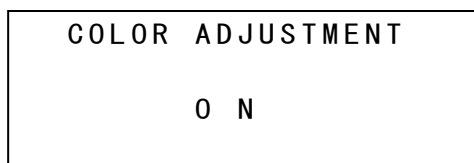

- ON : Enable the color adjustment function. (Initial setting).  
 OFF : Disable the color adjustment function.

Set this when you want to prioritize the correlation with the old model.

### Memo

- This function does not warrant the enhancement of the correlativity with the old models.
- When this function is OFF (invalid), the chromaticity accuracy is equal to the old models.

The following describes the procedure for changing the color adjustment setting.

- 1 Press the [CHANGE] switch.
- 2 Press the [ROTATION] switch and select the setting.  
Each press switches the ON/OFF setting.
- 3 After you have selected the setting, press the [ENTER] switch.

## 3.2.15 Range Retry Count

Set the range changing retry count when extracting the optimum measurement range.

For example, when the light source is fluctuated near the range changing threshold, you can shorten the measurement time.

Display method  "3.1.2 Displaying Data/Setting Items"

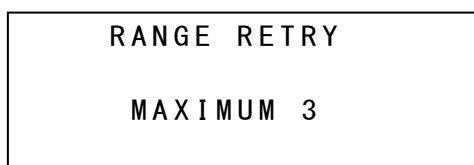

The following describes the procedure for changing the range retry count setting.

- 1 Press the [CHANGE] switch.
- 2 Press the [ROTATION] switch and select the setting.  
Each press switches the display as follows:  
1 → 2 → 3 → 4 → 5 → 1 ...
- 3 After you have selected the setting, press the [ENTER] switch.

# 4. Communication With a PC

## 4.1 Communication Commands

This instrument can communicate with a PC using the RS-232C or USB interface. There are two communication formats, the BM-5AC mode and the BM-5A mode for conventional models.

Changing the communication format  "3.13 Communication Format"

This section describes the commands available to the user for creating a communication program with the BM-5AC.

BM-5AC mode communication commands

 "4.2 BM-5AC Mode Communication Commands"

BM-5A mode communication commands

 "4.4 BM-5A Mode Communication Commands"

## 4.2 BM-5AC Mode Communication Commands

The following list summarizes the communication commands for the BM-5AC mode.

General commands

Communication Command	Function
RM	Sets the instrument to the remote mode.
LM	Sets the instrument to the local mode. (Cancels the remote mode.)
CA	Performs calibration. (Corrects the sensitivity of the photo detector.)
M0	Sets the instrument display to the luminance chromaticity xyL mode.
M1	Sets the instrument display to the luminance chromaticity u'v'L mode.
M2	Sets the instrument display to the correlated color temperature Tc · luminanceL mode.
WHO	Reads the product name. (BM-5AC is output.)
VER	Reads the software version.
SRL	Reads the manufacturing serial number.
SCC_# : space	Sets ON/OFF of color adjustment. #: 0 OFF 1 ON
LCC	Reads out ON/OFF of color adjustment. 0: OFF 1: ON

## General measurement commands

Communication Command	Function
ST	Performs measurement on the instrument. After measurement ends, returns measurement data from the instrument.
RA0	Sets the measurement range to the AUTO range (tristimulus value X2/Y/Z same range). Detects the measurement range having the largest electrical output of the tristimulus values, and sets all tristimulus values to the same measurement range.
RA1	Sets the measurement range to the AUTO range (tristimulus value X2/Y/Z optimum range). Detects and sets the optimum range for each of the tristimulus values.
RM0	Sets the measurement range to the manual range. Sets all tristimulus values X2/Y/Z to the same range. Specify the measurement using the Rn command.
RM1	Sets the measurement range to the manual range. Sets each of the tristimulus values X2/Y/Z to individual measurement ranges. Specify the measurement using the Xn, Yn and Zn commands.
Rn	Sets the measurement range. n: 1 to 5 Sets all tristimulus values X2/Y/Z to the same range. This command is used for specifying the measurement range in the RM0 command.
Xn	Sets the measurement range of tristimulus value X2. n: 1 to 5 This command is used for specifying the measurement range in the RM1 command.
Yn	Sets the measurement range of tristimulus value Y. n: 1 to 5 This command is used for specifying the measurement range in the RM1 command.
Zn	Sets the measurement range of tristimulus value Z. n: 1 to 5 This command is used for specifying the measurement range in the RM1 command.
TF	Performs measurement taking one measurement as one data.
TS	Performs measurement taking the average value as 1 data. Set the number of averages in the function mode. Setting method  "3.2.3 Setting the Averaging Count"

## Commands for analog waveform observation

Communication Command	Function
AN	Sets the analog output response speed to normal. Set this command when performing general measurement of luminance chromaticity.
AF	Sets the analog output response speed to high speed. Set this command when observing analog waveforms.
FX	Sets the internal tristimulus value filter to X2.
FY	Sets the internal tristimulus value filter to Y.
FZ	Sets the internal tristimulus value filter to Z.

## Commands for setting the correction factor

Communication Command	Function
FR	Reads the number of the correction factor currently being used.
F <sub>n</sub>	Writes the number of the correction factor to be used. n: Number of the correction factor to be used (0 to 15)
R <sub>F</sub> <sub>n</sub>	Reads the correction factor. n: Number of the correction factor to be read (1 to 15)
W <sub>n</sub> _xxxx_yyyy_zzzz_cccc _: space	Writes the correction factor. n: Number of the correction factor to be written (1 to 15) xxxx: Correction factor X <sub>2</sub> yyyy: Correction factor Y zzzz: Correction factor Z cccc: Comment. Maximum 50 bytes. The character of SPACE is not allowed.
C <sub>F</sub> <sub>n</sub>	Clears the correction factor. n: Number of the correction factor to be cleared (1 to 15)
F <sub>K</sub> <sub>n</sub>	Switches between normal correction/direct correction. n: 1 or 2, 1: Normal correction, 2: Direct correction
F <sub>K</sub> <sub>R</sub>	Reads the current correction type. Return value 1: Normal correction 2: Direct correction (direct correction)
F <sub>A</sub> <sub>G</sub> <sub>n</sub>	Enables area correction. n: Number of the area correction group (1 to 10)
F <sub>O</sub> (O: alphabets)	Disables area correction.
C <sub>G</sub> <sub>L</sub> <sub>n</sub>	Clears the chromaticity area in the area correction factor per each individual group. n: Number of the area correction group (1 to 10)
F <sub>G</sub> <sub>R</sub>	Reads the number of the area correction group currently being used.
R <sub>G</sub> <sub>m</sub> <sub>K</sub> <sub>n</sub>	Reads the area correction factor. m: Group Number (1 to 10) n: Area Number (1 to 5)
R <sub>G</sub> <sub>m</sub> <sub>L</sub> <sub>n</sub>	Reads the chromaticity area in the area correction factor. m: Group Number (1 to 10) n: Area Number (1 to 5)
W <sub>G</sub> <sub>m</sub> <sub>K</sub> <sub>n</sub> _####_####_#### _: space	Writes the area correction factor. m: Group Number (1 to 10) n: Area Number (1 to 5)
W <sub>G</sub> <sub>m</sub> <sub>L</sub> <sub>n</sub> _####_####_#### _: space	Writes the chromaticity area in the area correction factor. m: Group Number (1 to 10) n: Area Number (1 to 5)

"\_" indicates a space. "####" indicates a number.

When a communication command is sent from the PC, the instrument returns "OK" as the reception acknowledgement command. When the instrument receives an illegal command, it returns "NO".

## 4.2.1 ST Command

When this command is sent to the instrument, measurement starts. After measurement ends, the measurement data is sent from the instrument.

### Transmission from PC to BM-5AC

After the USB or RS-232C line has been made active, the PC transmits the character string "ST" (ASCII code 53H 54H), followed by Cr (0Dh), Lf (0Ah).

### Acknowledgement of reception from BM-5AC

After the BM-5AC receives "ST" + (Cr·Lf), it returns "OK" + (Cr·Lf) as the acknowledgement command, and starts measurement.

### Communication of measurement data

After measurement ends, the instrument transmits the measurement conditions and measurement data. 1 data string is appended with the delimiter (Cr·Lf), and the data is sent. After all data is transmitted, the end code "END" is transmitted.

Output format of measurement data → "4.3 Remote Measurement Output Format"

The data check is not performed.

Data continues to be sent from the BM-5AC until "END" is sent.

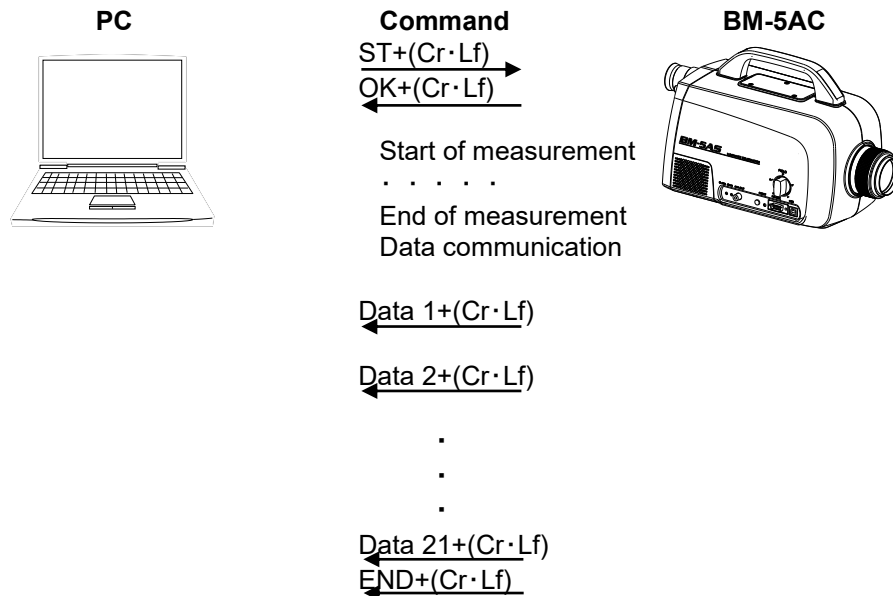

When error code E003 or E004 is displayed → "4.5 Error Codes"

## 4.2.2 CA Command

Performs calibration.

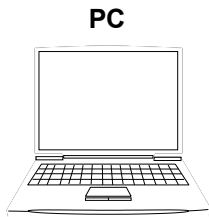

Command  
CA+(Cr·Lf)  
OK+(Cr·Lf) →

Execution of calibration

← END+(Cr·Lf)

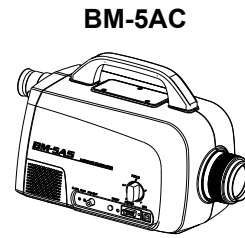

## 4.2.3 TF Command

Switches the instrument measurement mode to the SINGLE mode (1 measurement).

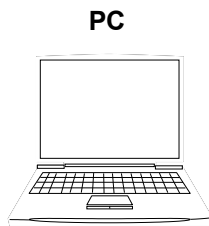

Command  
TF+(Cr·Lf)  
OK+(Cr·Lf) →

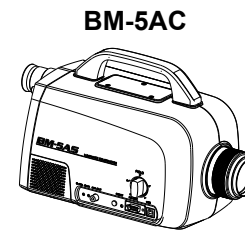

## 4.2.4 TS Command

Switches the instrument measurement mode to the AVERAGE mode (average measurement).

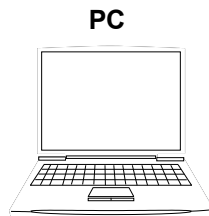

Command  
TS+(Cr·Lf)  
OK+(Cr·Lf) →

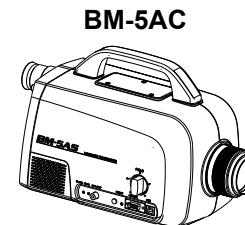

## 4.2.5 RA0/RA1 Commands

Switches the measurement range of the instrument to the AUTO range.

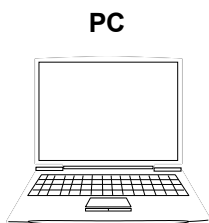

Command  
RA0 (or RA1) +(Cr·Lf)  
OK+(Cr·Lf) →

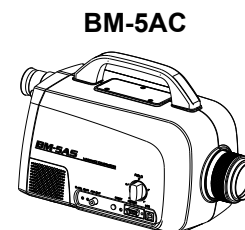

## 4.2.6 RM0/RM1 Commands

Switches the measurement range of the instrument to the MANUAL mode.

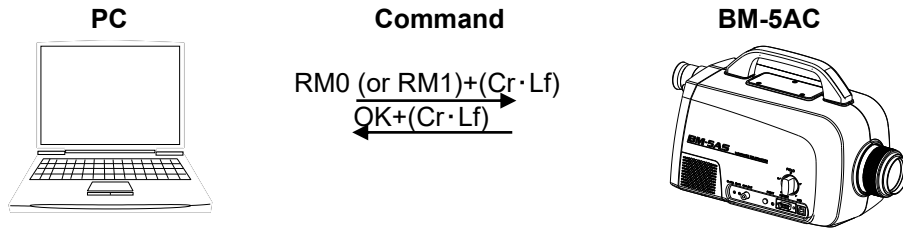

## 4.2.7 R Commands

The measurement range of the tristimulus values  $X_2/Y/Z$  in manual mode RM0 is set in [n].

R[n]

n: Measurement range 1 to 5

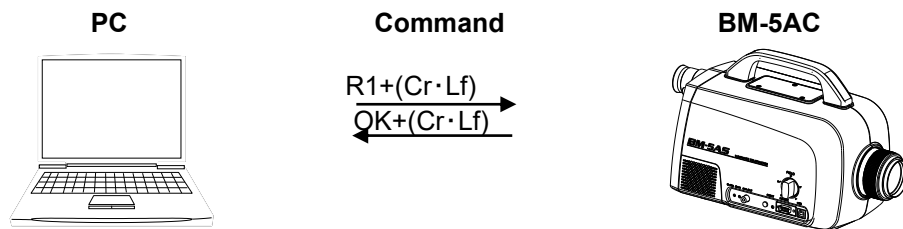

## 4.2.8 X / Y / Z Commands

The measurement range of the tristimulus values  $X_2/Y/Z$  in manual mode RM1 is set in [i], [j], and [k] respectively.

X[ i ]

i : Measurement range  $X_2$  1 to 5

Y[ j ]

j : Measurement range Y 1 to 5

Z[ k ]

k: Measurement range Z 1 to 5

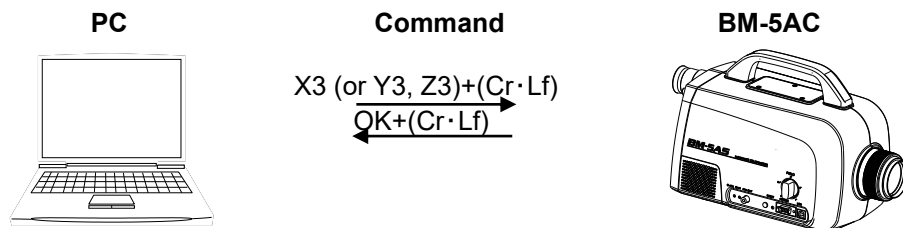

## 4.2.9 AN/AF Commands

Switches the analog output response speed of the light detecting analog circuit.

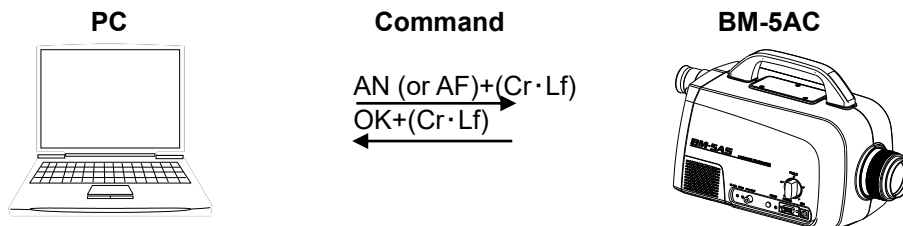

## 4.2.10 FX/FY/FZ Commands

Fixes the built-in tristimulus value filter at any position.

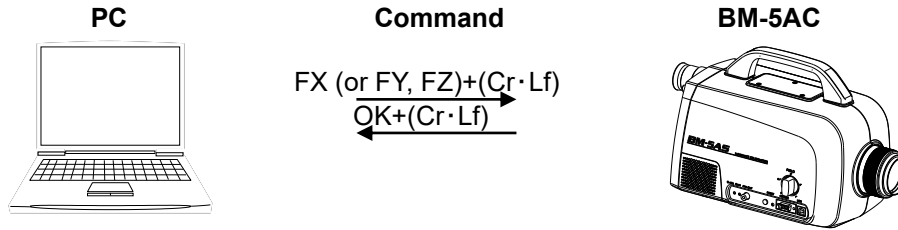

## 4.2.11 FR Command

Reads the correction factor currently being used by the instrument.

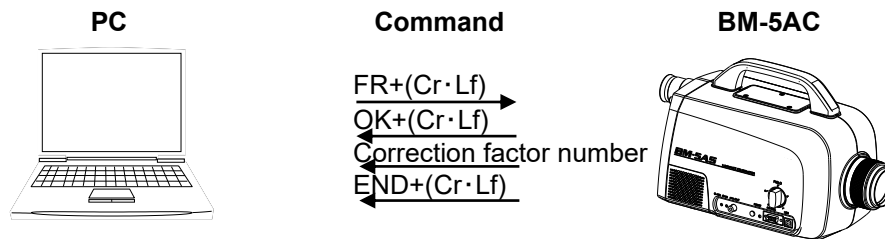

## 4.2.12 F Commands

Writes the number of the correction factor to be applied to the instrument.

F [n] : n: Number of the correction factor to be used. 0 to 15

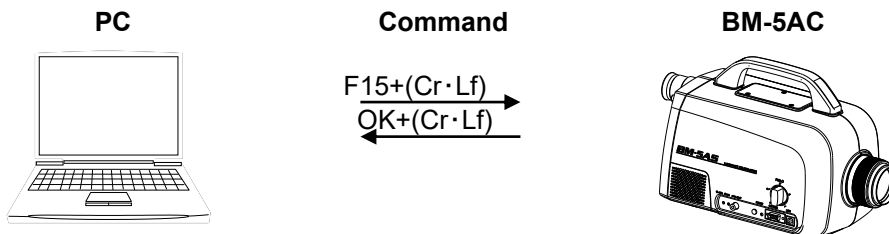

## 4.2.13 RF Command

Reads the correction factor in the instrument.

R [n] : n: Number of the correction factor to be read. 1 to 15

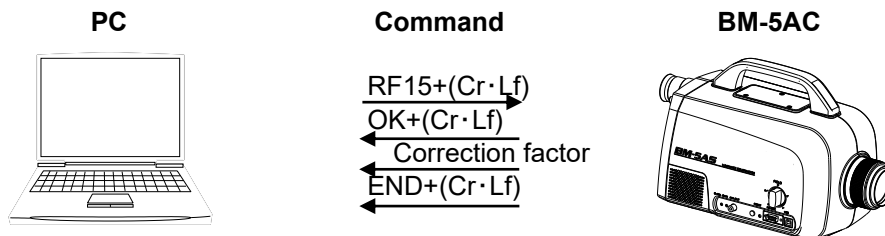

## 4.2.14 WF Command

Writes the correction factor to the instrument.

WF [n]\_xxxx\_yyyy\_zzzz\_cccc    n : Number of the correction factor to be written. 1 to 15  
 xxxx : Correction factor X2  
 yyyy : Correction factor Y  
 zzzz : Correction factor Z  
 cccc : Comments. Maximum 50 bytes.  
 The character of SPACE is not allowed.

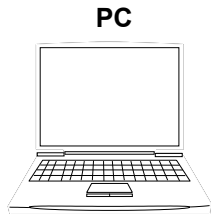

**Command**

WF10\_1.000\_1.000  
 \_1.000\_SAMPLEFACTOR  
 → +(Cr·Lf)  
 ← OK+(Cr·Lf)

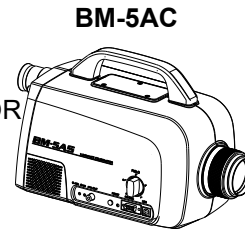

## 4.2.15 CF Command

Clears the correction factor in the instrument.

CF [n]    n : Number of the correction factor to be cleared. 1 to 15

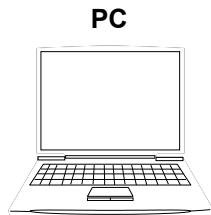

**Command**

CF10+(Cr·Lf)  
 →  
 ← OK+(Cr·Lf)

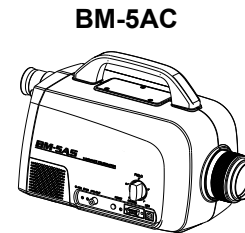

## 4.2.16 FK Command

Switches between normal correction/direct correction when correction is applied on the instrument.

FK[n]    n : 1 Normal correction    2 Direct correction

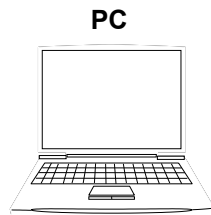

**Command**

FK1+(Cr·Lf)  
 →  
 ← OK+(Cr·Lf)

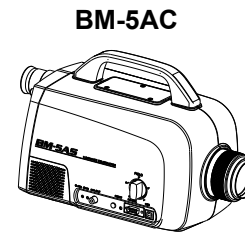

## 4.2.17 FKR Command

Reads the current correction type.

1: Normal correction 2: Direct correction

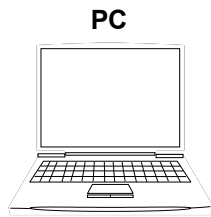

**Command**

FKR+(Cr·Lf)  
 OK+(Cr·Lf)  
 ← Correction type  
 END+(Cr·Lf)

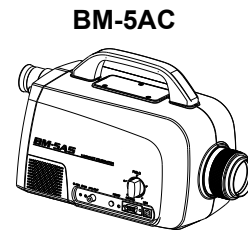

## 4.2.18 FAG Command

Enables area correction of the instrument.

FAG [n] : Number of the area correction factor group to be enabled. 1 to 10

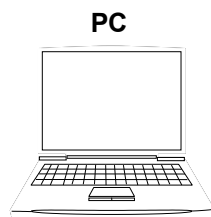

**Command**

FAG2+(Cr·Lf)  
 OK+(Cr·Lf)  
 ←

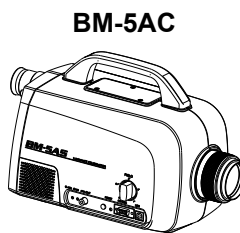

## 4.2.19 FO Command (O: alphabet)

Disables area correction of the instrument.

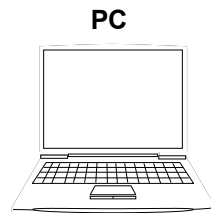

**Command**

FO+(Cr·Lf)  
 OK+(Cr·Lf)  
 ←

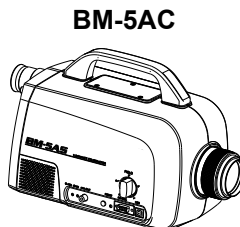

## 4.2.20 CGL Command

Clears the chromaticity area in the area correction factor per each individual group.

CGL [n] : Number of area correction factor group whose chromaticity area is to be cleared. 1 to 10

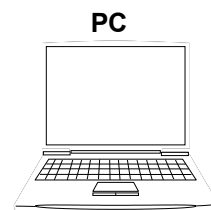

**Command**

CGL1+(Cr·Lf)  
 OK+(Cr·Lf)  
 ←

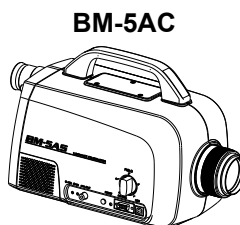

## 4.2.21 FGR Command

Reads the area correction factor group Number currently being used by the instrument.

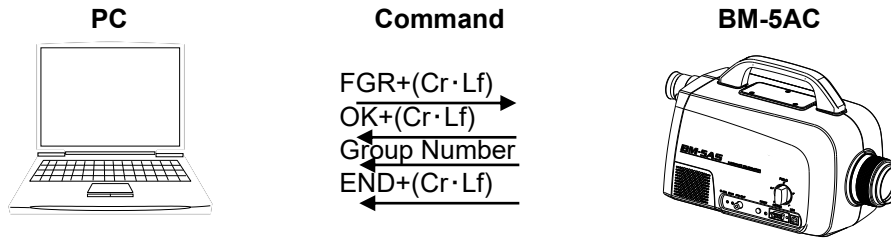

## 4.2.22 RGmKn Command

Reads the area correction factor in the instrument.

RG[m]K[n] : m: Number of the area correction factor group. 1 to 10  
n: area Number 1 to 5

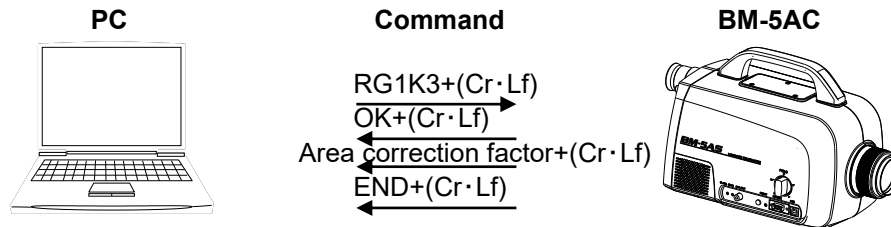

## 4.2.23 RGmLn Command

Reads the chromaticity area of the correction factor area in the instrument.

RG[m]L[n] : m: Number of the area correction factor group. 1 to 10  
n: area Number 1 to 5

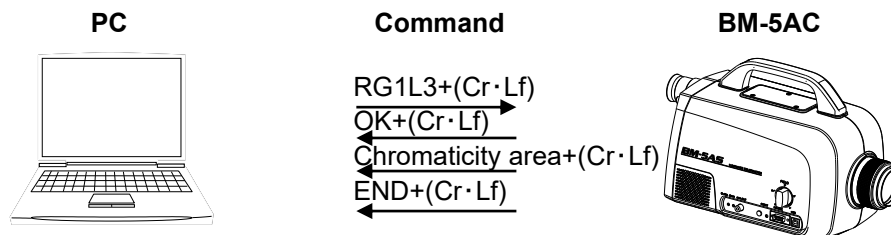

### 4.2.24 WGmKn Command

Writes the area correction factor to the instrument.

WG[m]K[n] : m: Number of the area correction factor group. 1 to 10  
n: area Number 1 to 5

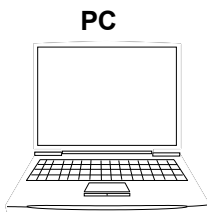

Command

WG1K3\_####\_####\_####+(Cr·Lf)  
 OK+(Cr·Lf)  
 ####\_####\_####+(Cr·Lf)  
 END+(Cr·Lf)

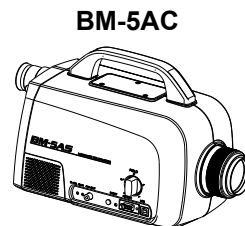

The values for correction factors KX, KY and KZ are entered in order to ####\_####\_####.

### 4.2.25 WGmLn Command

Writes the chromaticity area in the area correction factor to the instrument.

WG[m]L[n] : m: Number of the area correction factor group. 1 to 10  
n: area Number 1 to 5

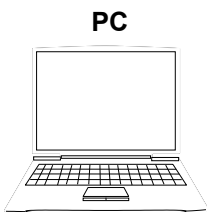

Command

WG1L3\_####\_####\_####\_####\_####+(Cr·Lf)  
 OK+(Cr·Lf)  
 ####\_####\_####\_####\_####+(Cr·Lf)  
 END+(Cr·Lf)

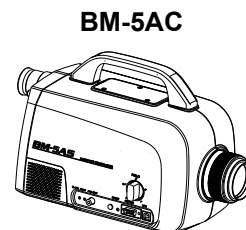

The minimum value of chromaticity x, minimum value of chromaticity y, maximum value of chromaticity x, maximum value of chromaticity y, and luminance are entered in order to ####\_####\_####\_####\_####.

### 4.2.26 WHO/VER/SRL Command

Reads the model name, manufacturing serial number, and program version of the instrument.

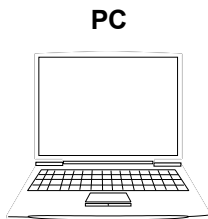

command

WHO/VER/SRL+(Cr·Lf)  
 OK+(Cr·Lf)  
 Model name/manufacturing serial  
 number/version  
 +(Cr·Lf)  
 END+(Cr·Lf)

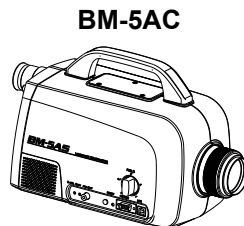

### 4.2.27 SCC Command

Sets ON/OFF of color adjustment.

0: OFF 1: ON

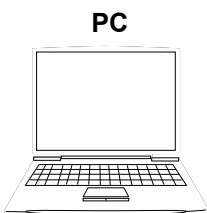

Command

SCC\_#+(Cr·Lf)  
 OK+(Cr·Lf)

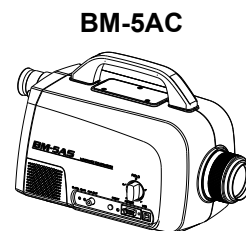

## 4.2.28 LCC Command

---

Reads out ON/OFF of color adjustment.  
0: OFF 1: ON

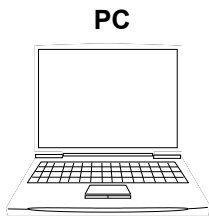

**Command**

LCC+(Cr·Lf)  
OK+(Cr·Lf)  
Color Adjustment+(Cr·Lf)  
END+(Cr·Lf)

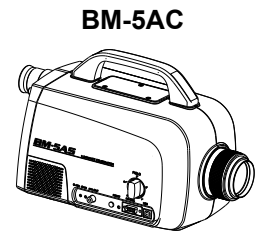

## 4.3 Remote Measurement Output Format

The output format of the data from the instrument during remote measurement (ST command) is as follows.

### ■BM-5AC mode

Row Number	Output Data Example	Data Content																													
1	D*	Indicates the brightness of the measurement target with respect to the measurement range of the instrument. D0: Normal D1: Under D2: Over Under range-D1, all of tristimulus values X <sub>2</sub> Y Z are displayed in set range below the value of the following table.																													
		<table border="1"> <thead> <tr> <th>Measuring Field</th> <th colspan="3">Tristimulus value (range 1)</th> <th rowspan="5">The values in ranges 2 to 5 are values obtained by multiplying 10X, 100X, 1000X, and 1000X, respectively.</th> </tr> <tr> <th></th> <th>X<sub>2</sub></th> <th>Y</th> <th>Z</th> </tr> </thead> <tbody> <tr> <td>3 °</td> <td>0.008</td> <td>0.009</td> <td>0.009</td> </tr> <tr> <td>2 °</td> <td>0.018</td> <td>0.020</td> <td>0.020</td> </tr> <tr> <td>1 °</td> <td>0.072</td> <td>0.080</td> <td>0.080</td> </tr> <tr> <td>0.2 °</td> <td>1.8</td> <td>2.0</td> <td>2.0</td> </tr> <tr> <td>0.1 °</td> <td>7.2</td> <td>8.0</td> <td>8.0</td> </tr> </tbody> </table>	Measuring Field	Tristimulus value (range 1)			The values in ranges 2 to 5 are values obtained by multiplying 10X, 100X, 1000X, and 1000X, respectively.		X <sub>2</sub>	Y	Z	3 °	0.008	0.009	0.009	2 °	0.018	0.020	0.020	1 °	0.072	0.080	0.080	0.2 °	1.8	2.0	2.0	0.1 °	7.2	8.0	8.0
		Measuring Field	Tristimulus value (range 1)			The values in ranges 2 to 5 are values obtained by multiplying 10X, 100X, 1000X, and 1000X, respectively.																									
			X <sub>2</sub>	Y	Z																										
		3 °	0.008	0.009	0.009																										
2 °	0.018	0.020	0.020																												
1 °	0.072	0.080	0.080																												
0.2 °	1.8	2.0	2.0																												
0.1 °	7.2	8.0	8.0																												
2	M*	Measurement mode M0: xyL mode M1: u'v'L mode M2: Tc/duv/L mode																													
3	T*	Measurement averaging TF: Single measurement TS: Averaging measurement																													
4	R*	Measurement range setting RA0: AUTO range (common range) RA1: AUTO range (individual range) RM0: Manual range (common range) RM1: Manual range (individual range)																													
5	X*	X2 Range (range X1 to X5)																													
6	Y*	Y range (range Y1 to Y5)																													
7	Z*	Z range (range Z1 to Z5)																													
8	UC	Unit UC: cd/m <sup>2</sup>																													
9	F*	Measuring Field F1: 0.1° F2: 0.2° F3: 1° F4: 2° F5: 3°																													
10	K*	Correction factor K0: No correction K1 to K9: Correction factor number.																													
11	FG*	Area correction group number. FG0: No correction FG1 to FG10: Area correction group number																													
12	GK*	Applicable chromaticity area GK0: No applicable chromaticity area GK1 to GK5: Color data number corresponding to chromaticity area																													
13	1.234E+56	Luminance																													
14	1.234E+56	Tristimulus value X																													
15	1.234E+56	Tristimulus value Y																													
16	1.234E+56	Tristimulus value Z																													
17	1.234	Chromaticity x																													
18	1.234	Chromaticity y																													
19	1.234	Chromaticity u'																													
20	1.234	Chromaticity v'																													
21	12345	Color temperature																													
22	123456	Deviation																													
23	END	Data end command																													

## 4.4 BM-5A Mode Communication Commands

The following list summarizes the communication commands for the BM-5A mode.

Communication Command	Function
ST	Sets the instrument to the measurement status. After measurement ends, returns measurement data from the instrument.
CA	Performs calibration.
TF	Performs measurement taking one measurement as one data.
TS	Performs measurement taking the average value of five measurements as one data.
RA	Sets the measurement range to the AUTO range.
RM	Sets the measurement range to the manual range.
Rn	Sets the measurement range to range n. n: 1 to 5
M0	Switches the display mode. : xyL mode
M1	Switches the display mode. : u' v' L mode
M2	Switches the display mode. : T <sub>c</sub> , duv, L mode

## ■BM-5A mode communication format

Output data are measurement conditions and various measurement color values. There are three output formats as follows depending on the measurement mode.

- **M0 command-**

DnT\*R\*RnU\*Fn\_

X= \_#.##### \_y= \_#.##### \_ X= \_#.###E±## \_ Y= \_#.###E±## \_ Z= \_#.###E±##CR

- **M1 command-**

DnT\*R\*RnU\*Fn\_

u'= \_#.##### \_ v'= \_#.##### \_ X= \_#.###E±## \_ Y= \_#.###E±## \_ Z= \_#.###E±##CR

- **M2 command-**

DnT\*R\*RnU\*Fn\_

Tc= \_##### \_ duv= \_#.##### \_ X= \_#.###E±## \_ Y= \_#.###E±## \_ Z= \_#.###E±##CR

○Explanation of measurement conditions

- Dn: Judgment of measurement status

n=0 ... Normal

1 ... Over range: This is displayed when at least 1 of tristimulus values X<sub>2</sub>Y Z exceeds the setting range.

2 ... Under range: This is displayed when all of tristimulus values X<sub>2</sub>Y Z are at the values in the table below or lower.

Values for which is "D2" displayed

Measuring Field	Tristimulus value (range 1)		
	X <sub>2</sub>	Y	Z
3 °	0.008	0.009	0.009
2 °	0.018	0.020	0.020
1 °	0.072	0.080	0.080
0.2 °	1.8	2.0	2.0
0.1 °	7.2	8.0	8.0

※The values in ranges 2 to 5 are values obtained by multiplying 10X, 100X, 1000X, and 1000X, respectively.

The value of the above table is a design value.

It is likely to differ somewhat in each product.

- T\* : Measurement count      TF : 1 measurement,      TS : Average of 5 measurements
- R\* : Measurement range      RA : AUTO,      RM : MANUAL
- Rn : Measurement range used for measurement      n : 1 to 5
- U\* : unit      UC : cd/m<sup>2</sup>
- Fn : Measuring field      F1 : 0.1°, F2: 0.2°, F3: 1°, F4: 2°, F5: 3°

\* \_ indicates a space.

\* # indicates a numerical value.

\* The carriage return code (0x0d) is indicated by CR.

\* When the CR(0x0d) carriage return code is not read by the computer, this instrument judges that transmission is incomplete, and the instrument enters a non-operable state.

## 4.5 Error Codes

When an error occurs on the instrument when it is connected to a PC and performing measurement, the following error messages are sent and displayed on the PC.

Error Code	Description
E003	The measuring field is in error. Make sure the measuring field is set properly.
E005	Calibration error.
E006	The value of the correction factor to be written is in error.
E008	Area correction limit write error. The value of one side of the specified square area is greater than 0.03.
E009	Area correction limit write error. A specified area range is overlapping another area in the same group.
E010	Area correction limit write error. The specified area is not overlapping the chromaticity diagram, or an illegal size has been specified as the area.
E011	Area correction limit write error. The read value does not match the written value. *On this instrument, make sure that read values are matching after writing ends.
E012	Communication error. The power OFF then back ON again.

# 5. USB Driver

The procedure for installing the USB Driver in the PC is as follows.

- 1 Place the CS-900A CD-ROM in the CD-ROM drive.
- 2 Select and double-click the “dpinst.exe” file in [¥USB\_Driver¥{os name}¥ {x86} or {x64}] folder in the CD-ROM via Explorer.

OS	Windows® 10 Pro (32bit/64bit) Windows® 11 Pro (64bit)
----	--

For example, in the case of Windows10(64bit), it becomes {USB\_DRIVER¥Windows10¥x64}.

- 3 The User Account Control Dialog appears. Click [OK] button.
- 4 The Device Driver Installation Wizard appears. Click [Next] button.

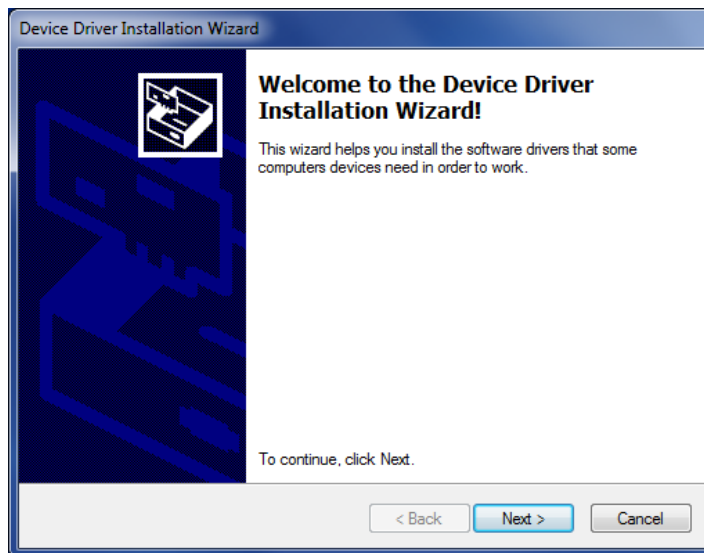

- 5 The following dialog will be displayed, start installing the USB Driver.

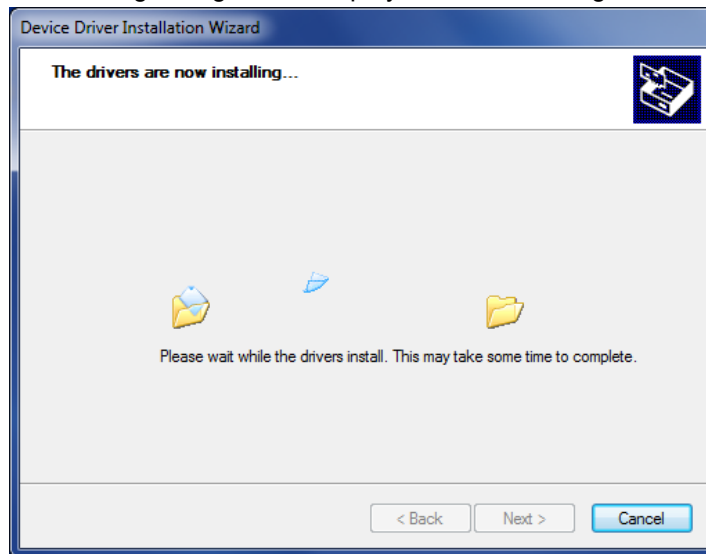

- 6 After installation of USB Driver, The following dialog will be displayed. Click the [Finish] button.

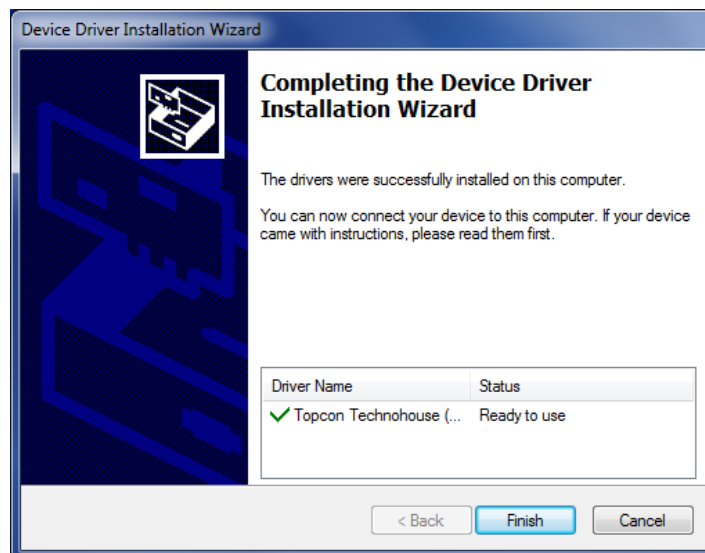

# Appendix

## Specifications

### Measuring Field

3° / 2° / 1° / 0.2° / 0.1° Switch type

### Optical system

Viewfinder field of view : 5°

Objective lens : f = 80 mm F2.5

### Spectral Sensitivity Characteristics

Similar to color matching function CIE 1931

\* Satisfies router conditions JIS Z 8724-1997.

### Photo detector

Photomultiplier

### Measurement Diameter

(unit: mm dia.)

Measuring Field	Measurement distance (m)				
	0.35	0.5	1	5	10
3°	15.0	23.1	49.2	255	510
2°	10.0	15.4	32.8	169	341
1°	5.0	7.7	16.4	85	170
0.2°	1.0	1.5	3.3	17	34
0.1°	0.5	0.8	1.6	8	17

\* May change slightly according to the machining precision of the aperture mirror.

\* The measurement distance is the distance from the tip of the metal fixture on the instrument of the objective lens.

### Measurement Functions

The following measurements can be performed by switching the display mode.

x, y, L (x y : chromaticity, L: luminance) and  $\pm\Delta$

u', v', L (u' v' : chromaticity, L: luminance) and  $\pm\Delta$

X Y Z(X, Y, Z: tristimulus values) and  $\pm\Delta$

Tc, duv, L (Tc: Color temperature, duv: Deviation) and  $\pm\Delta$

CIE 1976 L\*a\*b\*  $\Delta E_{ab}^*$  and  $\pm\Delta$

CIE 1976 L\*u\*v\*  $\Delta E_{uv}^*$  and  $\pm\Delta$

\* $\pm\Delta$  indicates the difference from the reference value.

For example, in the case of x, y, L, this means  $\Delta x$ ,  $\Delta y$  and  $\Delta L$ .

### Measurement Time

Approx. 2 seconds (This is the measurement interval in the SINGLE measurement mode.)

### Analog Output Response Speed

(unit: ms approx.)

	Range1	Range2	Range3	Range4	Range5
<b>NORMAL</b>	30				
<b>FAST</b>	5	0.5	0.05	0.5	0.05

The response speed in the table above is the time that it takes analog output from the instrument to reach 90% of the peak value, when measuring an LED driven by a square wave from a function generator.

### Luminance Unit

Candela per square meter (cd/m<sup>2</sup>)

### Luminance Display Ranges

(unit: cd/ m<sup>2</sup>)

Measuring Field	Range 1	Range 2	Range 3	Range 4	Range 5
<b>3°</b>	0.00005 to 0.15	0.0005 to 1.5	0.005 to 15	0.05 to 150	0.5 to 1 500
<b>2°</b>	0.0001 to 0.3	0.001 to 3	0.01 to 30	0.1 to 300	1 to 3 000
<b>1°</b>	0.0004 to 1.2	0.004 to 12	0.04 to 120	0.4 to 1200	4 to 12 000
<b>0.2°</b>	0.01 to 30	0.1 to 300	1 to 3 000	10 to 30 000	100 to 300 000
<b>0.1°</b>	0.04 to 120	0.4 to 1 200	4 to 12 000	40 to 120 000	400 to 1 200 000

The measurement ranges are indicated as approximate values since they depend on the machining precision of the aperture mirror.

Even when luminances in the above ranges are being measured, measurement is sometimes not possible depending on the measurement mode used. The cause of this trouble is that output of X<sub>2</sub> and Z are over range, and it does not mean that the instrument is broken. Be careful when measuring extreme red or blue colored light.

### Luminance Accuracy

Within ±4% (AUTO range, A light source)

Guaranteed Accuracy Range

Measuring Field	Guaranteed Accuracy Range
3°	0.005 cd/m <sup>2</sup> or more
2°	0.01 cd/m <sup>2</sup> or more
1°	0.04 cd/m <sup>2</sup> or more
0.2°	1 cd/m <sup>2</sup> or more
0.1°	4 cd/m <sup>2</sup> or more

## Chromaticity Accuracy

### Chromaticity 1

$\Delta x, \Delta y$  : Within  $\pm 0.005$  (AUTO range, A light source)

Guaranteed Accuracy Range

Measuring Field	Guaranteed Accuracy Range
3°	0.005 cd/m <sup>2</sup> or more
2°	0.01 cd/m <sup>2</sup> or more
1°	0.04 cd/m <sup>2</sup> or more
0.2°	1 cd/m <sup>2</sup> or more
0.1°	4 cd/m <sup>2</sup> or more

### Chromaticity 2

$\Delta x, \Delta y$  : Within  $\pm 0.008$  (Color adjustment : ON)

For a combination of the standard source A and the next colored glass

O-55, Y-48, A-73B, IRA-05, T-44, R-61, B-46, V-44, G-54: Manufactured by Asahi Techno Glass Corp.

## Repeatability

### Luminance

For a measuring field of 3 degrees (The table below shows each of the measuring fields, specification and luminance ranges.)

0.005 to 0.025 cd/m<sup>2</sup> : 2% or less

0.025 cd/m<sup>2</sup> or more : 0.8% or less

(2 $\sigma$ , SINGLE mode, AUTO range, standard source A)

Measuring Fields and Standard Values

Measuring Field	Luminance Range and Specification
3°	Less than 0.005 to 0.025cd/m <sup>2</sup> : 2% or less 0.025cd/m <sup>2</sup> or more : 0.8% or less
2°	Less than 0.01 to 0.05 cd/m <sup>2</sup> : 2% or less 0.05 cd/m <sup>2</sup> or more : 0.8% or less
1°	Less than 0.04 to 0.2 cd/m <sup>2</sup> : 2% or less 0.2 cd/m <sup>2</sup> or more : 0.8% or less
0.2°	Less than 1 to 5 cd/m <sup>2</sup> : 2% or less 5 cd/m <sup>2</sup> or more : 0.8% or less
0.1°	Less than 4 to 20 cd/m <sup>2</sup> : 2% or less 20 cd/m <sup>2</sup> or more : 0.8% or less

### Chromaticity

xy within 0.003 (2 $\sigma$ , SINGLE mode, AUTO range, standard source A)

Guaranteed Accuracy Range

Measuring Field	Guaranteed Accuracy Range
3°	0.025 cd/m <sup>2</sup> or more
2°	0.05 cd/m <sup>2</sup> or more
1°	0.2 cd/m <sup>2</sup> or more
0.2°	5 cd/m <sup>2</sup> or more
0.1°	20 cd/m <sup>2</sup> or more

## Temperature Characteristics

Within  $\pm 3\%$  (23°C is regarded as standard in the range 0°C to 40°C.)

**Humidity Characteristics**

Within ±3% (60% RH is regarded as standard at 85% RH or less.)

**Calibration Reference**

TechnoOptis calibration reference (Standard source A, 23°C ±3°C)

**Display**

Dot-matrix LCD 20 characters x 4 rows with a backlight

**Interface**

USB/RS-232C

**Analog Output**

Analog voltage output proportional to X<sub>2</sub>, Y, Z

**Power Supply**

AC adapter (standard supplied part)

**Power Consumption**

Approximately 20 VA when using an AC adapter

**Operating Conditions**

Temperature : 0°C to 40°C

Humidity : 85% RH or less (no condensation)

**Storage Conditions**

Temperature : -20°C to 60°C

Humidity : 85% RH or less (no condensation)

**External Dimensions**

Approximately 355 mm (Length) x 154 mm (Width) x 212 mm (Height)

**Weight**

Approximately 3.6 kg

\* The precision value (luminance and chromaticity) is the specification value by our standard light source and measurement condition.

Measurement error that is out of specification value may occur by the difference of the light source, measurement condition and measurement environment.

<p>Republic of Korea</p>	<p>KC:Class A</p>	<p>해당 무선설비는 전파혼신 가능성이 있으므로 인명안전과 관련된 서비스는 할 수 없습니다</p> <p>A급 기기 (업무용 방송통신기자재)</p> <p>이 기기는 업무용(A급) 전자파적합기기로서 판매자 또는 사용자는 이 점을 주의하시기 바라며, 가정외의 지역에서 사용하는 것을 목적으로 합니다</p>
--------------------------	-------------------	---

**FCC Compliance Information**

This device complies with Part 15 of FCC Rules. Operation is subject to the following two conditions:

- (1) the device may not cause interference, and
- (2) the device must accept any interference, including interference that may cause undesired operation of this device.

This equipment has been tested and found to comply with the limits for a Class A digital device, pursuant to part 15 of the FCC Rules.

These limits are designed to provide reasonable protection against harmful interference when the equipment is operated in commercial environment. This equipment generates, uses, and can radiate radio frequency energy and if not installed and used in accordance with the instruction manual, may cause harmful interference to radio communications. Operation of this equipment in a residential area is likely to cause harmful interference in which case the user will be required to correct the interference at his own expense

# Appended Tables

---

## Color Correction Factor

Standard Light	
A	1.000
D65	1.020
Filter (under standard source A)	
R-61	0.977
O-55	0.975
Y-48	0.996
G-52	1.025
B-46	1.052
Fluorescent Lamp	
Three band fluorescent light	1.018
White light (FL-W)	1.003
Daylight (FL-D)	1.014
HID Lamp	
High-voltage mercury lamp (H-400)	0.999
Metal hydride lamp (M-400)	1.017
High-voltage sodium lamp (NH-400)	0.977
Color Television	
Red	1.012
Green	1.022
Blue	1.158
White	1.035

The above data was calculated from the spectral sensitivity of a sample on the instrument, and may vary slightly by instrument.

## Unit Conversion Table

cd/m <sup>2</sup> (nt)	cd/cm <sup>2</sup> (sb)	cd/ft <sup>2</sup>	rlx(asb)	Lamberts	Foot-Lamberts (ft-L)
1	0.0001	0.0929	3.1416	0.000314	0.2919
3.426	0.0003426	0.3183	10.764	0.001076	1

# System Diagrams

## Block Diagram

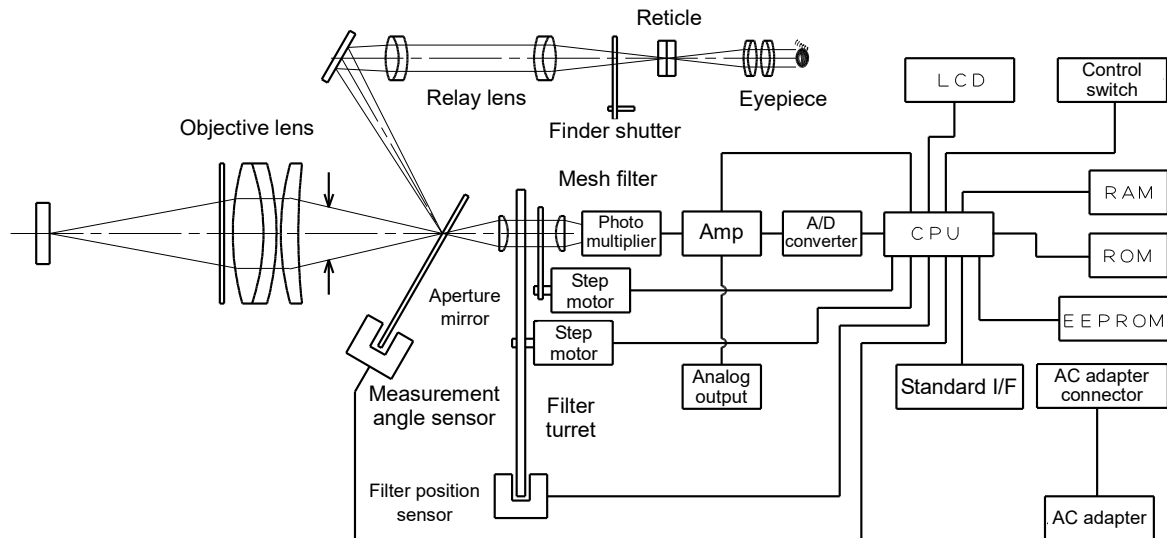

## Spectral Sensitivity Curves

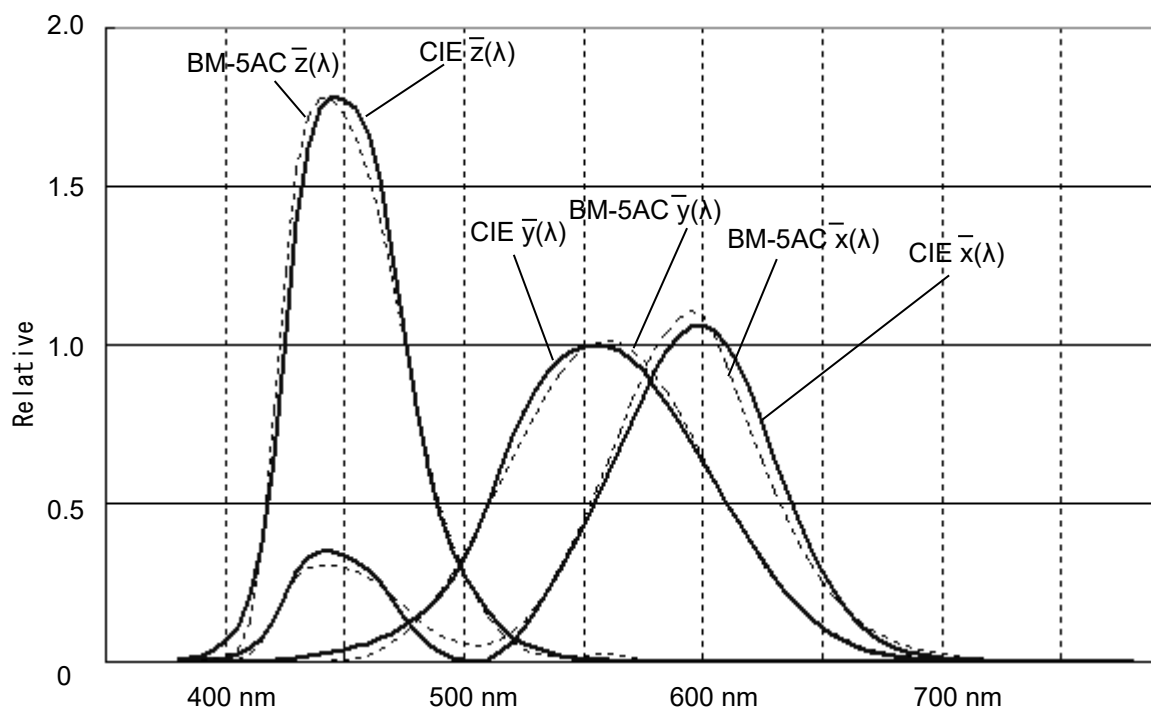

This data is one sample of the manufactured product. Data is different in each manufacturing product.

# External Dimensions



**Request**

Use only specified screws when using the tripod screw and screw holes for jig attachment. Do not tighten the screws any more than necessary. Doing so might cause internal breakage.

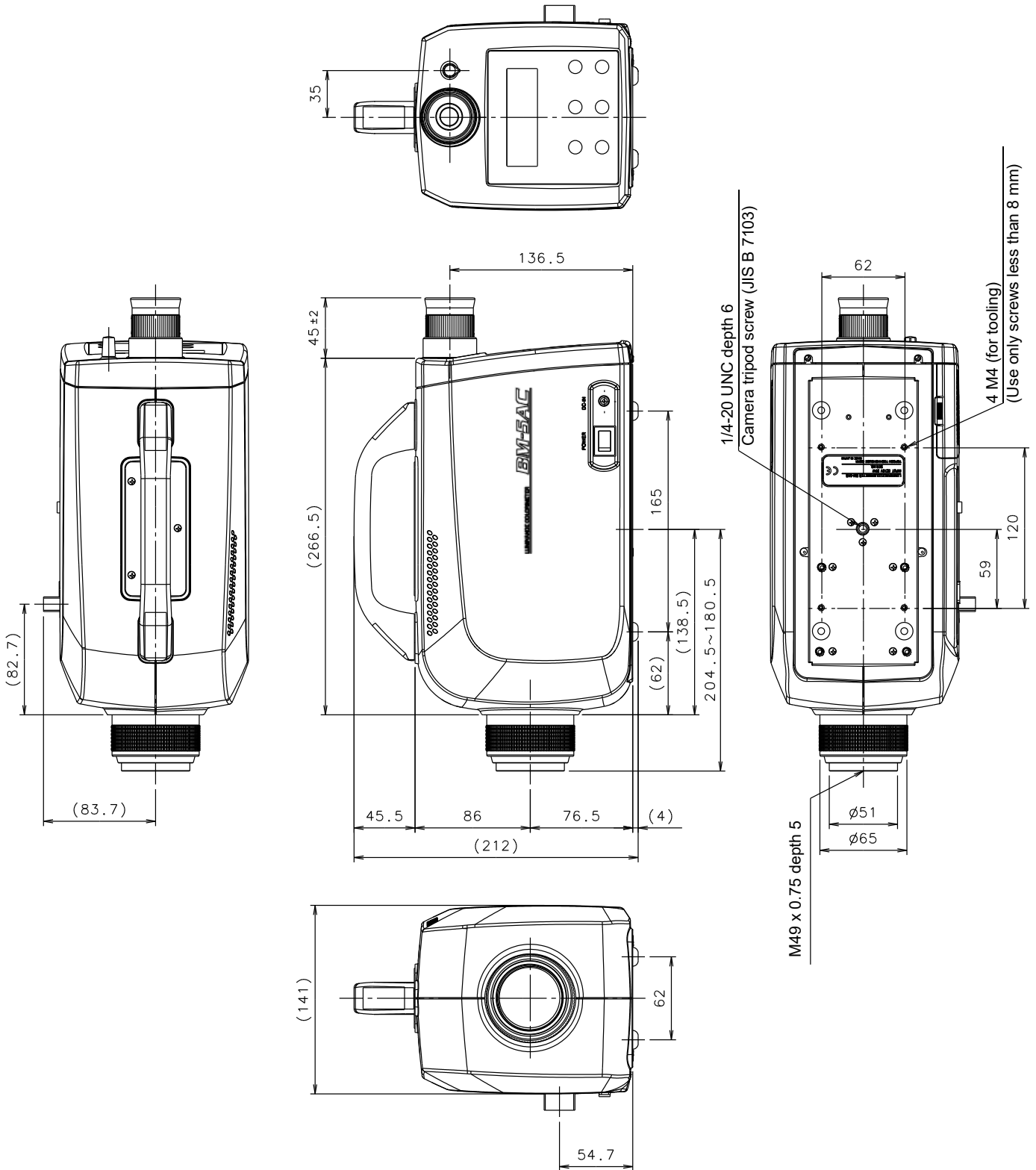

# Internal Calculation Processing

This instrument performs the following calculation processing on each piece of data.

## Chromaticity Coordinates

xy chromaticity coordinates of a XYZ color coordinate system

$$x = \frac{X}{X + Y + Z} \quad y = \frac{Y}{X + Y + Z}$$

u'v' chromaticity coordinates of a UCS color coordinate system

$$u' = \frac{4X}{X + 15Y + 3Z} \quad v' = \frac{9Y}{X + 15Y + 3Z}$$

## Lightness Index

$$L^* = 116 \left( \frac{Y}{Y_n} \right)^{\frac{1}{3}} - 16 \quad \frac{Y}{Y_n} > 0.008856$$

Y : Tristimulus value Y of an XYZ color coordinate system

Y<sub>n</sub> : Y value according to standard light on a perfect reflecting diffuser

However, when  $\frac{Y}{Y_n}$  is 0.008856 or less, the following formula must be applied.

$$L^* = 903.29 \left( \frac{Y}{Y_n} \right) \quad \frac{Y}{Y_n} \leq 0.008856$$

## Chromaticness Index

CIE 1976 L\*a\*b\* color coordinate system

$$a^* = 500 \left\{ \left( \frac{X}{X_n} \right)^{\frac{1}{3}} - \left( \frac{Y}{Y_n} \right)^{\frac{1}{3}} \right\} \quad \frac{X}{X_n} > 0.008856$$

$$b^* = 200 \left\{ \left( \frac{Y}{Y_n} \right)^{\frac{1}{3}} - \left( \frac{Z}{Z_n} \right)^{\frac{1}{3}} \right\} \quad \frac{Y}{Y_n} > 0.008856$$

$$\frac{Z}{Z_n} > 0.008856$$

X, Y, Z : Tristimulus values in the XYZ color coordinate system

X<sub>n</sub>, Y<sub>n</sub>, Z<sub>n</sub> : Tristimulus values in the XYZ color coordinate system on a perfect reflecting diffuser

However, if  $\frac{X}{X_n}$ ,  $\frac{Y}{Y_n}$  or  $\frac{Z}{Z_n}$  have a value less than 0.008856, substitute the corresponding cube roots in the above formula with the values as shown below.

$$7.787 \left( \frac{X}{X_n} \right) + \frac{16}{116}$$

$$7.787 \left( \frac{Y}{Y_n} \right) + \frac{16}{116}$$

$$7.787 \left( \frac{Z}{Z_n} \right) + \frac{16}{116}$$

**CIE 1976 L\*u\*v\* color coordinate system**

$$u^* = 13L^* (u' - u_n')$$

$$v^* = 13L^* (v' - v_n')$$

u', v' : CIE 1976 UCS color coordinate system

u\_n', v\_n' : u' and v' values according to standard light on a perfect reflecting diffuser

**Color Difference**

**CIE 1976 L\*a\*b\* color difference**  $\frac{1}{2}$

$$\Delta E^*_{ab} = \left\{ (\Delta L^*)^2 + (\Delta a^*)^2 + (\Delta b^*)^2 \right\}^{\frac{1}{2}}$$

$\Delta L^*$ ,  $\Delta a^*$ ,  $\Delta b^*$ : Difference in lightness indices  $L^*$ , and chromaticness indices  $a^*$  and  $b^*$  between two non-luminous object colors

**CIE 1976 L\*u\*v\* color difference**  $\frac{1}{2}$

$$\Delta E^*_{uv} = \left\{ (\Delta L^*)^2 + (\Delta u^*)^2 + (\Delta v^*)^2 \right\}^{\frac{1}{2}}$$

$\Delta L^*$ ,  $\Delta u^*$ ,  $\Delta v^*$ : Difference in lightness indices  $L^*$ , and chromaticness indices  $u^*$  and  $v^*$  between two non-luminous object colors

**Color Temperature, Deviation**

Color temperature and deviation are calculated according to JIS Z 8725 "Method for determining distribution temperature and color temperature or correlated color temperature of light source."

Color temperature display range  $1563K \leq T_c \leq 100000K$

Deviation display range  $-0.02 \leq d_{uv} \leq 0.02$

Deviation is the distance from the blackbody locus on the CIE 1960 UCS color diagram.

# Terminology

---

**Correction Factor:**

This refers to three factors, KX, KY and KZ, for correcting tristimulus values.

**Area Correction Factor:**

When an arbitrary area is specified on the xy and u'v' chromaticity diagrams, these factors are for correcting values that fall within that area.

**Correction Reference Sample:**

This is a sample for determining correction factors.

(e.g. a monitor TV whose tristimulus values have been valued as corrected through spectrometry)

**Standard sample:**

This is a sample used as the standard for color matching.

**White Board:**

This is a white board with good diffusion, made of barium sulfate, etc.

**Prompt:**

A message output by the instrument for instructing the operator to perform some operation.

**RAM (Random Access Memory):**

Memory that can be read and written. RAM can be thought of as volatile memory whose contents are lost when the instrument is turned OFF.

**EEPROM (Electric Erasable Programmable Read Only Memory):**

This is ROM whose contents can be erased electrically. EEPROM can be thought of as non-volatile memory that does not require a battery.

**Local Mode:**

This is the normal measurement status.

In this mode, the instrument is operated by the panel switches, and cannot be controlled by an external PC.

**Remote Mode:**

In this mode, the instrument is controlled by an external PC via the interface. It can also be controlled by its panel switches.

**Function Mode:**

This mode is for displaying and changing the data stored in the instrument's memory.

**Direct Connection Function:**

This function enables correction between 2 luminance colorimeters that are directly connected by an RS-232C cable.

## Warranty

### Warranty Period

1 year from the date of shipment

### Repairs during the Warranty Period

Failure occurring on the instrument when the instrument has been operated according to the instructions in the Instruction Manual and the failure caused by design or manufacture will be repaired free of charge.

### Repairs after the Warranty Period

Repairs after the warranty period are carried out if possible and must be paid in full by the user.

### Maintenance Period

The repair parts (\*1) are retained by us for eight years (\*2) after purchase.

The repairable period is this period that parts are kept in stock.

Even after the storage period has elapsed, there are cases in which repair may be possible, so contact your dealer or TechnoOptis.

(\*1) Maintenance and repair parts are parts that are required for maintaining the function of the product.

(\*2) We make utmost effort to keep maintenance and repair parts in stock for the complete storage period. However, due to unexpected occurrences, the storage period may be shortened.

### Disposal

Dispose of the instrument in accordance with local disposal and recycling laws and regulations.

### California, U.S.A only

This product contains a CR Lithium Battery which

Contains Perchlorate Material—special handling may apply

See [www.dtsc.ca.gov/hazardouswaste/perchlorate](http://www.dtsc.ca.gov/hazardouswaste/perchlorate)

※Products manufactured after April 2024 are not applicable.

---

### When you ask for service, advise us of the following data:

- |                               |   |
|-------------------------------|---|
| · Manufacturing serial number | Located on the ratings plate on the bottom of the device  |
| · Period of use               | The date of purchase of the instrument, and date of last calibration                                    |
| · Operating conditions        | Type of light source measured, instrument settings, measurement values, measurement state, etc.         |
| · Problem                     | Description of the trouble in as much detail as possible  |
| Contact information           | Make inquiries to the address indicated on the base of the rear inside cover of the Instruction Manual. |

Luminance  
Colorimeter

---

***BM-5AC***

---

Contact information:

**TechnoOptis Co., Ltd.**

4F, Imas Itabashi BASE, 2-4-1, Sakashita, Itabashi-ku, Tokyo 174-0043 JAPAN

◆ **For inquiries about the product:**

Tel +81-3(3558)2666      Fax +81-3(3558)4661

◆ **For inquiries about the after-care service including repairs:**

Tel +81-3(3558)2710      Fax +81-3(3558)3011

---

Luminance Colorimeter BM-5AC Instruction Manual

Publication date: September, 2016 First Edition

June, 2026 11th Edition

Published by: TechnoOptis Co., Ltd.

---