

# TechnoOptis

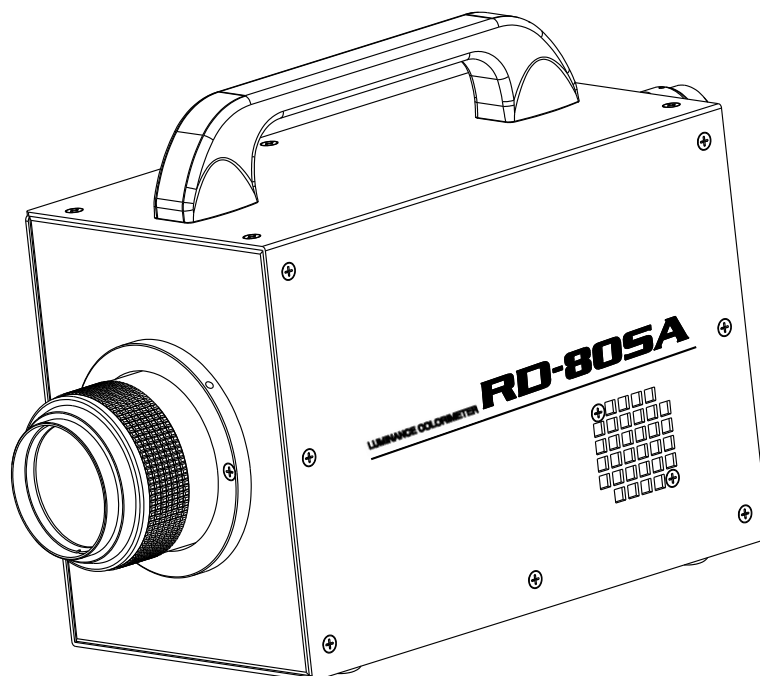

Instruction Manual  
**Luminance Colorimeter**

---

# ***RD-805A***

Rev.8



# Introduction

---

Thank you for purchasing our product, Luminance Colorimeter RD-80SA.

The RD-80SA is the instrument to detect building-up/Falling down time of the light from LCD, LCD backlight, and LED.



Read this manual carefully before using the RD-80SA in work applications.

## Precautions for use

- Be sure to only use the AC adapter supplied with this instrument, or a separately sold authorized AC adapter. Using a non-authorized AC adapter may result in a malfunction. The input voltage should be 100 VAC to 240 VAC, and the power supply frequency should be 50 Hz to 60 Hz.
- For energy saving, when the unit will not be used for an extended period of time, unplug the power plug from the socket.
- Keep the instrument away from water and liquid. This instrument is not water-resistant.
- Before using this instrument, be sure to warm it up for at least 30 minutes. If this instrument is not warmed up, output fluctuation may affect the measurement values, preventing highly accurate measurement results from being obtained.
- When using this instrument over a prolonged period of time, activate the Auto calibrate function. Output fluctuation of the photo detector may prevent highly accurate measurement results from being obtained.
- Do not use this instrument for measuring bright objects that exceed the measurement range, or for measuring extremely bright objects such as the sun. Doing so may damage the photo detector and prevent stable measurement.
- Do not use this instrument in dusty, very damp or humid areas, or in areas where corrosive gas may be generated.
- Do not use this instrument in areas where sudden changes in temperature might occur. This instrument contains a temperature compensation function. However, stable measurement may not be possible in environments where there are sudden changes in temperature.
- Do not subject this instrument to heavy impact such as dropping it. Also, avoid using or storing this instrument in areas subjected to constant vibration. This instrument uses high-precision optical parts and subjecting it to harsh conditions might cause a malfunction. Prevent this instrument from being subjected to direct vibration or impact by placing it in a carrying case (optional accessory) when carrying it.
- When storing this instrument, put it in a carrying case (Optional accessory), and store it at room temperature. Do not store the instrument in a hot or humid environment such as inside an automobile.
- To maintain measurement precision, perform calibration and maintenance on average once a year. When performing calibration, consult with your dealer or TechnoOptis.
- When requesting calibration, put this instrument in its carrying case (Optional accessory), and then put it in a cardboard box packed with shock-absorbing material before sending it.
- When calibration is performed, the measurement data stored in this instrument is deleted. Be sure to transfer the measurement data to a PC before requesting calibration.
- Please do not peel off the sticker stuck on the back of the main unit. If you peel it off, all warranty will be invalid.







# Safety Indications

Warnings and Cautions are indicated on this instrument and in the instruction manual to prevent injury to users and others, prevent damage to property or the like, and to ensure safe use of this instrument. After fully understanding the following indications and symbols, carefully read the section "Safety Precautions," and observe all precautions.

Display	Meaning
 <b>Warning</b>	Ignoring this display might result in death or severe injury.
 <b>Caution</b>	Ignoring this indication might result in injury <sup>*1</sup> , or physical damage <sup>*2</sup> .

\*1: This refers to injury such as burns, electric shock or the like that does not require hospitalization or long-term medical attention.

\*2: Physical damage includes damage to the building, property, pets or the like.

Icons	Meaning
	This indicates Hazard Alert (Warning). Specific content is expressed with words or an image located close to the icon. (Example:  Be careful about an electric shock.)
	This icon indicates Prohibition. Specific content is expressed with words or an image located close to the icon. (Example:  Don't touch the operating unit.)
	This icon indicates Mandatory Action. Specific content is expressed with words or an image located close to the icon. (Example:  Install earth ground.)

# Safety Precautions



## Warning



Prohibited

**Do not use this instrument near flammable or combustible gases (gasoline, etc.).**

Failure to do so might cause fire.



Prohibited

**Keep the instrument away from water and liquid.**

Doing so could cause fire or electric shock.



Prohibited

**Do not disassemble or modify this instrument.**

Doing so might cause fire or electric shock.



Mandatory

**Be sure to use the supplied AC adapter or a separately sold and authorized AC adapter.**

AC adapter malfunctions may result in fire or electric shock.



Prohibited

**Do not disassemble the AC adapter.**

Doing so might cause fire or electric shock.



Mandatory

**Remove dust or moisture from the AC adapter plug.**

Failure to do so might cause fire.



Mandatory

**If you notice strange noise, smell or smoke from this instrument, immediately turn the instrument OFF and unplug the AC adapter from the power outlet.**

Continued use of this instrument in this state might cause fire.



## Caution



Prohibited

**Do not look directly at bright lights such as the sun or light bulb filaments.**  
Doing so might damage your eyes.



Prohibited

**Do not place this instrument on an unstable stand or uneven surface.**  
Failure to do so might cause the instrument to fall or tip over.



Prohibited

**Do not plug in or unplug the AC adapter with wet hands.**  
Doing so might cause electric shock.



Mandatory

**Use only specified screws when using the tripod screw and screw holes for jig attachment.**  
Do not tighten the screws any more than necessary. Doing so might cause internal breakage.

## Escape Clauses

- TechnoOptis does not assume any liability for damage to this instrument resulting in fire, earthquake, actions of a third party, other accidents occurring due to negligence of the user, unauthorized use, or other abnormal conditions.
- TechnoOptis does not assume any liability due to collateral damage (loss of business profit, interruption of work, etc.) from the use of or inoperability of this instrument.
- TechnoOptis does not assume any liability for damage that occurs due to use other than that explained in this instruction manual.
- TechnoOptis does not assume any liability for damage that occurs due to malfunctioning or the like resulting from combined use with connected equipment.

## User Maintenance

To maintain safety and performance, any maintenance work other than that explained in this instruction manual should be performed only by a qualified service representative. The following maintenance, however, can be performed by the user.

### Cleaning the Cover and Lens

When the cover or lens becomes dirty, wipe the case or lens with a soft cloth that has been dampened with mild detergent, and then dry with a dry soft cloth.

Do not use solvents such as paint thinner, benzene, acetone or the like. Doing so may discolor the surface.

### Cleaning the Fan motor Filter

A dustproof filter has placed to fan motor on the main body side. When dust adheres to this filter, internal heat radiation is hindered. Please wash the filter regularly with the mild detergent.

# Table of Contents





- Introduction.....1
- Safety Indications.....2
- Safety Precautions .....3
- Notation Rules Used in This Manual.....7
- 1.Before use.....8**
  - 1.1 Main body and accessories.....8
  - 1.2 Names and functions of parts.....9
  - 1.3 Preparation ..... 15
- 2. Measurement Procedure.....19**
  - 2.1 Display of measured value ..... 19
  - 2.2 How to use Analogue output connector ..... 20
  - 2.3 Measuring Light Source With Directivity..... 23
  - 2.4 Using the Instrument in Another System..... 23
- 3. Settings.....24**
  - 3.1 Function mode ..... 24
    - 3.1.1 Enter and escape from the function mode.....24
    - 3.1.2 Setting Menu / Confirm setting data.....24
    - 3.1.3 Menu List.....25
  - 3.2 Detail of Function mode ..... 27
    - 3.2.1 Specify average number .....27
    - 3.2.2 Measurement Range.....28
    - 3.2.3 Filter selection .....30
    - 3.2.4 Correction factor .....31
    - 3.2.5 Sensitivity mode .....39
    - 3.2.6 LAN Parameter.....39
    - 3.2.7 RS-232C Parameter .....40
    - 3.2.8 Auto calibration.....40
    - 3.2.9 Buzzer.....41
    - 3.2.10 Warm-up.....41
- 4. Communication to PC.....42**
  - 4.1 Communication command..... 42
  - 4.2 Command list..... 42
  - 4.3 Communication Protocol ..... 44
    - 4.3.1 RM Command.....44

4.3.2	LM Command.....	44
4.3.3	CAL Command.....	45
4.3.4	WHO Command.....	45
4.3.5	VER Command.....	45
4.3.6	SRL Command.....	46
4.3.7	ST Command.....	46
4.3.8	MV_# Command.....	47
4.3.9	AV_# Command.....	49
4.3.10	MG_# Command.....	49
4.3.11	SR_# Command.....	50
4.3.12	FO_# / FX_# / FY_# / FZ_# Command.....	50
4.3.13	MF_# Command.....	50
4.3.14	FS_# Command.....	51
4.3.15	FG Command.....	51
4.3.16	WF_# #####_#####_##### Command.....	51
4.3.17	RF_# Command.....	52
4.3.18	CF_# Command.....	52
4.3.19	BR_# Command.....	52
4.3.20	DM_# Command.....	53
4.3.21	LIS_###.###.###.### Command.....	53
4.3.22	LIG Command.....	53
4.3.23	LMS_###_###_###_### Command.....	54
4.3.24	LMG Command.....	54
4.3.25	LPS_##### Command.....	54
4.3.26	LPG Command.....	55
4.3.27	PMT Command.....	55
4.3.28	ERR Command.....	55
4.4	Output format.....	56
4.5	Error Code List.....	57
<b>Appendix.....</b>		<b>59</b>
Specification.....		59
Block Diagram.....		63
External Dimension.....		64
Internal Calculation Processing.....		65
Terminology.....		66

# Notation Rules Used in This Manual

---

The following notation rules are used in this manual.

Notation	Explanation
[MODE], [UP]	Indicates panel switches or titles of screens displayed on the display.
	Indicates a reference location in the manual.
	Indicates another manual used as a reference.
 <b>Request</b>	Indicates items to keep in mind when performing an operation, or items that require attention.
 Memo	Indicates items to consider when performing an operation or information that is useful.

# 1. Before use

## 1.1 Main body and accessories

---

Before using, check that all the following items have been included with your instrument. If anything is missing, please contact your dealer or TechnoOptis.

- RD-80SA Main body 1
- Objective lens cap 1
- Eyepiece lens cap 1
- Dedicated AC adapter 1
- CD-ROM (Instruction manual) 1
- BNC cable 1
- Inspection report 1

# 1.2 Names and functions of parts

## ■ Names of each parts

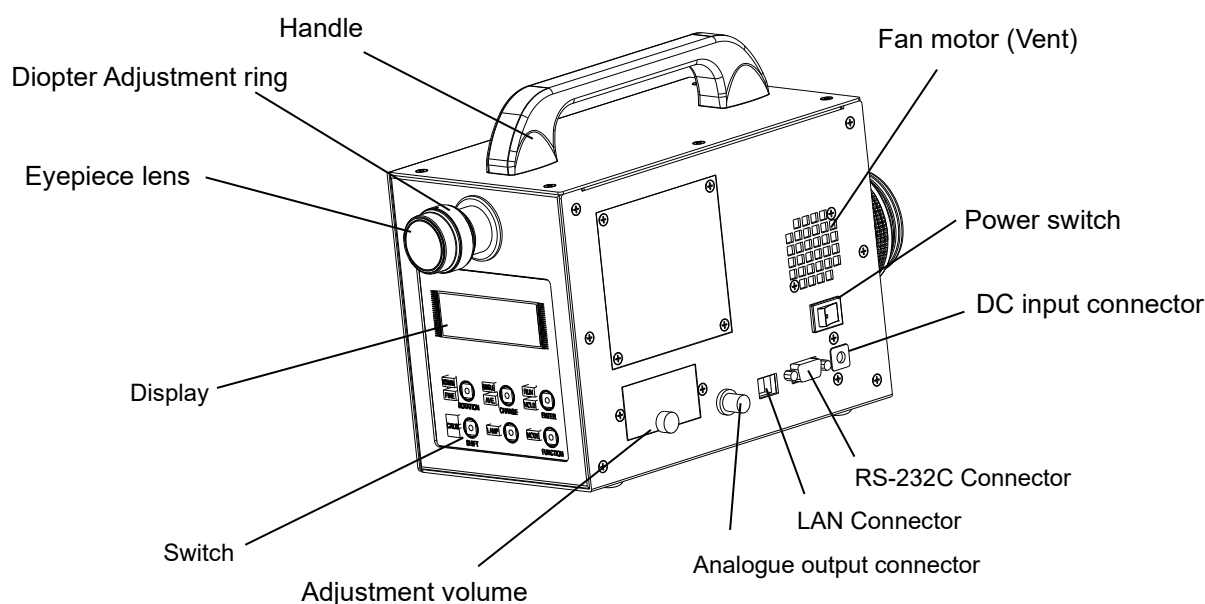

Name	Function
Diopter Adjustment Ring	Adjusts the focus the eyepiece lens on the reticle mark.
Display	Displays measured data, measuring condition data, and various information
Switch	Operates measurement. These switches are used in function mode also. ☞ 「■Names and functions of Switch」
LAN connector	Connects LAN Cable when communicate with PC in remote mode. ☞ 「1.3 Preparation」
RS-232C Connector	Connects RS-232C cable when communicate with PC in remote mode ☞ 「1.3 Preparation」
Analogue output connector	Connects BNC cable when observing signal voltage. The signal voltage is proportional to the intensity of the light received by photo detector in the instrument. ☞ 「2.2How to use Analogue output connector」
Power Switch	Power Switch
DC Input Connector	Connects dedicated AC adapter.
Adjustment Volume	Volumes for adjustment in the cover.

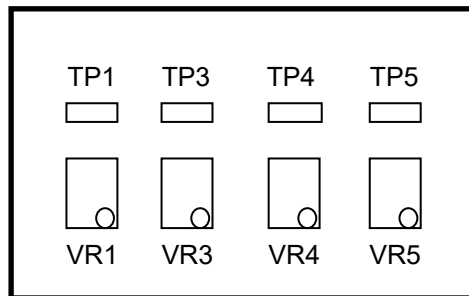
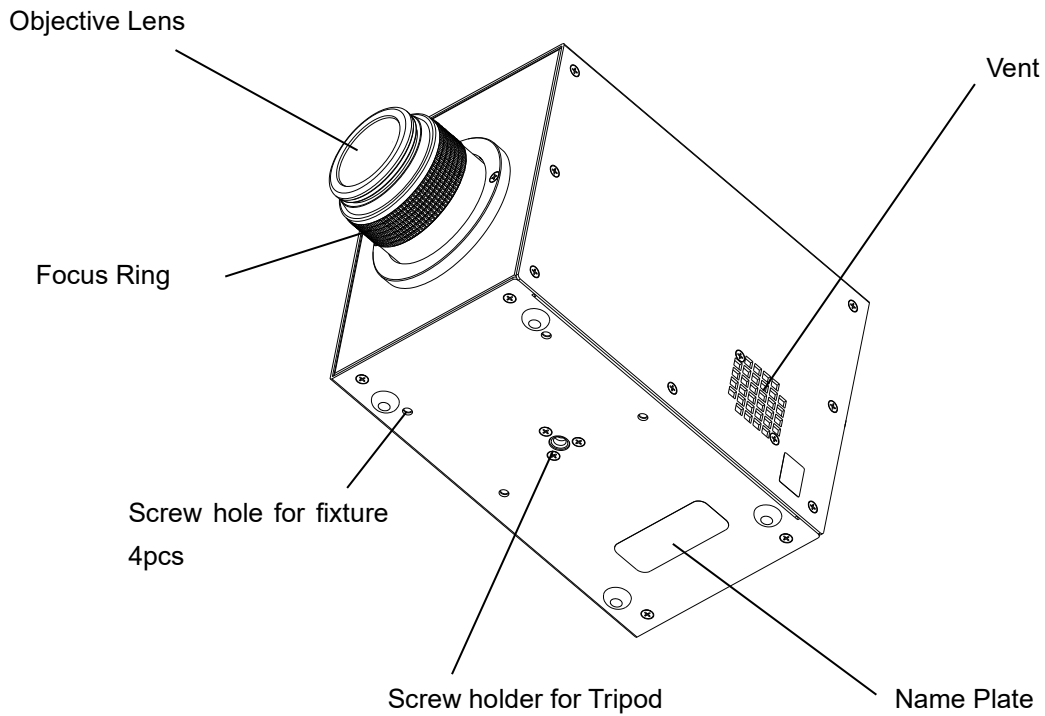

Adjustment volume

Name	Function
Focus Ring	Adjusts focus of objective lens.
Screw hole for Tripod	Screw hole for Tripod. Screw hole comply with JIS B 7103-1975 (the same as the standard for the camera) Nominal size :1/4-20UNC The number of thread:20 Pitch :1.270 mm Depth :6 mm
Screw hole for fixture	Uses to fix the instrument to stand a base. M4×0.7 (φ4, Pitch:0.7 mm)

☞ 「Appendix」

 <b>Request</b>	Use only specified screws when using the tripod screw and screw holes for jig attachment. Do not tighten the screws any more than necessary. Doing so might cause internal breakage.
-------------------------------------------------------------------------------------------------------	--------------------------------------------------------------------------------------------------------------------------------------------------------------------------------------

## ■ Names and Functions of switch

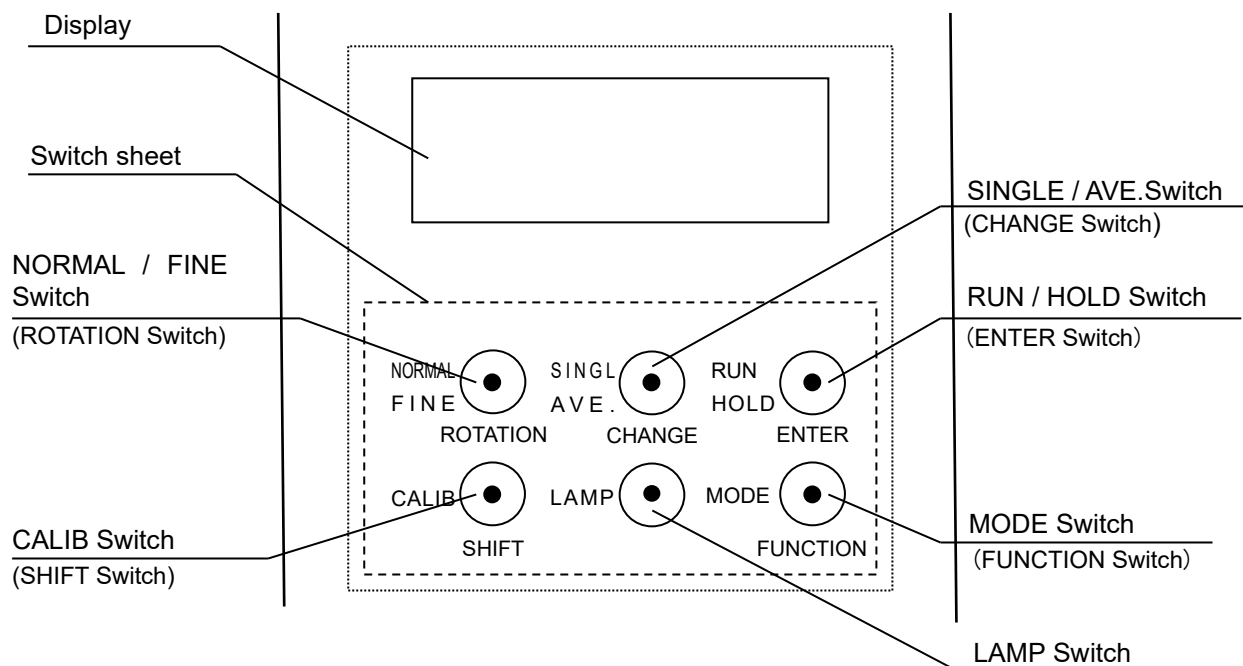

Switch has two functions as follows;

- For measurement (Functions are inscribed on left of each switch)
- For setting in function mode (Functions are inscribed on below of each switch)

### Functions in measurement

Name	Function
NORMAL/FINE Switch	Changes the range setting in MANUAL range mode. NORMAL : ALL RANGE。 FINE : EACH RANGE ☞ 「3.2.2 Measurement Range」
SINGLE/AVE. Switch	Sets ON/OFF of the Average measurement. SINGLE : Average measurement is OFF AVE : Average measurement is ON The instrument measure repeatedly for a specified number of iterations. The results are averaged over specified repetitions of the measurement.
RUN/HOLD Switch	Starts / Stops measurement
CALIB Switch	Starts calibration of the photo detector. The calibration serves to maintain the sensitivity of the photo detector and stability of measured data.
LAMP Switch	ON/OFF backlight of the display
MODE Switch	Selects color space. Press this switch to change color space in Hold status (turning on [HOLD] LED).

Function in Function mode

Name	Function
FUNCTION Switch	Enters and escapes from Function mode. Keep the switch pressed for 2 seconds to enter function mode. Press this switch to escape from the function mode.
ENTER Switch	Changes the display menu and confirms new settings.
CHANGE Switch	Changes settings in function mode and moves the cursor down digit when inputting numerical value. <ul style="list-style-type: none"> <li>▪ When press this switch, the cursor blink and able to enter new numerical data.</li> </ul>
ROTATION Switch	Each time pressing this switch, options are shown in sequence on display.
SHIFT Switch	Moves the cursor up digit when inputting numerical value.

## ■ Indication of Display

Following message appears when turn on power

```
** Start RD-80SA **  
** Ver 1.00 **
```

- Initialization

The RD-80SA starts initialization of the system after turning on power  
It takes about 60seconds to complete the initialization.

```
Please wait...  
60 seconds
```

- Warm-up

Photo detector warms up.

```
During Aging  
60 minutes
```

- Calibration

Photo detector is calibrated

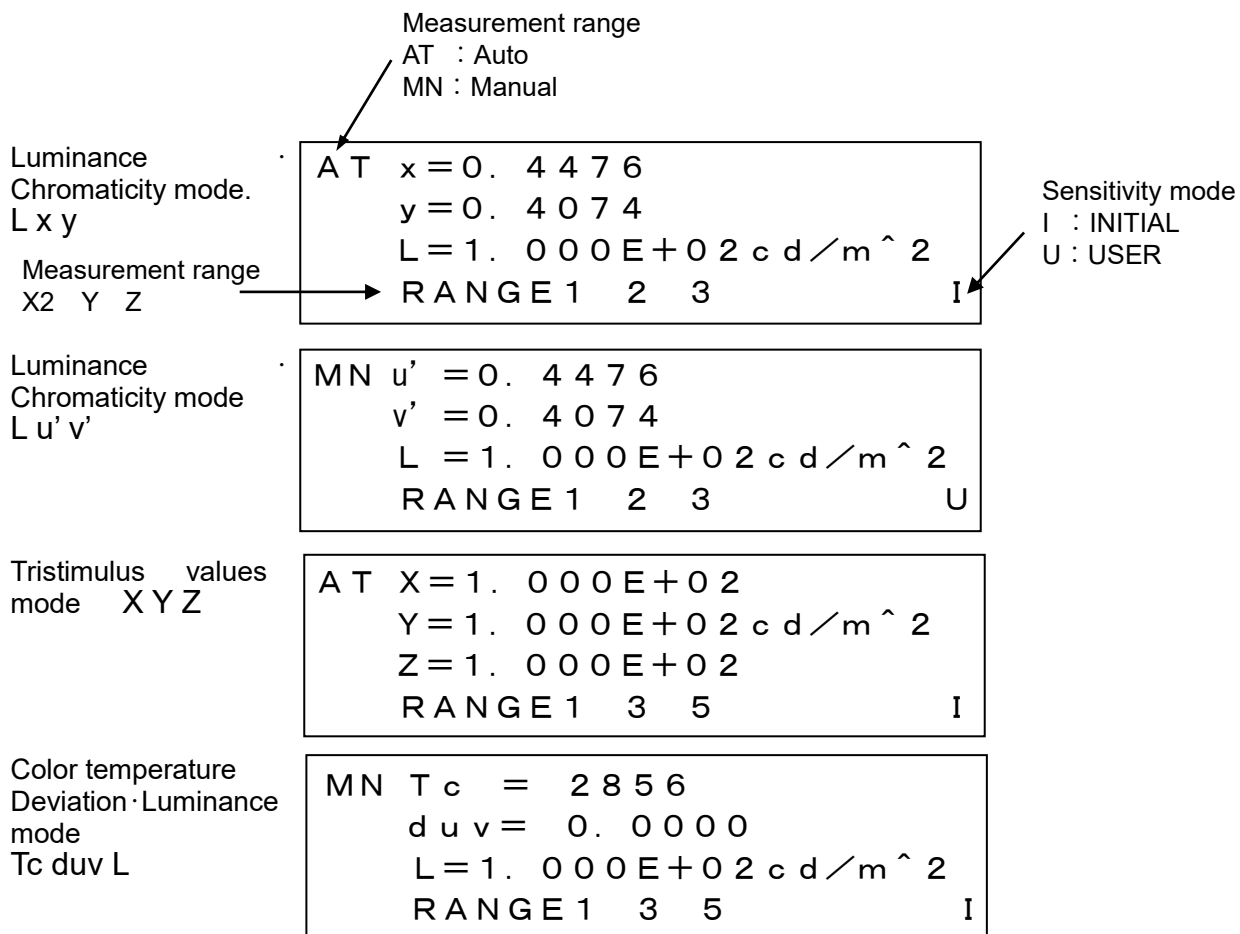

```
Calibrating
```

• Display of Measured data



# 1.3 Preparation

## ■ Connecting AC adapter

 Mandatory	<b>Be sure to use the supplied AC adapter or a separately sold and authorized AC adapter.</b> AC adapter failure may result in fire or electric shock.
 Mandatory	<b>Remove dust or moisture from the AC adapter plug.</b> Failure to do so might cause fire.
 Prohibited	<b>Do not plug in or unplug the AC adapter plug with wet hands.</b> Doing so might cause electric shock.

Connection procedure

- 1 Confirm the power is OFF

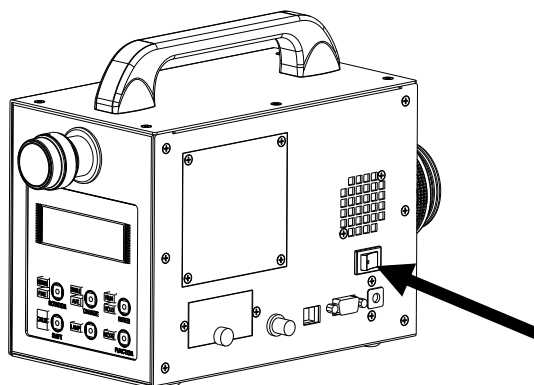

- 2 Connect the AC adapter plug to the DC input connector

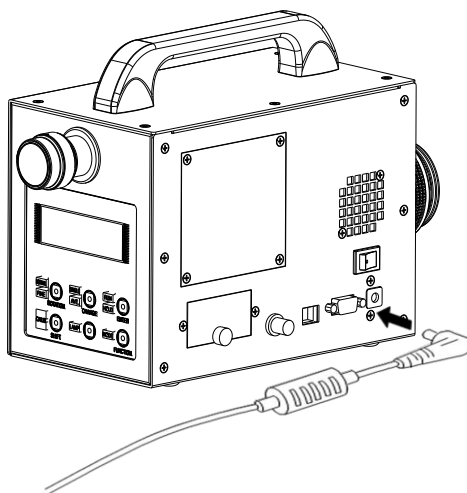

3 Plug the AC adapter to outlet.

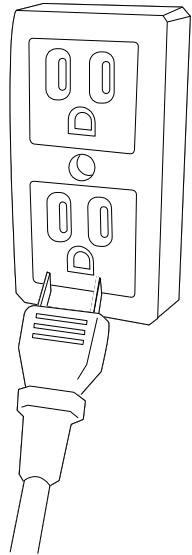



### ■ Connecting the PC

The RD-80SA can connect PC with RS-232C or LAN cable. Use RS-232C cable with Interlink cable of serial cross type supporting for a DOS/V PC. Or use LAN cable category 5 or greater and straight type.

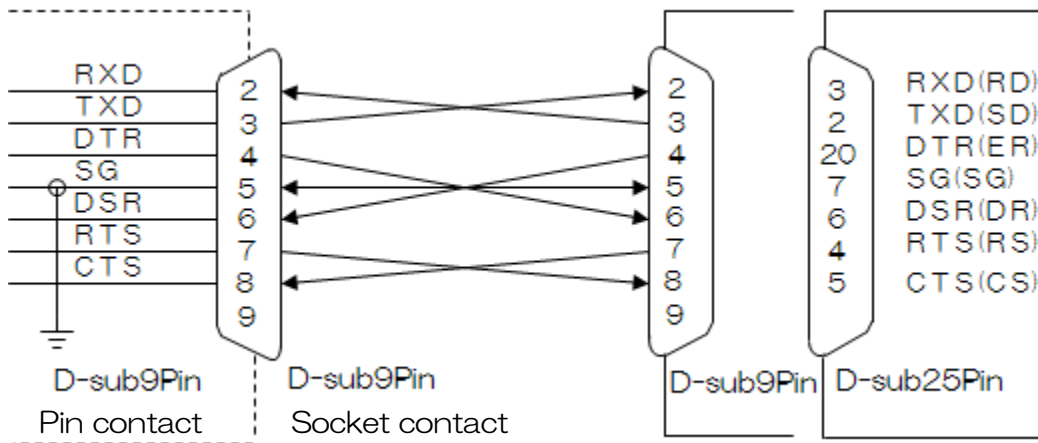
The RS-232C signal line of the instrument is arranged according to the 9 pin D-sub being used in the DOS/V PC.



 <b>Notice</b>	<p>The RD-80SA can connect RS-232C and LAN cable together.          But do not use both communications at the same time, otherwise the system may be unstable.</p>
------------------------------------------------------------------------------------------------------	------------------------------------------------------------------------------------------------------------------------------------------------------------------------

 Memo	<ul style="list-style-type: none"> <li>• RS-232C and LAN cable are not included in standard package of the RD-80SA.</li> <li>• About communication setting in PC, refer to instruction manual of the PC.</li> </ul>
------------------------------------------------------------------------------------------	---------------------------------------------------------------------------------------------------------------------------------------------------------------------------------------------------------------------

## ■ RS-232C specification

Parameters other than Baud rate and Delimiter are invariable.

- Communication method :Full duplex
- Synch method :Start-stop transmission
- Baud rate :9600/19200/38400 bps (Bits Per second)
- Data length :7 bit
- Parity :ODD
- Stop bit : 1 bit
- Communication format :Text (ASCII)
- Delimiter :”CR+LF” or “CR” is appended to the end of the communication data row

## ■ LAN (TCP/IP) specification

- Ethernet 10 /100 Base-TX

When connect PC, set following parameter in the function mode.

- LAN communication parameter setting Refer to  「3.2.6 LAN Parameter」
- RS-232C communication parameter setting Refer to  「3.2.7 RS-232C Parameter」

## ■ Object collimation

 Prohibited	<b>Do not look at directly bright light such as the Sun and the filament lamp, otherwise it cause damage to eye.</b>
---------------------------------------------------------------------------------------------------	----------------------------------------------------------------------------------------------------------------------

 Request	Use only specified screws when using the tripod screw and screw holes for jig attachment. Do not tighten the screws any more than necessary. Doing so might cause internal breakage.
------------------------------------------------------------------------------------------------	--------------------------------------------------------------------------------------------------------------------------------------------------------------------------------------

- 1 Fix the instrument to stand such as tripod.
- 2 Remove the objective lens cap.
- 3 Open the finder shutter.
- 4 Look into the eyepiece and turn the diopter adjustment ring to focus on the reticle Mark.

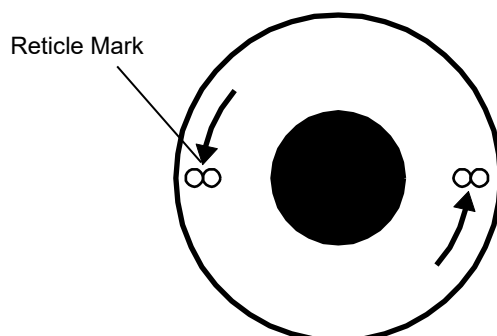

- 5 Collimate with the object and turn the focus ring of objective lens to focus on the object.

## ■ Turn Power ON / OFF

 <b>Request</b>	Warm-up start after turn on power. We recommend that warm-up conduct 60 minute for high accuracy measurement. Press [RUM] switch to cancel Warm-up.
-----------------------------------------------------------------------------------------------------	--------------------------------------------------------------------------------------------------------------------------------------------------------

### • Power ON

Flip the power switch to right to turn on power.

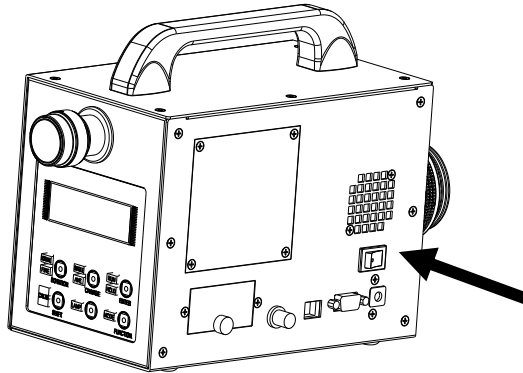

### • Power OFF

Flip the power switch to left to torn off power.

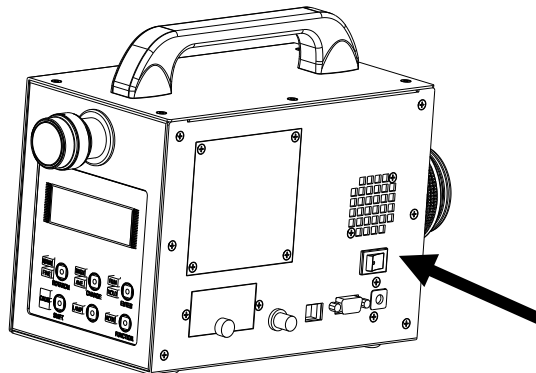

# 2. Measurement Procedure

## 2.1 Display of measured value

Measured values are expressed in various units. The units is selectable by pressing [MODE] switch during Hold status ([HOLD] switch lighting on)

Luminance  
·Chromaticity mode  
L x y

```
AT x=0. 4476
   y=0. 4074
   L=1. 000E+02 cd/m^2
   RANGE 1 2 3 I
```



Luminance  
Chromaticity mode  
L u' v'

```
MN u' =0. 4476
   v' =0. 4074
   L =1. 000E+02 cd/m^2
   RANGE 1 2 3 U
```



Tristimulus values  
mode  
XYZ

```
AT X=1. 000E+02
   Y=1. 000E+02 cd/m^2
   Z=1. 000E+02
   RANGE 1 3 5 I
```



Color Temperature  
Deviation  
Luminance mode  
Tc duv L

```
MN Tc = 2856
   duv = 0. 0000
   L=1. 000E+02 cd/m^2
   RANGE 1 3 5 I
```

※The display shows [\*\*\*\*\*] in measured data and range data in all mode until after first measurement

## 2.2 How to use Analogue output connector

The variation in brightness such as building-up time, falling-down time, and frequency can be measure by connecting the oscilloscope.

Select one filter from  $X_2$ , Y, Z Tristimulus values filter or No Filter. And pull out analogue signal from the photo detector via analogue output connector.

### ■Relation between Analogue voltage and Luminance

The output voltage range in each measurement range is from 0.05V to 3V (default).  
Readout data of Luminance have relation with analogue output voltage as following table.

RANGE	Measurable range (cd/m <sup>2</sup> )		
Range 1	0.1	—	5
Range 2	0.5	—	15
Range 3	1.5	—	40
Range 4	3.5	—	120
Range 5	15	—	600
Range 6	35	—	1600
Range 7	220	—	2900
Range 8	750	—	10000

 <b>Notice</b>	<ul style="list-style-type: none"><li>• The correlation function between the Analogue output voltage and the luminance value vary from instrument to instrument. When you determine luminance value from the analog output voltage, check the correlation function beforehand.</li><li>• When you select [USER] in sensitivity setting, above list is not adopted.</li></ul>
------------------------------------------------------------------------------------------------------	------------------------------------------------------------------------------------------------------------------------------------------------------------------------------------------------------------------------------------------------------------------------------------------------------------------------------------------------------------------------------

## ■ Adjustment Volume

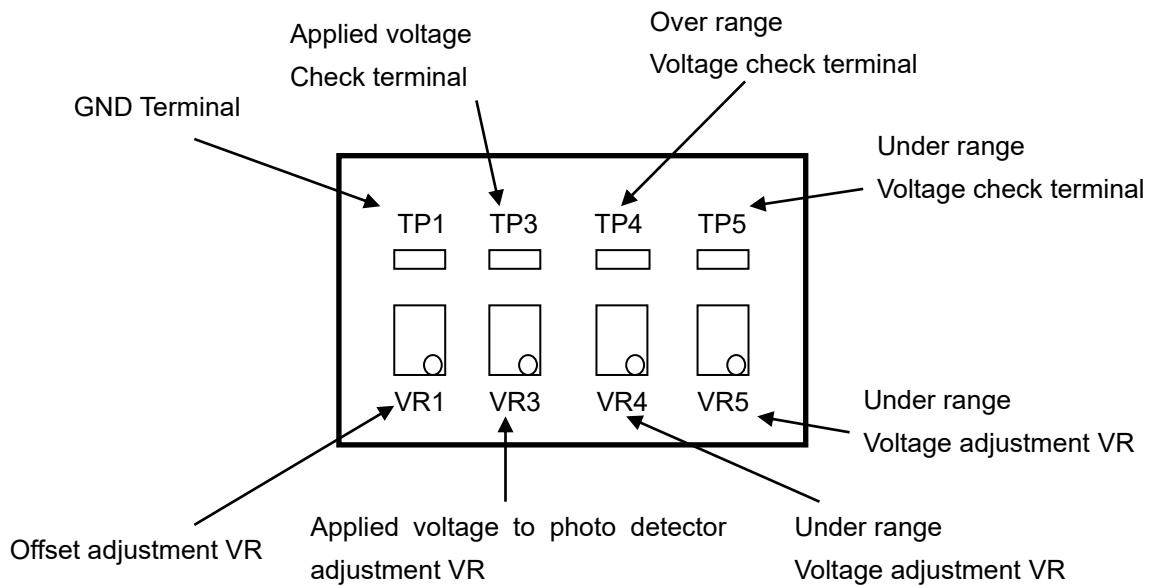

### —Offset adjustment VR1

The Volume for output analogue voltage adjustment

Adjustable range : about  $\pm 1.0V$

Default value : 0.05V

### —Applied voltage to photo detector adjustment VR3

Adjusts the applied voltage to the photo detector (Photo Multiplier Tube)

Sensitivity of detector can be changed.

Adjustable range : about 0V - 1.0V

Stronger voltage makes sensitivity higher.

※When you keep on setting high sensitivity, the life of detector shorten. Please set the voltage from 0.3V to 0.5V.

### —Over range Voltage adjustment VR4

The voltage level which generate over range error can be adjusted.

Adjustable range : 2.0V - 3.4V

Default value : 3.3V

### —Under range Voltage adjustment VR5

The voltage level which generate under range error can be adjusted.

Adjustable range : 0V - 1.2V

Default value : 0.03V

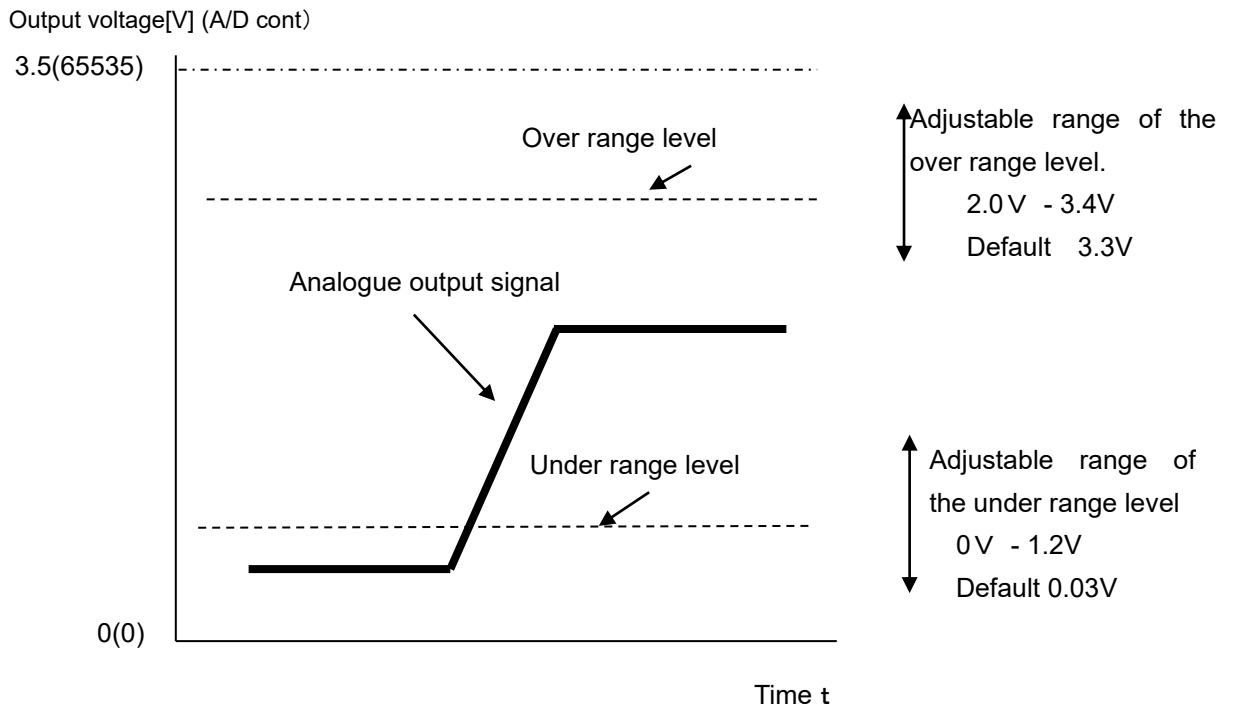

When analogue output voltage rise to the over range level, the over range error occur.  
When analogue output voltage fall down to the under range level, the under range error occur

## ■ Usage

The procedure of use analogue output

- 1 Connect dedicated BNC cable to the RD-80SA.
- 2 Press [RUN/HOLD] switch to start measurement.



Memo

Analogue output voltage is provided during RUN status.



Notice

- When over range error occur, the instrument cannot provide accurate data. Be sure to set appropriate measurement range.
- Impedance :100Ω or less

## 2.3 Measuring Light Source With Directivity

---

Data having good reproducibility sometimes cannot be obtained when observing a light source with high directivity such as an LED or an uneven light source. If this happens, perform measurement using a white board as shown below.

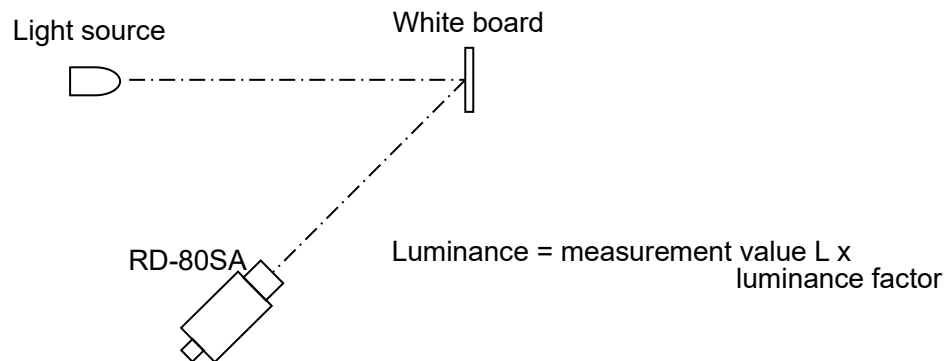

## 2.4 Using the Instrument in Another System

---

When using the instrument in another system such as an XY stage, install it on the system using the jig attachment screws on the base of the instrument.

Also, connect the instrument to a PC using the RS-232C or USB interface.

When using the unit in a system, refer to the following.

- ☞ 「4. Communication with a PC 」
- ☞ 「Appendix: External Dimensions」

# 3. Settings

## 3.1 Function mode

You can change and confirm the setting and the parameter in function mode.

### 3.1.1 Enter and escape from the function mode

Press [FUNCTION] switch to enter and escape from the function mode.

#### ■ Enter function mode

- 1 Confirm that the instrument is in HOLD status.
- 2 Press [FUNCTION] switch for 2 seconds to enter the function mode.

 「3.1.2 Setting Menu/Confirm setting data」

#### ■ Escape from the function mode

Press [FUNCTION] switch to escape from the function mode and return to the measurement mode.

 Memo

When escaping from the FUNCTION mode, press the [FUNCTION] switch, need not to press and hold the [FUNCTION] switch.

### 3.1.2 Setting Menu / Confirm setting data

Each time you press [ENTER] switch in the function mode, the item in the menu change to the next. Press [ENTER] switch until the appropriate item appear.

Each item is described as below;

- |                     |                                                                                                               |
|---------------------|---------------------------------------------------------------------------------------------------------------|
| • Average measure   |  「3.2.1 Average number」    |
| • Measurement range |  「3.2.2 Measurement range」 |
| • Filter selection  |  「3.2.3 Filter selection」  |
| • Correction factor |  「3.2.4 Correction factor」 |
| • Sensitivity mode  |  「3.2.5 Sensitivity mode」  |
| • LAN parameter     |  「3.2.6 LAN Parameter」     |
| • RS-232C parameter |  「3.2.7 RS-232C parameter」 |
| • Auto calibration  |  「3.2.8 Auto calibration」  |
| • Buzzer            |  「3.2.9 Buzzer」            |
| • Warm-up           |  「3.2.10 Warm-up」          |

### 3.1.3 Display in Function mode menu

---

Display for each item in function mode is as follows.

Each time you press [ENTER] switch, change to next item.

#### ■Average number

Specify the number of measurement. Measured data are averaged from specified number of measurement.

☞ 「3.2.1 Specify average number」

```
*  AVERAGE MEASURE  *  
      AVERAGE  5
```

#### ■Measurement range

Select Auto range (AUTO) or Manual range (MANU)

☞ 「3.2.2 Measurement range」

```
*  AUTO / MANUAL  *  
      AUTO
```

#### ■Filter selection

Select filter from OPEN\_ONLY / X2\_ONLY / LUMINANCE ONLY / Z\_ONLY / CHROMATICITY

☞ 「3.2.3 Filter selection」

```
*  FILTER SELECT  *  
      OPEN_ONLY
```

#### ■Correction factor

Sets correction factor number

☞ 「3.2.4 Correction factor」

```
*  FACTOR NUMBER  *  
      SET FACTOR OFF
```

#### ■Sensitivity mode

Select a sensitivity mode from INITIAL(Default) / USER(user-configuration)

☞ 「3.2.5 Sensitivity mode」

```
*  PMT SENS  *  
      INITIAL
```

#### ■LAN Parameter

Set LAN interface parameter

☞ 「3.2.6 LAN Parameter」

```
*  LAN PARAMETERS *  
IP=192.168.100.1  
SUB=255.255.255.255  
PORT=50000
```

#### ■RS-232C Parameter

Set RS-232C interface parameter

☞ 「3.2.7 RS-232C Parameter」

```
*RS-232C PARAMETERS*  
Baud rate=38400  
DELIMITER=CRLF
```

■ Auto Calibration

On or Off of auto calibration of photo detector

☞ 「3.2.8 Auto Calibration」

\* AUTO CALIBRATION \*

ON

■ Buzzer

On or Off buzzer sound

☞ 「3.2.9 Buzzer」

\* BUZZER ON/OFF \*

ON

■ Warm-up

Conducts warm-up of photo detector

☞ 「3.2.10 Warm-up」

\* PMT AGING \*

SHIFT : START

## 3.2 Detail of Function mode

---

### 3.2.1 Specify average number

---

When you select [AVE] in [SINGLE/ AVE] switch in the measurement mode, The RD-80SA measure repeatedly for a specified number of iterations and calculate the average of measured value over specified repetitions of the measurement. This describe that the procedure to specify the number of measurement.

The number of measurement can be specified from 2 to 20.

☞ 「1.2 Names and functions of parts」

☞ 「3.1.2 Setting Menu / Confirm setting data」

```
*   A V E R A G E   M E A S U R E   *  
  
      A V E R A G E   5
```

- 1 Press [CHANGE] switch
- 2 Press [ROTATION] switch to select options.  
Each time you press [ROTATION] switch, the number is changed as follows;  
2 → 3 → ..... → 20 → 2 .....
- 3 After specify the number, press [ENTER] switch to confirm.

## 3.2.2 Measurement Range

---

Selects measurement range depend on brightness of light source



**AUTO** : The instrument automatically select optimum measurement range for light source.

**MANUAL** : Specifies measurement range manually

 「3.1.2 Setting Menu / Confirm setting data」

- 1 Press [CHANGE] switch
- 2 Press [ROTATION] switch to select options.  
Each time you press [ROTATION] switch, the option changes between [AUTO / MANUAL].
- 3 Press [ENTER] switch after selection

### 3.2.2.1 AUTO range setting

There are three type of the AUTO range. This described how to set each AUTO range setting.

- 1 Current measurement range setting appears.



- 2 Set to [AUTO] by pressing [ROTATION] and[CHANGE] switch.



- 3 After pressing [ENTER] switch, following screen appears.



- 4 Press [ROTATION] switch to select one option in AUTO range type from followings.  
**AUTO FULL** : Automatically set optimum measurement range at each measurement.  
**AUTO FIRST** : Automatically set optimum measurement range at first measurement only.  
**AUTO ADJUST** : Automatically set optimum measurement range at first measurement and over/under error occur.

### 3.2.2.2 Manual range setting

There are two type of the Manual range. This described how to set each Manual range setting.

- 1 Current measurement range setting appears

```
*      A U T O  /  M A N U A L      *  
  
      A U T O
```

- 2 Set to [MANUAL] by pressing [ROTATION] and[CHANGE] switch

```
*      A U T O  /  M A N U A L      *  
  
      M A N U A L
```

- 3 After pressing [ENTER] switch, following screen appears.

```
*      M A N U A L  R A N G E      *  
  
      A L L  R A N G E  1
```

- 4 Press [ROTATION] switch to select one option from followings.

ALL RANGE : The same measurement range is set to each OPEN / X2 / Y / Z filter.  
Press [ROTATION] switch to increment measurement range until appropriate measurement range.

EACH SELECT : The measurement range are set to each OPEN / X2 / Y / Z filter separately.

- The procedure to set measurement range for each OPEN / X2 / Y / Z separately

- 1 When [EACH SELECT] appear , Press [CHANGE] switch.

```
*      M A N U A L  R A N G E      *  
  
      E A C H  S E L E C T
```

- 2 After following screen appears, Set appropriate measurement range at each filter by using [CHANGE] and [ROTATION] switch. And press [SHIFT] switch to move the cursor to another filter.

```
*      M A N U A L  E A C H      *  
  
O P E N  R = 1      X 2  R = 2  
  Y  R = 3      Z  R = 4
```

3 Press [ENTER] switch to return to menu screen in function mode and setting takes effective.

 Memo

- Setting in ALL RANGE takes effect when selecting [NORMAL] of [NORMAL / FINE] switch.
- Setting in EACH SELECT takes effect when selecting [FINE] of [NORMAL/FINE] switch.

 「1.2Names and functions of parts」

### 3.2.3 Filter selection

---

Sets filter from options.

```
*   F I L T E R   S E L E C T   *  
  
C H R O M A T I C I T Y
```

OPEN_ONLY	:	No filter	
X2_ONLY	:	X2 filter only	
LUMINANCE ONLY	:	Y filter only	(Luminance measurement)
Z_ONLY	:	Z filter only	
CHROMATICITY	:	X2/Y/Z filter	(Luminance / Chromaticity measurement)

The procedure for changing setting is as follows;

- 1 Press [CHANGE] switch
- 2 Press [ROTATION] switch to select option.  
Each time you press [ROTATION] switch, option on display change as follows;  
OPEN\_ONLY→X2\_ONLY→LUMINANCE ONLY→Z\_ONLY→CHROMATICITY →  
OPEN\_ONLY .....
- 3 After selecting, press [ENTER] switch.

## 3.2.4 Correction factor

---

The RD-80SA can apply correction factor to measured data and compensate for error. There are two ways to enter correction factor as follows;

- 1 When correction factors KX, KY, KZ are found beforehand, Enter them via panel switch by manually.
- 2 When reference luminance value and chromaticity value are found, enter them via panel switch and measures the object. The RD-80SA calculate correction factor KX, KY, KZ from reference data and measured value.

Correction factor are calculated by using following formula;

$$X' = X \times KX$$

$$Y' = Y \times KY$$

$$Z' = Z \times KZ$$

X' / Y' / Z' : Tristimulus values applied correction factor to

X / Y / Z : Measured data of object in Tristimulus values

KX / KY / KZ : Correction factors in Tristimulus values

Select following screen in function mode



*    F A C T O R   N U M B E R    *
S E T   F A C T O R   O F F

 「3.1.2 Setting Menu / Confirm setting data」

### 3.2.4.1 Screen in Correction factor setting

After press [CHANGE] switch, following screen appears.

F A C T O R	
D I S P & S E T	O F F
I N P U T	* B A C K
C L E A R	

- DISP&SET : Select this item to confirm the value of correction factor in K01 - K10.  
 「3.2.4.3 Check and set of correction factor」
- INPUT : Select this item to enter or change correction factor.  
 「3.2.4.2 Entry correction factor」
- CLEAR : Select this item to delete correction factor.  
 「3.2.4.4 Delete correction factor」
- OFF : Select this item to disable correction factor.
- BACK : Select this item to return to former screen.

Press [ROTATION] switch to move cursor [ \* ].

Press [ENTER] switch to enter this item and go to next screen.

The procedure to reach this screen is as follows;

- 1 Select following screen in the function mode.

* F A C T O R N U M B E R *
S E T F A C T O R O F F

- 2 After pressing [CHANGE] switch, following menu screen appear.

F A C T O R	
D I S P & S E T	O F F
I N P U T	* B A C K
C L E A R	

 「3.2.4.2 Entry correction factor」

### 3.2.4.2 Entry correction factor

The procedure for entry correction factor is as follows;

- 1 Select following screen in the function mode.

```
*   FACTOR NUMBER   *  
  
   SET FACTOR OFF
```

- 2 Press [CHANGE] switch and following screen appear.

```
FACTOR  
DISP&SET      OFF  
INPUT         *BACK  
CLEAR
```

- 3 Press [ROTATION] switch to move cursor [ \* ] to [INPUT].

```
FACTOR  
DISP&SET      OFF  
* INPUT       BACK  
CLEAR
```

- 4 Press [ENTER] switch and following screen appears.

```
K 0 1  
  
   NO DATA  
  
R=NEXT S=PAGE
```

Press [ROTATION] switch to select correction factor data from recorded data.

Example we enter correction factor number to be "01".

(R=NEXT : [ROTATION]、 S=PAGE : [SHIFT])

- 5 Press [CHANGE] switch and following menu screen appears.

```
FACTOR INPUT  
DIRECT  
REF. & MEASURE  
*BACK
```

—DIRECT

Select this item to enter correction factor KX, KY, KZ directly.

—REF. & MEASURE

Select this item to enter reference luminance/chromaticity data, and measure the object in order to calculate correction factor in the RD-80SA.

—BACK

Select this item to return to former screen.

There are two ways to enter correction factors.

■ **Direct entry of correction factor KX, KY, KZ**

- 1 Press [ROTATION] switch to move the cursor [\*] to [DIRECT] and then, press [ENTER] switch.

```
FACTOR INPUT
*DIRECT
REF. & MEASURE
BACK
```

- 2 Correction factor entry screen appears.

```
K01 DIRECT INPUT
KX= 1.000E+00
KY= 1.000E+00
KZ= 1.000E+00
```

- 3 Press [CHANGE] switch and then cursor blink to be entered.  
Each time you press [ROTATION] switch, figure is changed as follow. Press [SHIFT] switch to move next digit.

. → 0 → 1 → 2 → 3 → 4 → 5 → 6 → 7 → 8 → 9 → + → - → E → . . . . .

- 4 After entering data, press [ENTER] switch to determine the entry.

■ **Entry of reference data and calculate correction factor**

- 1 Press [ROTATION] switch to move the cursor [\*] to [REF.&MEASURE], and then press [ENTER].

```
FACTOR INPUT
DIRECT
*REF. & MEASURE
BACK
```

- 2 Correction factor entry screen appears

```
K01 DIRECT INPUT
x = * * * * *
y = * * * * *
L = * * * * * * *
```

- 3 Press [CHANGE] switch and then, the cursor blink to be entered.  
Each time you press [ROTATION] switch, figure is changed as follow. Press [SHIFT] switch to move to next digit.

. → 0 → 1 → 2 → 3 → 4 → 5 → 6 → 7 → 8 → 9 → + → - → E → . . . . .

- 4 Enter data of  $x, y$ , and  $L$  and then, press [ENTER] switch to determine the entry.  
Then, Press [ENTER] switch and following screen appear.  
Press [RUN/HOLD] switch to measure the object.

```

      A t t e n t i o n  ! !
P l e a s e  s e t
t h e  R e f .  s a m p l e ,  t h e n
p u s h  R U N / H O L D  k e y .

```

- 5 After measuring, the RD-80SA calculate correction factor automatically and the correction factor data appear as follow. Then screen return to FACTOR INPUT MENU screen.

Correction factor calculated by the RD-80SA

```

K 0 1   K X =  1 . 0 0 5 E + 0 0
        K Y =  1 . 0 0 2 E + 0 0
        K Z =  9 . 9 5 2 E - 0 1
        R = N E X T   S = P A G E

```

(R=NEXT : [ROTATION], S=PAGE : [SHIFT])

FACTOR INPUT MENU

```

F A C T O R   I N P U T
D I R E C T
* R E F .   &   M E A S U R E
B A C K

```

- 6 Press [ROTATION] switch to move the cursor [\*] to [BACK] and press [ENTER] switch to return.

```

K 0 1   K X =  1 . 0 0 5 E + 0 0
        K Y =  1 . 0 0 2 E + 0 0
        K Z =  9 . 9 5 2 E - 0 1
        R = N E X T   S = P A G E

```

- 7 Press [SHIFT] switch (S=PAGE) and determine the entry.  
Correction factor KX, KY, KZ

```

K 0 1   K X =  1 . 0 0 5 E + 0 0
        K Y =  1 . 0 0 2 E + 0 0
        K Z =  9 . 9 5 2 E - 0 1
        R = N E X T   S = P A G E

```

Reference data of luminance and chromaticity.

```

R E F 0 1   x =  0 . 4 4 7 6
            y =  0 . 4 0 7 4
            L =  1 . 0 0 0 E + 0 2
            R = N E X T   S = P A G E

```

Measured data of object

```
SMP 0 1  x =  0. 4 4 6 4
          y =  0. 4 0 7 5
          L =  9. 9 8 0 E+0 1
          R=NEXT  S=PAGE
```

8 Press [ENTER] switch to return Correction factor menu screen.

### 3.2.4.3 Check and set of correction factor

Entered correction factor shows. When correction factor is not entered, the RD-80SA shows [NO DATA]. [SET] appears on the screen in applied correction factor.

No correction factor entry

```
K 0 1
      NO DATA
      R=NEXT  S=PAGE
```

Correction factor data

```
K 0 1  KX=  1. 0 0 0 E+0 0
        KY=  1. 0 0 0 E+0 0
        KZ=  1. 0 0 0 E+0 0
C=SET  R=NEXT  S=PAGE
```

Applied correction factor

```
K 0 1  KX=  1. 0 0 0 E+0 0
SET    KY=  1. 0 0 0 E+0 0
        KZ=  1. 0 0 0 E+0 0
C=SET  R=NEXT  S=PAGE
```

Press [CHANGE] switch to determine or cancel.

Details of items

- K01 : Correction factor Number. The RD-80SA can record ten correction factor data.  
K01 - K10
- NO DATA : When no correction factor is entered, this message appear.
- KX / KY / KZ : Correction factor in Tristimulus values.
- C=SET : [CHANGE] switch = SET  
Press [CHANGE] switch to apply the value on the screen to correction factor.  
[SET] appears on the screen in applied correction factor.
- R=NEXT : [ROTATION] switch =NEXT  
Another correction factor appears.
- S=PAGE : [SHIFT] switch=PAGE  
Each time pressing [SHIFT] switch, screen change as follows;  
Reference data → Measured data → Correction factor data → Reference data

### Reference data

Reference data you entered before appear.

```
REF01  x = 0.4476
        y = 0.4074
        L = 1.000E+02
C=SET  R=NEXT  S=PAGE
```

### Measured data

Measured data which the RD-80SA calculate correction factor.

```
SMP01  x = 0.4476
        y = 0.4074
        L = 1.000E+02
C=SET  R=NEXT  S=PAGE
```

Press [ENTER] switch to return to the former screen.

### Memo

[REF01][SMP01] are shown in the upper-left corner of the Reference data screen, Measured data screen are related to correction factor No. Correction factor data in K01 are calculated from the data of the reference data in REF01 and Measured data in SMP01.

### 3.2.4.4 Delete correction factor

The procedure for entry of correction factor is as follows;

- 1 Select correction factor menu screen.

```

FACTOR
DISP&SET      OFF
INPUT         *BACK
CLEAR
    
```

- 2 Press [ROTATION] switch to move the cursor [ \* ] to [CLEAR]. And then, press [ENTER] switch.

```

FACTOR
DISP&SET      OFF
INPUT         BACK
* CLEAR
    
```

- 3 Following screen will appear.

```

FACTOR CLEAR
ALL CLEAR
SELECT CLEAR
* BACK
    
```

Press [ROTATION] switch to move the cursor [ \* ].

ALL CLEAR : All correction factors are deleted.

SELECT CLEAR : Specified correction factors are deleted.

#### ■ [ALL CLEAR]

```

FACTOR CLEAR
ALL FACTOR CLEAR
YES
* BACK
    
```

YES : All correction factors in the memory are deleted.

BACK : Return to the former screen.

#### ■ [SELECT CLEAR]

```

CL01  KX= 1. 000E+00
      KY= 1. 000E+00
      KZ= 1. 000E+00
C=DEL R=NEXT S=PAGE
    
```

[CHANGE] switch : C=DEL Delete the correction factor on the screen.

[ROTATION] switch : R=NEXT Show next correction factor data in the memory.

[SHIFT] switch : S=PAGE Each time you press this switch, the data on the are changed as follow;  
Correction factor data → Reference data →  
Correction factor data...

[ENTER] switch : Return to the former screen.

## 3.2.5 Sensitivity mode

---

Adjusts the sensitivity of the photo detector

```
*      P M T   S E N S      *  
  
      I N I T I A L
```

INITIAL : Default setting

USER : Set the sensitivity to designated value

 「3.1.2 Setting Menu / Confirm setting data」

The procedure for operation is as follows

- 1 Press [CHANGE] switch
- 2 Press [ROTATION] switch to select from [INITIAL] and [USER]  
Each time you press the switch, change [INITIAL] and [USER]
- 3 After selecting, Press [ENTER] switch

## 3.2.6 LAN Parameter

---

Set LAN interface parameter

```
*  L A N   P A R A M E T E R S  *  
I P      = 1 9 2 . 1 6 8 . 1 0 0 . 1  
M A S K  = 2 5 5 . 2 5 5 . 0 . 0  
P O R T  = 5 0 0 0 0
```

The procedure for setting is as follows;

- 1 Press [CHANGE] switch.  
The cursor on the [IP] line will blink and able to enter the data.
- 2 Press [ROTATION] switch and change the data each digit. Each time pressing, the figure will be changed as below; Press [SHIFT] switch to move the cursor to next digit.  
. → 0 → 1 → 2 → 3 → 4 → 5 → 6 → 7 → 8 → 9 . . . .
- 3 After setting, press [ENTER] switch to move to next line
- 4 After completing of entry, Press [ENTER] switch.



Memo \_\_\_\_\_  
Be sure to turn off once after change the Interface parameter.

## 3.2.7 RS-232C Parameter

---

Set Communication parameter in RS-232C

```
* RS - 2 3 2 C P A R A M E T E R S *  
  B A U D   R A T E = 3 8 4 0 0  
  D E L I M I T E R = C R L F
```

The procedure for setting is as follows;

- 1 Press [CHANGE] switch.  
The cursor on [BAUD RATE] data blinks and be able to change data.
- 2 Press [ROTATION] switch to select setting.  
Each time pressing [ROTATION] switch, options are changed as follows;  
BAUD RATE : 38400→9600→19200→38400...  
DELIMITER : CRLF→CR→CRLF...
- 3 Press [SHIFT] switch to move next line.
- 4 After selecting, Press [ENTER] switch.

 Memo

Be sure to turn off once after changing interface parameter.

## 3.2.8 Auto calibration

---

Set on or off auto calibration of photo detector.

```
* A U T O   C A L I B R A T I O N *  
  
      O N
```

The procedure for setting is as follows;

- 1 Press [CHANGE] switch
- 2 Press [ROTATION] switch to select On or Off.  
Each time pressing the switch, [ON/OFF] on the screen is changed
- 3 After setting , Press [ENTER] switch.

 Memo

Auto calibration ON: Calibration is conducted automatically in the following occasions;  
After warm-up, Before measurement, After 1000 times measurement in local mode.

Auto calibration OFF: It may lead to low accuracy of measured data, and thus it is recommended that Auto calibration is set to ON.

## 3.2.9 Buzzer

---

Set buzzer On or Off

```
*   BUZZER ON/OFF   *  
  
   O N
```

The procedure for operation as follow;

- 1 Press [CHANGE] switch
- 2 Press [ROTATION] switch to select [ON] or [OFF].  
Each time pressing the switch, ON and OFF is changed.
- 3 After selection, press [ENTER] switch.

## 3.2.10 Warm-up

---

Conduct the warm-up to stabilize the sensitivity of photo detector

```
*   PMT AGING   *  
  
   SHIFT : START
```

Press [SHIFT] switch to start warm-up.

The warm-up runs for 60 minutes.

```
D u r i n g   A g i n g  
           6 0 m i n u t e s
```

### Memo

The RD-80SA starts the warm-up automatically after turn on power. When usage condition is changed, Please conduct warm-up manually. The warm-up can be cancel by pressing [RUN] switch.

# 4. Communication to PC

## 4.1 Communication command

The RD-80SA can be communicated with PC via RS-232C and LAN interface.  
User commands for creating program by the customer are listed below.

## 4.2 Command list

Communication commands are as follows;

Communication command	Function
RM	Enters to the remote mode
LM	Enters to the local mode. (Returns from the remote mode.)
CAL	Conducts calibration
WHO	Reads Model name
VER	Reads Software version
SRL	Reads serial number
ST	Starts measurement. After completing measurement, measured data are sent from the instrument.
STC	Starts continuous measurement. Each measured data is not sent from the instrument.
SPC	Stops continuous measurement
SMS	Reads the status of continuous measurement 0:Normal stop 1:Continuous measurement 3:Abnormal stop
SMD	Reads latest measured data in continuous measurement
MV_#	Sets On or Off of average measurement. 0 : SINGLE 1 : AVERAGE
AV_#	Sets measurement times for average measurement Valid value range : 2 - 20
MG_#	Selects measurement range mode 0 : AUTO FULL 1 : AUTO FIRST 2 : AUTO ADJUST 3 : RANGE ALL 4 : RANGE EACH
SR_#	Sets common measurement range in [RANGE ALL] Valid value range : 1 - 8
FO_#	Sets measurement range for OPEN filter in [RANGE EACH] Valid value range : 1 - 8

FX_#	Sets measurement range for X2 filter in [RANGE EACH] Valid value range : 1 - 8
FY_#	Sets measurement range for Y filter in [RANGE EACH] Valid value range : 1 - 8
FZ_#	Sets measurement range for Z filter in [RANGE EACH] Valid value range : 1 - 8
MF_#	Selects filter 0 : OPEN 1 : X2 filter 2 : Y filter 3 : Z filter 4 : X2,Y,Z filter
FS_#	Specifies the correction factor number to be enabled. Valid value range : 0 - 10 ※0:correction fact is disabled
FG	Reads current correction factor number.
WF_#_####_####_####	Enters correction factor data. Valid value range : Correction factor number : 1 -10 Correction factor : 0.01 - 100.0
RF_#	Reads correction factor data in specifying correction factor number Valid value range : 1 - 10
CF_#	Initializes specifying correction factor. When specify "0", All correction factor data are initialized. Valid value range : 0 - 10
BR_#	Sets communication speed in RS-232C 0 : 9600 1 : 19200 2 : 38400
DM_#	Sets delimiter in RS-232C 0 : CR+LF 1 : CR
LIS_###.###.###.###	Sets IP address in LAN Setting takes active after restart the instrument. Valid value range : 192.168.100.1 - 192.168.255.255
LIG	Reads LAN IP address.
LMS_###.###.###.###	Sets sub net mask in LAN Setting takes active after restart the instrument. Valid value range : 255.255.0.0 - 255.255.255.255
LMG	Reads sub net mask in LAN
LPS_#####	Sets LAN port number Setting takes active after restart the instrument. Valid value range : 49152 - 65535
LPG	Reads LAN port number
PMT	Sets sensitivity mode of photo detector 0 : INITIAL 1 : USER
ERR	Reads latest error number.

"\_" means Space. "#" means numerical values.

Delimiter CR : 0x0d、LF : 0x0a

## 4.3 Communication Protocol

---

Communication protocol of RS-232C and LAN are as follows;

When you select delimiter to [CR], omit [LF].

The instrument returns "OK" for completing communication successfully. When the instrument can not read the command, the instrument returns "NG". When the instrument receive the command successfully but can not process the command, the instrument returns "NG".

 <b>Notice</b>	<p>In LAN communication, All command from the command response to the final command are sent together in series. So enough buffer are required.</p> <p>&lt;Example&gt;When you send "WHO" command, following 18[byte] data is stored in buffer.</p> <p style="text-align: center;">"OK"+CR+LF+"RD-80SA"+CR+LF+"END"+CR+LF</p>
----------------------------------------------------------------------------------------------------	-------------------------------------------------------------------------------------------------------------------------------------------------------------------------------------------------------------------------------------------------------------------------------------------------------------------------------

"\_" means space, "#" means numerical values.

### 4.3.1 RM Command

---

This command instructs the instrument to enter remote mode

When the instrument receive the RM command during remote mode, the instrument neglect the RM command and do not conduct initialize.

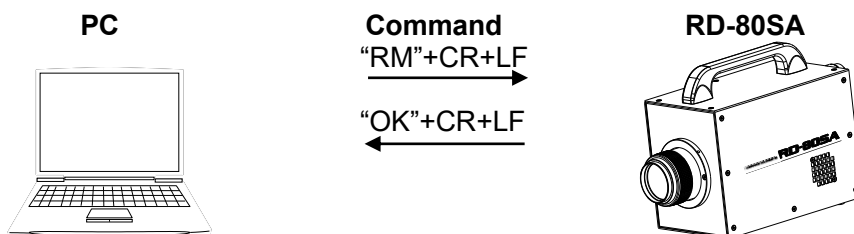

### 4.3.2 LM Command

---

This command instructs the instrument to enter local mode

When the instrument receive the LM command during local mode, the instrument neglect the LM command and do not conduct initialize.

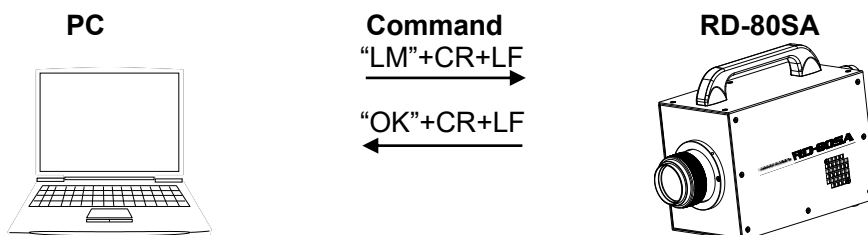

### 4.3.3 CAL Command

---

This command instructs the instrument to conduct calibration of photo detector

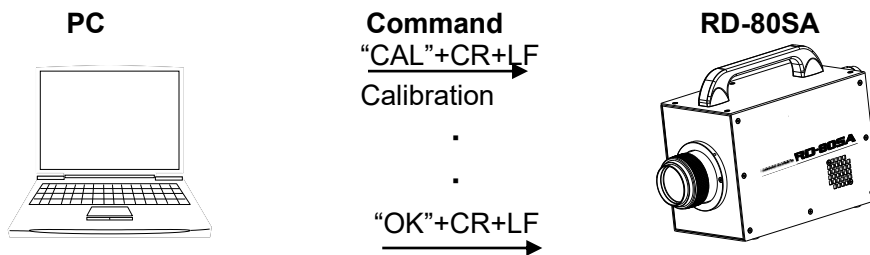

### 4.3.4 WHO Command

---

This command instructs the instrument to send the name of instrument

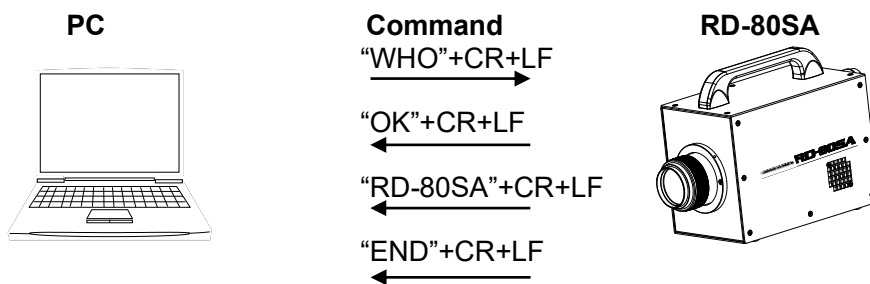

### 4.3.5 VER Command

---

This command instructs the instrument to send the software version number

Valid value range : 1.00-99.99

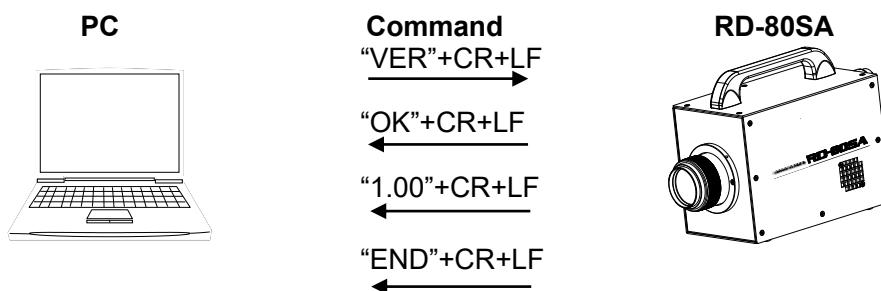

### 4.3.6 SRL Command

This command instructs the instrument to send serial number of the instrument  
 Valid value range : 00000000 – 99999999

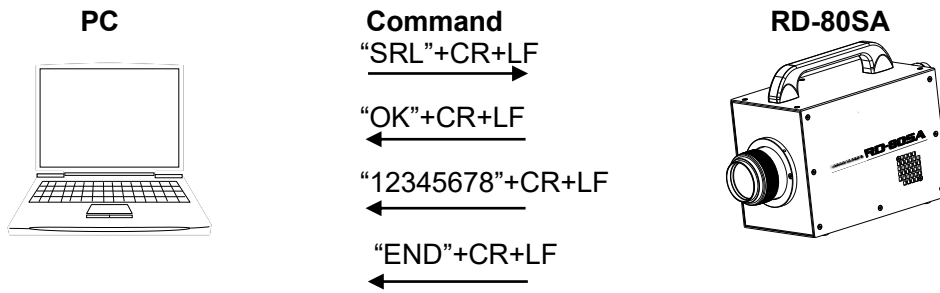

### 4.3.7 ST Command

The instrument instructs the instrument to start measurement immediately after receive this command according to specified each setting. When finish measurement, the instrument sends measured data according to 「4.4 Output format of Measurement data」

– Sending the command from PC to the instrument  
 PC or PLC send character string “ST” (0x53 0x54)+CR(0x0d)+LF(0x0a) via LAN or RS-232C

– Return from the instrument to the PC  
 The instrument returns “OK+CR+LF” immediately and starts measurement after the instrument receive ”ST” command.

The instrument sends measured data to PC according to 「4.4 Output format of Measurement data」 after finish measurement. If error occur in measurement, the instruments sends ”NG”+CR+LF to PC. You can check the details of err by sending ”ERR”+CR+LF to the instrument.

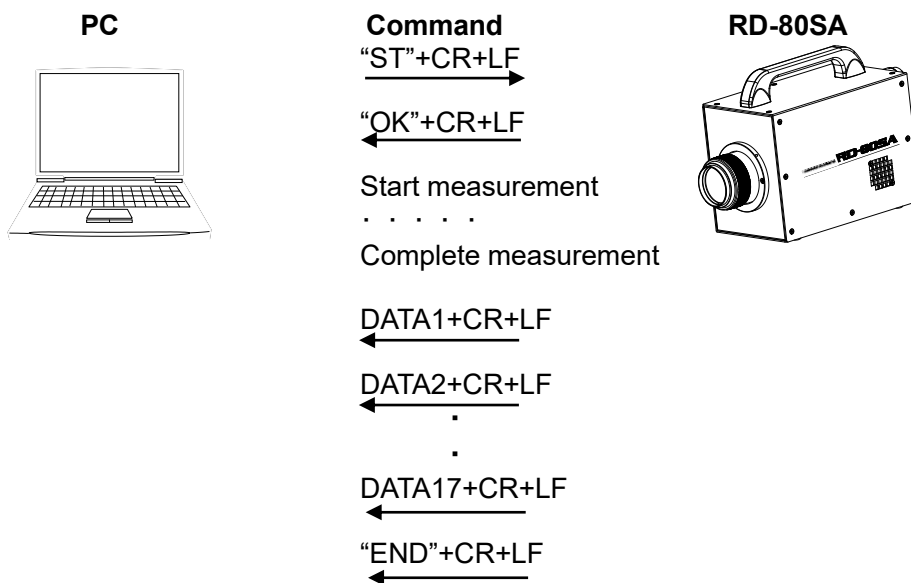

- When command can not received

“ST”+CR+LF  
→

←  
“NO”+CR+LF

- When measurement error

“ST”+CR+LF  
→

←  
“OK”+CR+LF

Start measurement

. . . . .

←  
“NG”+CR+LF

### 4.3.8 STC Command

The instrument starts continuous measurement according to specified each setting after receive this command. But the instrument does not send measured data after completing measurement. This command is used for monitoring analogue output.

After first measurement, the instrument will send the status of continuous measurement.

Return value 0 : Normal stop 1 : Continuous measurement 2 : Abnormal stop

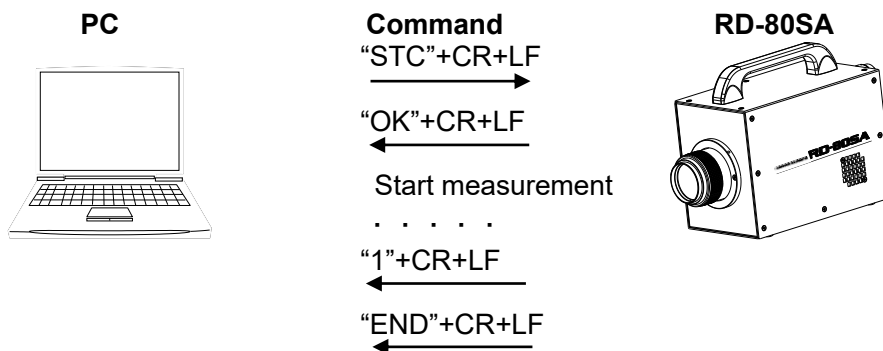

※The instrument does not send “END” command until completing first measurement.

### 4.3.9 SPC Command

This command stops the continuous measurement triggered by the STC command. The instrument will send the status of continuous measurement.

Return value 0 : Normal stop 1 : Continuous measurement 2 : Abnormal stop

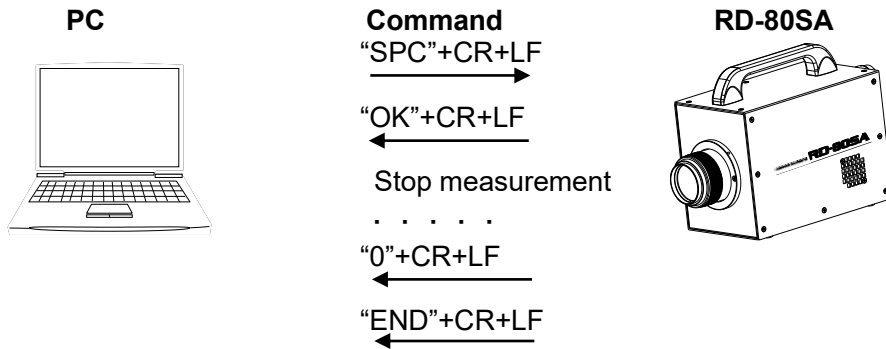

※The instrument do not send "END" command until completing first measurement.

### 4.3.10 SMS Command

Reads the latest status of continuous measurement. This command is available only when the instrument is in continuous measurement mode.

Return value 0 : Normal stop 1 : Continuous measurement 2 : Abnormal stop

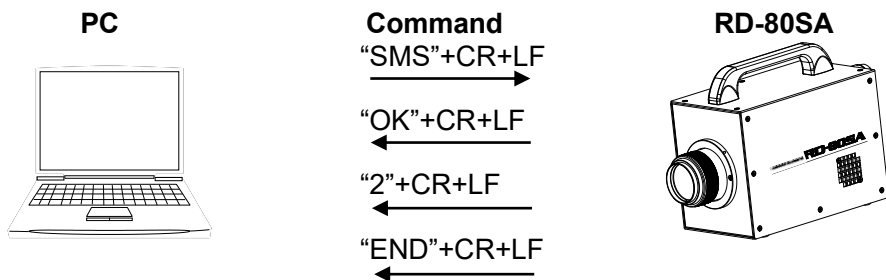

※When instrument receive this command, the instrument does not send "END" command until completing all measurement.

### 4.3.11 SMD Command

Reads latest measured data in continuous measurement

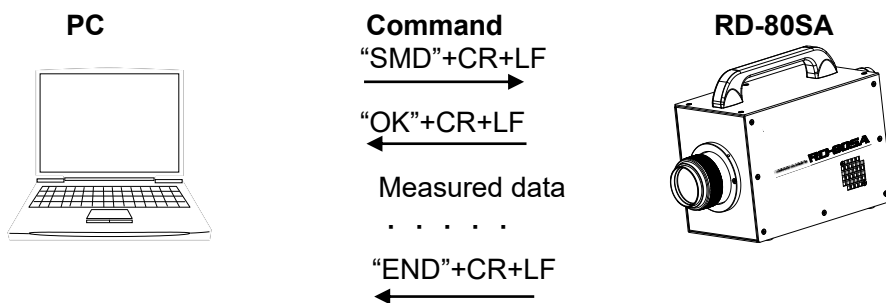

※The instrument does not send “END” command until completing all measurement.

### 4.3.12 MV\_# Command

---

This command sets on or off of average measurement

Valid value range 0 : SINGLE 1 : AVERAGE

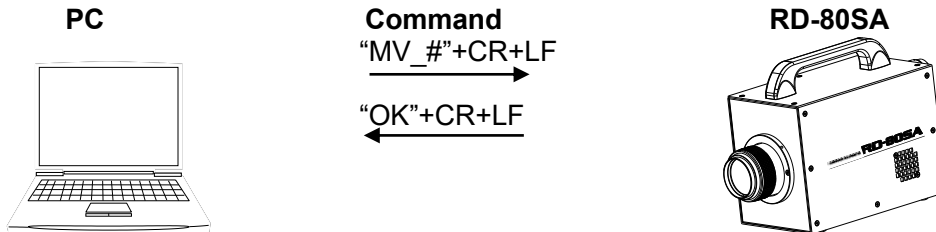

### 4.3.13 AV\_# Command

---

This command sets the number of measurement for average measurement

Valid value range : 2 - 20

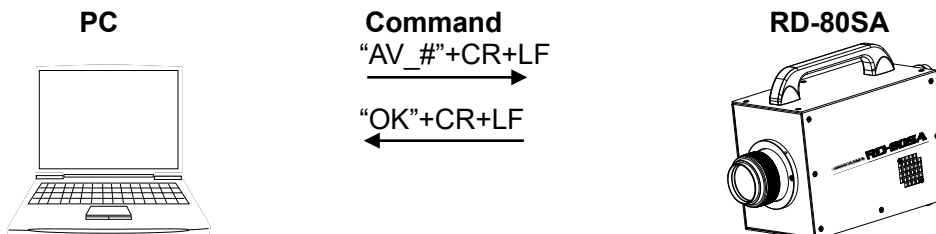

### 4.3.14 MG\_# Command

---

This command sets the measurement range mode

Valid value range 0 : AUTO FULL 1 : AUTO FIRST 2 : AUTO ADJUST  
3 : RANGE ALL 4 : RANGE EACH

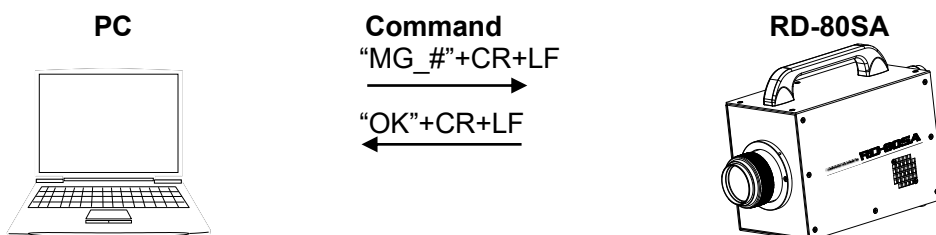

### 4.3.15 SR\_# Command

---

This command sets common measurement range in [RANGE ALL]

Valid value range : 1 - 8

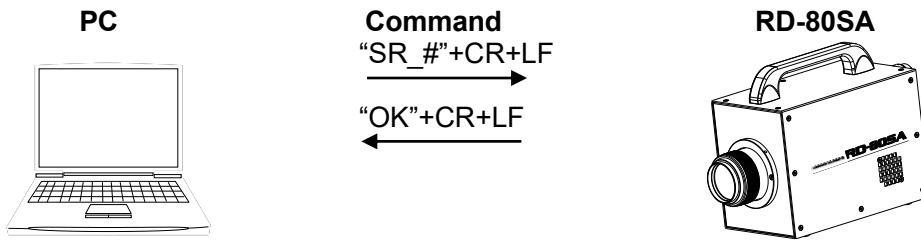

### 4.3.16 FO\_# / FX\_# / FY\_# / FZ\_# Command

---

This command sets the measurement range for each filter in [RANGE EACH]

FO : OPEN FX : X2 filter FY : Y filter FZ : Z filter

Valid value range : 1 – 8

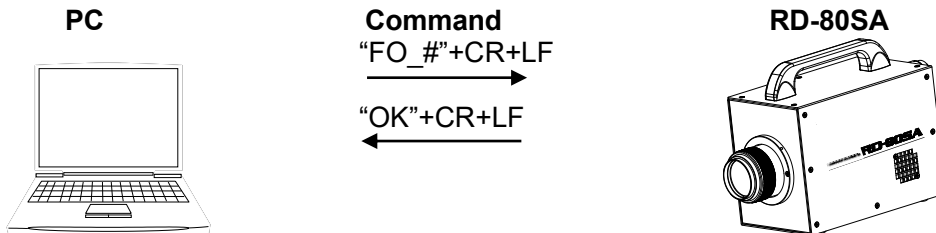

※Above is example of "FO" command

### 4.3.17 MF\_# Command

---

This command sets the type of filter

Valid value range 0 : OPEN 1 : X2 filter 2 : Y filter 3 : Z filter 4 : XYZ filter

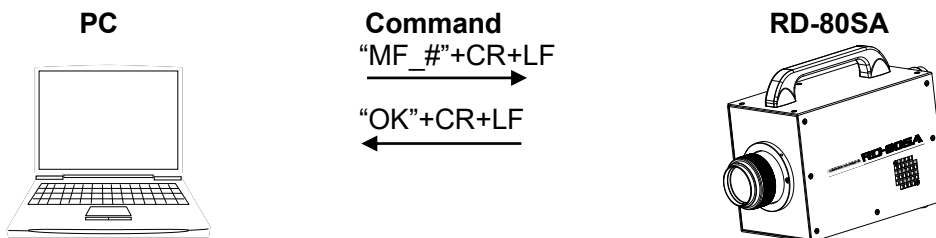

### 4.3.18 FS\_# Command

---

This command specifies the correction factor number to be enable

Valid value range : 0 – 10

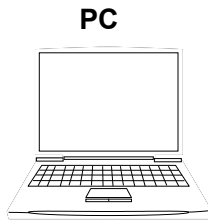

**Command**  
"FS\_#" + CR + LF  
→  
←  
"OK" + CR + LF



※0: correction factor is disabled

### 4.3.19 FG Command

---

This command instructs the instrument to send current correction factor number

Valid value range : 0 – 10 ※0: correction factor is disabled

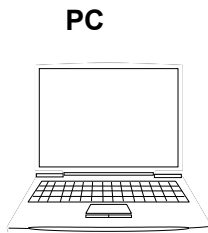

**Command**  
"FG" + CR + LF  
→  
←  
"OK" + CR + LF  
←  
"12346.6.78" + CR + LF  
←  
"END" + CR + LF  
←

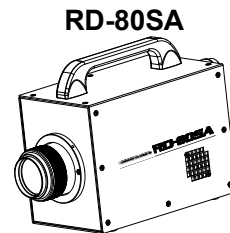

※0: correction factor is disabled.

### 4.3.20 WF\_#\_####\_####\_#### Command

---

This command writes correction factor data in the instrument

Send data : Correction factor number\_Correction factor for X filter\_Correction factor for Y filter\_Correction factor for Z filter

Valid value range : 0.01-100.0

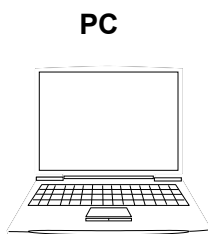

**Command**  
"WF\_#\_####\_####\_####" + CR + LF  
→  
←  
"OK" + CR + LF



### 4.3.21 RF\_# Command

---

This command instructs the instrument to send the correction factor data in specifying correction factor number.

Receive data : Correction factor for X filter → Correction factor for Y filter → Correction factor for Z filter

Valid value range : 0.01-100.0

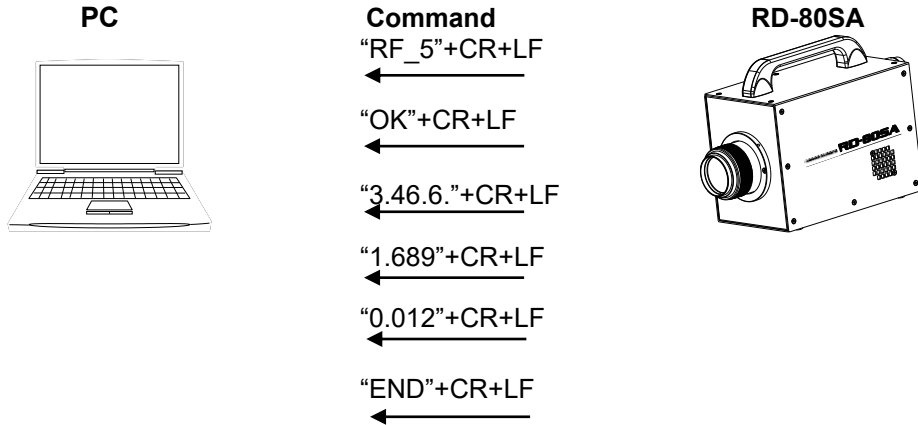

### 4.3.22 CF\_# Command

---

This command instructs the instrument to Initialize the correction factor data (Correction factor value to be 1.0) in specify correction factor number.

Valid value range : 0 - 10

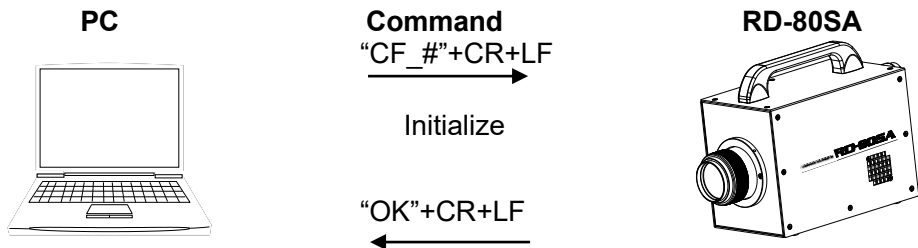

※0: When specify "0", all correction factor data are initialized.

### 4.3.23 BR\_# Command

---

This command sets the communication speed of RS-232C communication in the instrument

Valid value range 0 : 9600 1 : 19200 2 : 38400

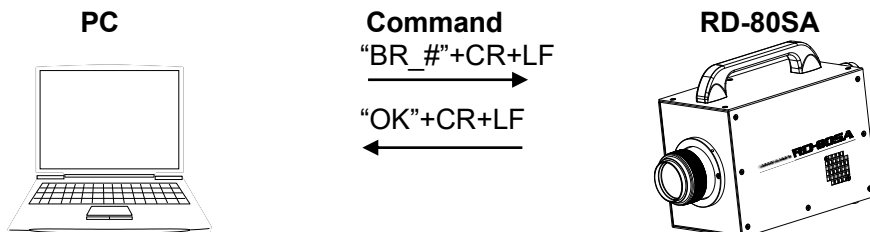

### 4.3.24 DM\_# Command

---

This command sets the delimiter of RS-232C communication in the instrument

Valid value range 0 : CR+LF 1 : CR

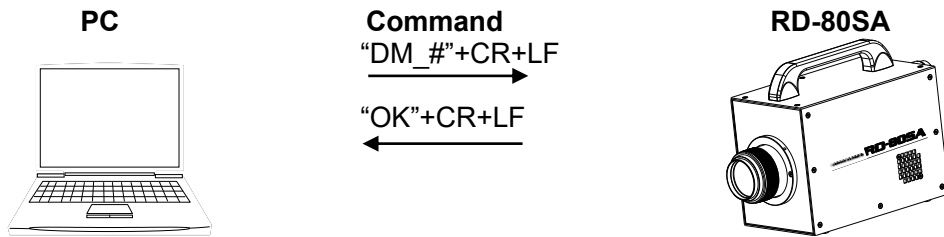

### 4.3.25 LIS\_###.###.###.### Command

---

This command sets the IP address in the instrument.

Valid value range : 192.168.0.0 - 192.168.255.255

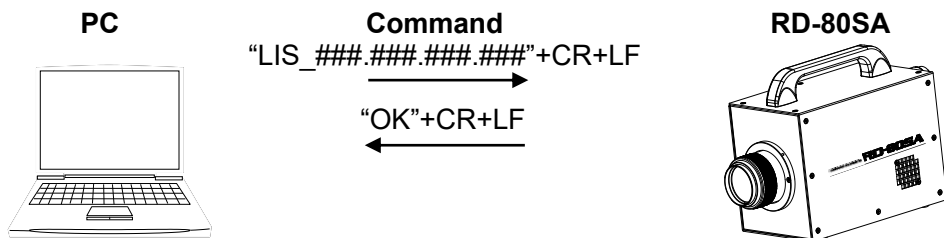

### 4.3.26 LIG Command

---

This command instructs the instrument to send current IP address

Valid value range : 192.168.0.0 - 192.168.255.255

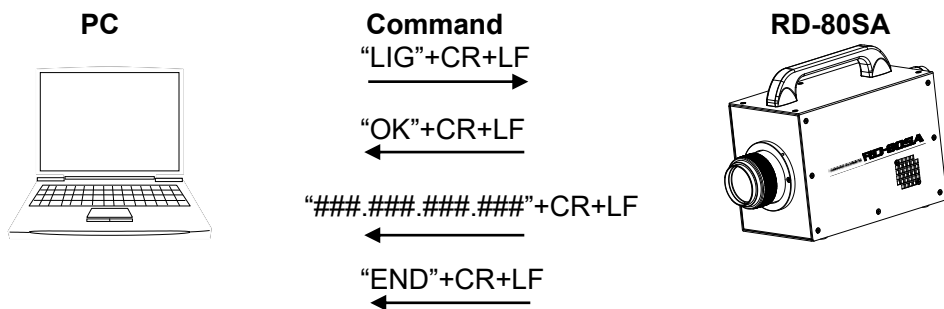

### 4.3.27 LMS\_###\_###\_###\_### Command

---

This command sets sub net mask

Valid value range : 255.255.0.0 - 255.255.255.255

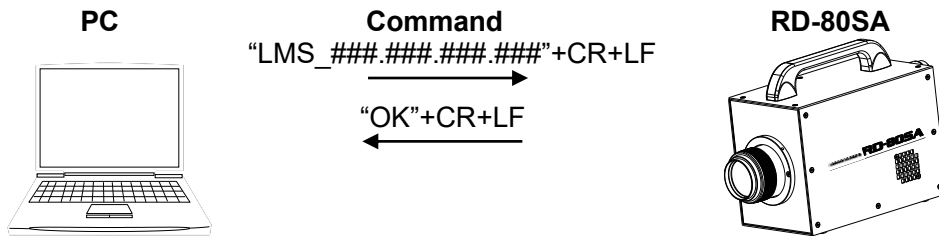

### 4.3.28 LMG Command

---

This command the instrument to send current sub net mask

Valid value range : 255.255.0.0 - 255.255.255.255

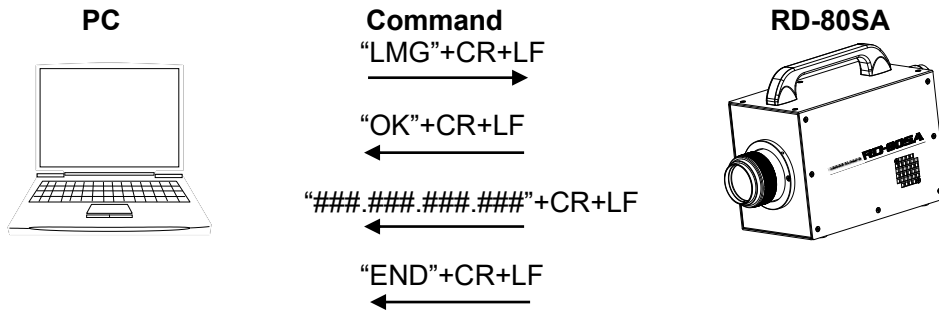

### 4.3.29 LPS\_##### Command

---

This command sets port number

Valid value range : 49126 - 65535

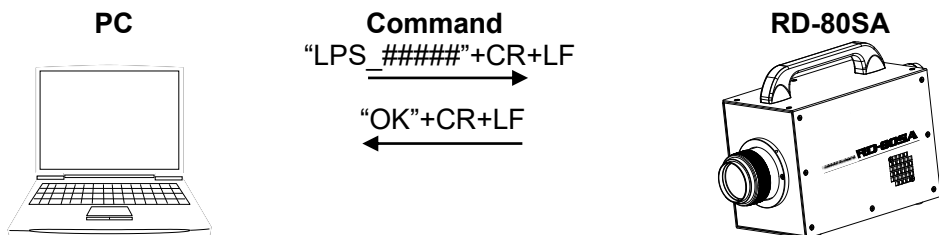

### 4.3.30 LPG Command

---

This command instructs the instrument to send current LAN port number

Valid value range : 49126 - 65535

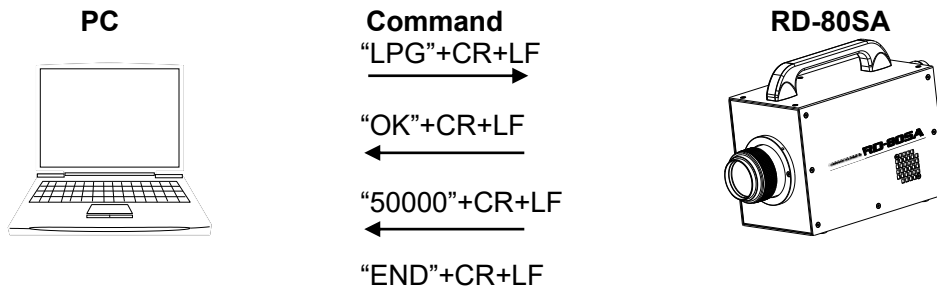

### 4.3.31 PMT Command

---

This command sets sensitivity mode of photo detector

Valid value range 0 : INITIAL 1 : USER

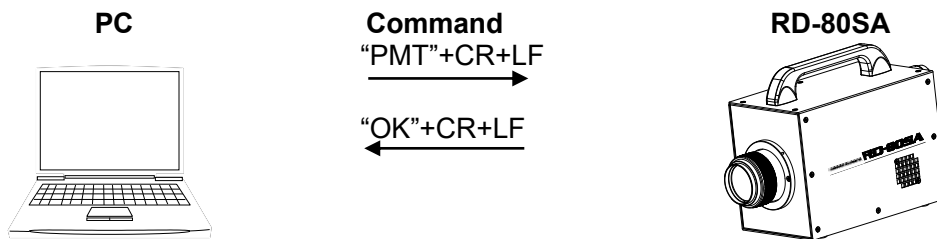

### 4.3.32 ERR Command

---

This command instructs the instrument to send latest error number

Error number : E0000 - E9999

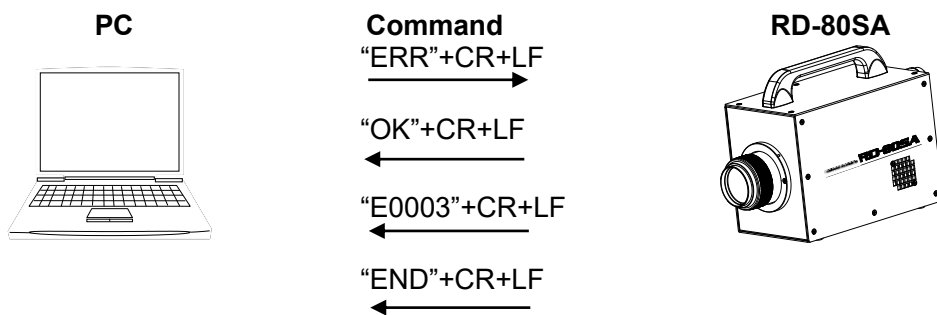

## 4.4 Output format

Output format of measured data are as follows

### ■ Data format

No.	Data	Unit	Data example	Details
1	Range for OPEN filter	—	1	Measurement range for OPEN filter
2	Range for X2 filter	—	2	Measurement range for X2 filter
3	Range for Y filter	—	3	Measurement range for Y filter
4	Range for Z filter	—	8	Measurement range for Z filter
5	Count	—	54321	A/D count value
6	Equivalent voltage	V	2.65	Equivalent voltage for A/D count value
7	Correction factor number	—	0	Current correction factor number
8	Luminance	cd/m <sup>2</sup>	3.4567E+001	Luminance
9	Tristimulus values X	—	4.5678E+001	Tristimulus values X
10	Tristimulus values Y	cd/m <sup>2</sup>	3.4567E+001	Tristimulus values Y
11	Tristimulus values Z	—	2.3456E+001	Tristimulus values Z
12	Chromaticity x	—	0.2345	Chromaticity x
13	Chromaticity y	—	0.3456	Chromaticity y
14	Chromaticity u'	—	0.1234	Chromaticity u'
15	Chromaticity v'	—	0.5678	Chromaticity v'
16	Color Temperature	K	2856	Color Temperature
17	Deviation	—	0.0456	Deviation
18	Data termination	—	"END"	Termination in output data

- ※1 The instrument send " \* \* \* \* " for out of valid range.
- ※2 Output data for Items that is not in active use Items are " \* \* \* \* "
- ※3 The data of Count and Equivalent voltage are sent only when set single filter.

## 4.5 Error Code List

Error cord obtained via [ERR] command and their details are as below.

Code	Details	Countermeasure	Message on display
E0000	Normal		
E0001 E0015 E0016 E0017 E0018	System Error	Please contact your dealer or TechnoOptis Advise us of the error code, the circumstance when the problem happen in details. If momentary interruption of power, let us know it also.	system error range system error filter system error sensor system error motor system error
E0002 E0003	Error in internal memory	Internal memory error happen Restart the instrument. If the instrument does not recover from the error, Please contact your dealer or TechnoOptis. Advise us of the error code, the circumstance when the problem happen in details. If momentary interruption of power, let us know it also.	memory init error memory access error
E0004 E0005	Failure of Photo detector calibration	Please contact your dealer or TechnoOptis. Advise us of the error code, the circumstance when the problem happen, and following points; – Error happen again after press [CALIB] switch ? – Error happen during measurement ? – Measurement data is correct ?	calibration error calculation error
E0006	Receive parameter is abnormal	Check following points - Parameter in sending is specified within valid value range? - The number of parameter is correct?	parameter error

E0007 E0009	Failure of RS-232C initialization Failure of LAN initialization	Inner device might be damaged Restart the instrument. If the instrument does not recover from the error, Please contact your dealer or TechnoOptis. Advice us of the error code, the circumstance when the problem happen in details. If momentary interruption of power, let us know it also.	RS-232C init error LAN init error
E0008 E0010	Error happen in RS-232C communication Error happen LAN communication	Check following points; – Communication setting in PC and the instrument – Cable and connection in PC and the instrument	RS-232C trans error LAN trans error
E0011 E0012	Under range error happen Over range error happen	Check to see if the luminance of the object is within the measurable range.	under range error over range error
E0014	Entry data is beyond valid value range.	Enter the data within valid value range	value out of range
E0019 E0020 E0021 E0022 E0023 E0024 . . . E0031 E0032 E0033 E0034 E0035 E0036	Error happen in motor or sensor	Error or sensory might be damaged Restart the instrument. If the instrument does not recover from the error, Please contact your dealer or TechnoOptis. Advice us of the error code, the circumstance when the problem happen in details. If momentary interruption of power, let us know it also.	motor* init error motor* origin error motor* move error motor* sensor error motor* signal error motor* pos error

# Appendix

## Specification

**Measurement angle** : 2° only

### Optics

Viewfinder field of view : 5°

Objective lens : f = 80mm F2.5

**Photo detector** : Photomultiplier Tube

**Measurement distance** : 350mm ~ ∞ (from the tip of the metal fixture on the instrument of the objective lens)

### Measurement Diameter

(Unit: mmφ)

	Measurement distance(m)				
	0.35	0.5	1	5	10
Diameter	10	15.4	32.8	169	341

※ The measurement distance is the distance from the tip of the metal fixture on the instrument of the objective lens.

※ The diameter may change slightly according to the matching precision of the aperture mirror.

### Measurement Function

The measured data are represented in following unit.

x, y, L (x, y : Chromaticity, L : Luminance)

u', v', L (u', v' : Chromaticity, L : Luminance)

X, Y, Z (X, Y, Z : Tristimulus values)

Tc, duv, L (Tc : Color temperature, duv : Deviation)

### Measurement time

About 1 second (SINGLE measurement, Y filter only, Range 4, Do not Auto calibration )

### Analogue output speed

80μs or less

※The response speed in the table above is the time that it takes analog output from the instrument to reach 90% of the peak value, when measuring an LED driven by a square wave from a function generator.

### Unit for Luminance

Candela per square meter (cd/m<sup>2</sup>)

### Measurement range (for standard illuminant A)

About 0.1 cd/m<sup>2</sup> - 10000 cd/m<sup>2</sup>

RANGE	Measurement range (cd/m <sup>2</sup> )		
1	0.1	—	5
2	0.5	—	15
3	1.5	—	40
4	3.5	—	120
5	15	—	600
6	35	—	1600
7	220	—	2900
8	750	—	10000

※Output voltage of 1V at range 5 is adjusted to 200cd/m<sup>2</sup> for standard illuminant A.

※3.4V is upper limit of output voltage in each range.

※Above value is design reference value. Measurable range may vary from the performance of density filter.

### Linearity (for Standard illuminant A, Auto range)

Luminance : ±3% 2 cd/m<sup>2</sup> or below  
±2% 2 cd/m<sup>2</sup> or above

Accuracy is guaranteed for measurable range only

### Chromaticity (for standard illuminant A, Auto Range)

—Chromaticity 1

Δx, Δy : ±0.0040 2 cd/m<sup>2</sup> or below  
±0.0025 2 cd/m<sup>2</sup> or above

Accuracy is guaranteed for measurable range only

—Chromaticity 2

Δx, Δy : ±0.01

For a combination of the standard light and following color glass  
O-55、Y-48、A-73B、IRA-05、T-44

Δx, Δy : ±0.03

For a combination of the standard light and following color glass  
R-61、B-46、V-44、G-54

**Repeatability (Standard Illuminance A, Auto range, SINGLE mode, 2 $\sigma$ )**

Luminance : Within 2% 2 cd/m<sup>2</sup> or below  
With in 1% 2 cd/m<sup>2</sup> or above

The specification is guaranteed for measurable range only

Chromaticity : xy within 0.003 0.5 cd/m<sup>2</sup> - 2 cd/m<sup>2</sup>  
xy within 0.002 2 cd/m<sup>2</sup> or above

The specification is guaranteed for measurable range only

**Temperature characteristics**

±3% (0°C - 35°C based on the measured data at 20°C)

**Humidity characteristics**

±3% (60%RH or less, based on the measured data at 50%RH)

**Measurement range**

8 steps (Auto range or Manual range)

**Adjustment volume**

– Over range, Under range adjustment function

Adjusts the over / under range level

Over range : About 2 - 3.4V (Default : 3.3V)

Under range : About 0 - 1.2V (Default : 0.03V)

– Sensitivity of photo detector adjustment function

Adjusts the sensitivity of photo detector

Valid range : About 0 - 1.0V

Recommend : About 0.3 - 0.5V

(When raise the sensitivity, noise increase. Use recommended range)

Default applied voltage is as follow;

1.00V±0.005V at 200 cd/m<sup>2</sup> for standard illuminant A

– Analogue output offset adjustment function

Adjusts analogue output offset

Valid range : About ±1V

Default : 0.05V (in measurement of Dark)

**Calibration standard**

TechnoOptis Calibration standard (Standard illuminant A, 23°C±3°C)

**Display**

Dot matrix LCD 20 characters × 4 lines with back light

**Interface**

LAN / RS-232C

**Analogue output voltage range**

About 0 - 3.4V

**Power supply**

Dedicated AC Adapter (standard accessories)

AC100V - 240V (50/60Hz)

**Power consumption**

About 34W

**Operating condition**

Temperature : 0°C - 35°C

Humidity : 60% RH or less (no condensation)

**Storing condition**

Temperature : -10°C~50°C

Humidity : 80% RH or less (no condensation)

**External dimension**

About 319 mm(L)×130 mm(W)×201 mm(H)

**Weight**

About 4.3kg (main body only)

Republic of Korea	KC:Class A	<p>해당 무선설비는 전파혼신 가능성이 있으므로 인명안전과 관련된 서비스는 할 수 없습니다</p> <p>A급 기기 (업무용 방송통신기자재)</p> <p>이 기기는 업무용(A급) 전자파적합기기로서 판매자 또는 사용자는 이 점을 주의하시기 바라며, 가정외의 지역에서 사용하는 것을 목적으로 합니다</p>
-------------------	------------	-------------------------------------------------------------------------------------------------------------------------------------------------------------------------

# Block Diagram

## Block Diagram

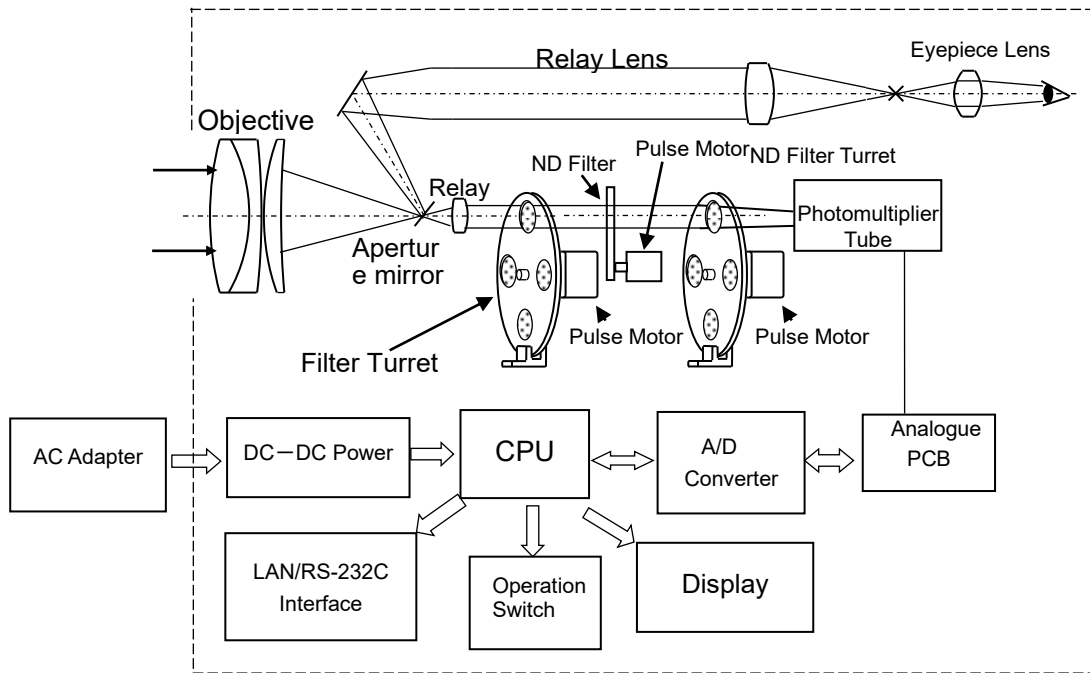

## Spectral Sensitivity Curve

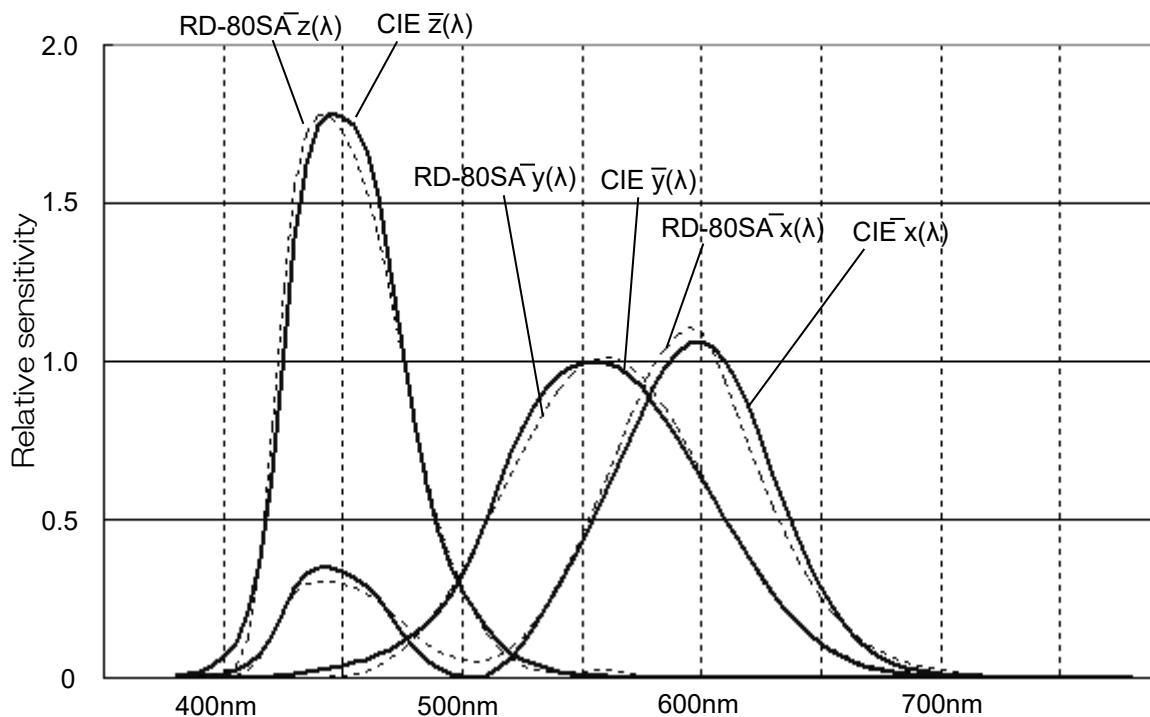

※ This data is one sample from our products. Data is different from each products.

# External Dimension



## Request

Use only specified screws when using the tripod screw and screw holes for jig attachment. Do not tighten the screws any more than necessary. Doing so might cause internal breakage.

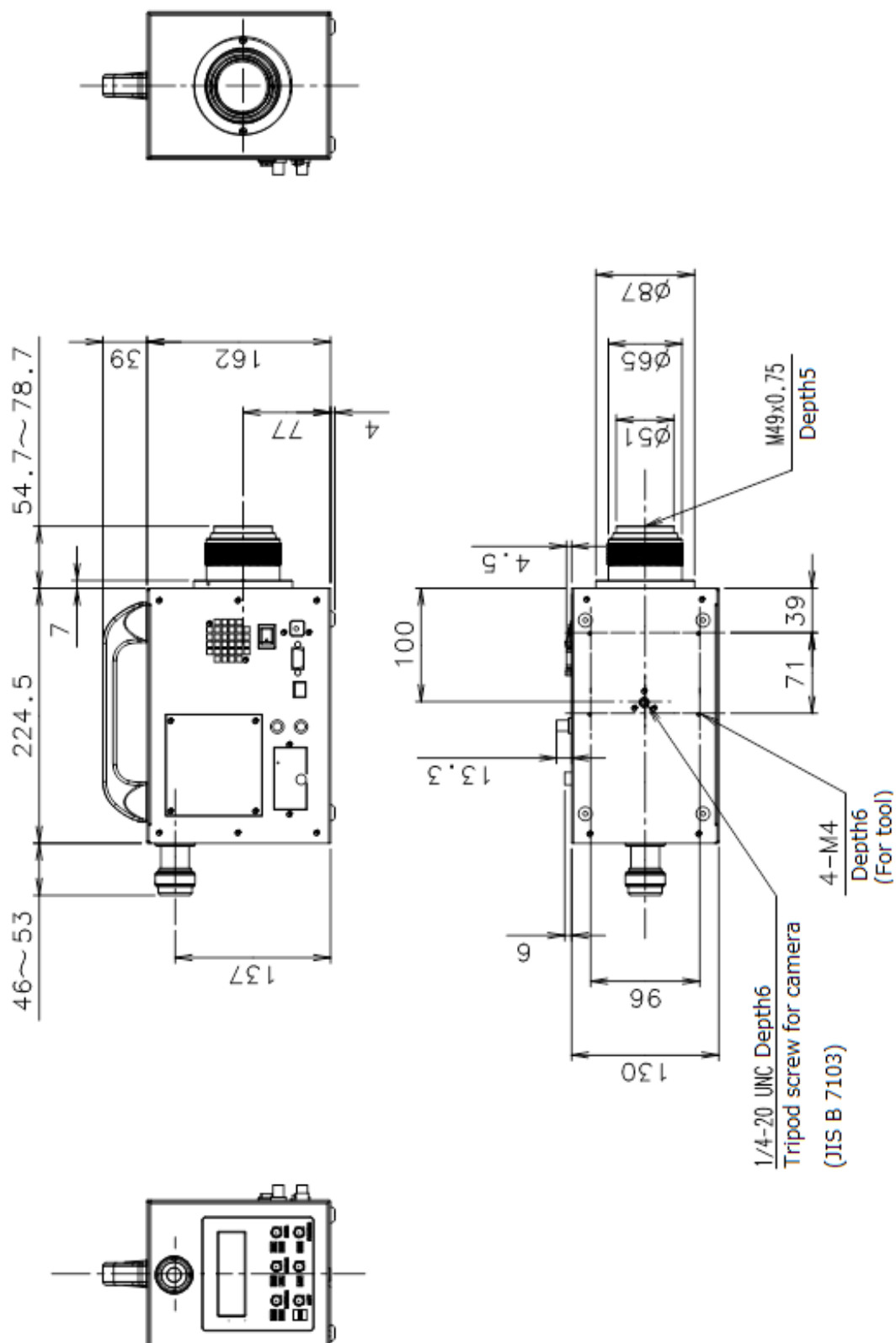

# Internal Calculation Processing

---

The instrument calculate data according to following formula

## Chromaticity coordinate

xy chromaticity coordinates of a XYZ color coordinate system

$$x = \frac{X}{X + Y + Z} \quad y = \frac{Y}{X + Y + Z}$$

u'v' chromaticity coordinates of a UCS color coordinate system

$$u' = \frac{4X}{X + 15Y + 3Z} \quad v' = \frac{9Y}{X + 15Y + 3Z}$$

## Color Temperature, Deviation

Color temperature and deviation are calculated according to JIS Z 8725 "Method for determining distribution temperature and color temperature or correlated color temperature of light source."

Color temperature display range  $1563\text{K} \leq T_c \leq 100000\text{K}$

Deviation display range  $-0.02 \leq d_{uv} \leq 0.02$

Deviation is the distance from the blackbody locus on the CIE 1960 UCS color diagram.

# Terminology

---

## **Correction Factor:**

This refers to three factors, KX, KY and KZ, for correcting Tristimulus values.

## **White Board:**

This is a white board with good diffusion, made of barium sulfate, etc.

## **Local Mode:**

This is the normal measurement status.

In this mode, the instrument is operated by the panel switches, and cannot be controlled by an external PC.

## **Remote Mode:**

In this mode, the instrument is controlled by an external PC via the interface. It can also be controlled by its panel switches.

## **Function Mode:**

This mode is for displaying and changing the data stored in the instrument's memory.

### Warranty Period

1 year from the date of shipment

### Repairs during the Warranty Period

The failure occurring on the instrument when the instrument has been operated according to the instructions in the Instruction Manual and the failure caused by design or manufacture will be repaired free of charge.

### Repairs after the Warranty Period

Repairs after the warranty period are carried out if possible and must be paid in full by the user.

### Maintenance Period

The repair parts (\*1) are retained by us for eight years (\*2) after purchase.

The repairable period is this period that parts are kept in stock.

Even after the storage period has elapsed, there are cases in which repair may be possible, so contact your dealer or TechnoOptis.

(\*1) Maintenance and repair parts are parts that are required for maintaining the function of the product.

(\*2) We make utmost effort to keep maintenance and repair parts in stock for the complete storage period. However, due to unexpected occurrences, the storage period may be shortened.

### Disposal

Dispose of the instrument in accordance with local disposal and recycling laws and regulations.

---

### When you ask for service, advise us of the following data:

- Manufacturing serial number      Located on the ratings plate on the bottom of the device
- Period of use      The date of purchase of the instrument, and date of last calibration
- Operating conditions      Type of light source measured, instrument settings, measurement values, measurement state, etc.
- Problem      Description of the trouble in as much detail as possible

Contact information      Make inquiries to the address indicated on the base of the rear inside cover of the Instruction Manual.

# Luminance Colorimeter

---

# ***RD-80SA***

---

## Contact information:

### **TechnoOptis Co., Ltd.**

4F, Imas Itabashi BASE, 2-4-1, Sakashita, Itabashi-ku,  
Tokyo 174-0043 JAPAN

#### ◆ **Inquiries regarding the product**

Tel +81-3(3558)2666      Fax +81-3(3558)4661

#### ◆ **Inquiries regarding repairs and maintenance**

Tel +81-3(3558)2710      Fax +81-3(3558)3011

---

Luminance Colorimeter RD-80SA Instruction Manual

Date of issue of 1st edition Aug., 2011

8th edition Jun., 2026

Published by: TechnoOptis Co., Ltd.

---

©2011 TechnoOptis Co., Ltd.

ALL RIGHTS RESERVED

Copying and reproduction without permission are prohibited.