

TechnoOptis

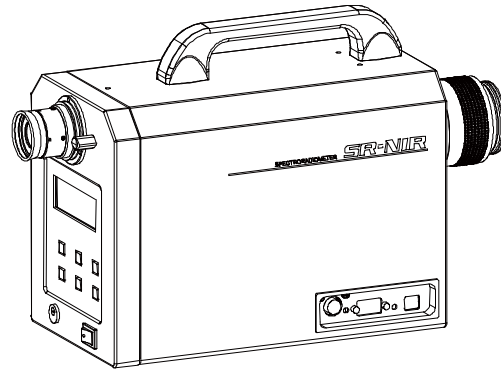

INSTRUCTION MANUAL
SPECTRORADIOMETER

SR-NIR

Rev.11

Introduction

Thank you for your purchasing our product, Spectroradiometer SR-NIR.

The spectroradiometer SR-NIR can measure the spectral distribution of PDP, CRT, LCD, the back light of LCD, and the reflected light of luminous bodies such as LED, coated surfaces and printed substances. Moreover, by using SR-NIR with the spectroradiometer SR series, it can measure the spectral distribution of the visible light and near infrared light (380nm to 1030nm) with high precision.



This manual describes the outline, basic operation, and the specifications of the spectroradiometer SR-NIR.

Please keep this Manual near you for operating this device.

Display for Safe Use







The instruction panels on the device and this Instruction Manual describe important things to prevent the dangers to the operator or others and damages to your properties from occurring, and to secure your operating this device.

Be sure to understand the following indications and symbols, read the precautions and the contents, and observe the written instructions fully.







Indication marks	Meaning of marks
 Danger	This "Danger" mark indicates that ignoring this indication and mishandling the system may cause dangerous accidents that may cause death or severe injury to you or others.
 Warning	This "Warning" mark indicates that ignoring this indication and mishandling the device may cause death or severe injury to you or others.
 Caution	This "Caution" mark indicates that ignoring this indication and mishandling the device may cause injury to you or others ^{*1} or cause property damage ^{*2} .

*1 Injury stated here indicates the injury, burn, or electric shock that does not require you hospitalization or visiting the hospital for a long time.





*2 Property damage stated here indicates the damages widely spread to the building, properties, domestic animals, or pets.

Symbols	Meaning of symbols
	This mark indicates the prohibited matter. Detailed content of the prohibited matter is stated or indicated by the symbol in or near the mark. (Example  : Do not touch the operating units.)
	This icon indicates Mandatory Action. Specific content is expressed with words or an icon located close to the icon. (Example  : Perform grounding.)
	This mark indicates the caution (including the warning). Detailed content of the prohibited matter is stated or indicated by the symbol in or near the mark. (Example  : Be careful for electric shock.)

 **Warning**

Symbols	Precautions
 Prohibited	Never use the system in flammable or ignitable vapor-floated (gasoline, etc.) place. This may cause the fire.
 Prohibited	Never disassemble or modify the device. This may cause the fire and electric shock.
 Mandatory	Be sure to use the AC adapter which is the standard or optional accessory. The defective AC adapter may cause fire or electric shock.
 Prohibited	Never disassemble AC adapter This may cause the fire and electric shock.
 Mandatory	Be sure to remove the dust or moisture around the plug and outlet of AC adapter. This may cause the fire.
 Mandatory	If abnormal sound, unusual smell, or smoke are found in the device, turn off the power quickly and pull out the AC adapter cable from the outlet. Continuing to use the device may cause the fire.

 **Caution**

Symbols	Precautions
 Prohibited	Never watch the Sun or the filament of an electric bulb directly. This may injure your eyes.
 Prohibited	Never put the device (or other objects) on the unstable places like wobbly table or inclined surface. Dropping or falling of the device (or other objects) may injure you.
 Prohibited	Never pull out or insert the plug by wet hand. This may cause electric shock.
 Mandatory	When using the tripod mounting screw hole and the jig mounting screw hole, use the specified screw. Do not tighten the screw excessively. The inside of the instrument may be broken.

Disclaimer

- We are not responsible for the damages caused by various problems such as, fire, earthquake, behaviors by other persons, other accidents, intentional or negligent or wrong use of the device by the operator, and the use of the device under abnormal conditions.
- We are not responsible for incidental damages arising from the use or unavailability of the device (loss of business income, business interruption, etc.).
- We are not responsible for the damages caused by the uses other than specified in the Instruction Manual.
- We are not responsible for the damages caused by the malfunction due to the combination with the connecting devices.

Precautions for Use

- Use the AC adapter, which is the standard or optional accessory. Any other AC adapter except the specified one may cause malfunction. For the power supply used for this instrument, the input voltage is AC100V to 240V and the frequency is 50Hz to 60Hz.
- For energy saving, when this instrument will not be used for an extended period of time, disconnect the power plug from the outlet.
- Keep this instrument away from water and liquid. It is not water-resistant.
- Never measure the light source exceeding the measurable range or the sunlight. Such behaviors may damage the photo detector and make it impossible to perform the stabilized measurement.
- When using this instrument, do not turn ON the power right after turning it OFF. Because the instrument inside is hot, the protective circuit works to indicate an error. In such a case, turn off the power and leave the instrument as it is for about 30 minutes under the usable condition (5 to 35°C). Then, turn on the power.

 “5.1 Error Display of Instrument”.

- Never use this instrument in the place which is dusty or humid or generates corrosive gas.
- Never use this instrument where the temperature tends to vary rapidly. Although a temperature compensating circuit is built in this instrument, it may not perform the stabilized measurement under the environment where the temperature tends to vary rapidly.
- Never use or store this instrument in a place which is subject to heavy shock like falling or tends to vibrate at any time. Using or storing in such a place may damage the instrument equipped with delicate optical components. To carry this instrument, please put it in the accessory carrying case to prevent it from direct vibration or shock.
- To store this instrument, be sure to put it in the exclusive carrying case and keep it under constant temperature and humidity. Never store the instrument under high temperature and high humidity condition (for example, in a car).
- To maintain the measurement precision, be sure to perform the calibration at least once a year. For the calibration, consult the local retailer from which you purchased the instrument or TechnoOptis.
- When the calibration is performed, the measurement data stored in this instrument are completely erased. Be sure to back up the necessary data in your personal computer, etc. before requesting the calibration.
- Never peel off the seal from the rear surface of this instrument. If it is peeled off, all of warranty will be invalid.

User Maintenance

Maintenance works other than instructed in this manual must not be carried out by anybody other than our servicing staff in order to keep the safety and performance. However, the following matters can be performed by the user for maintenance. Please read the section relevant to the maintenance method in this Manual.

Cleaning the instrument cover and lens

For the dirt of the instrument case and lens, please remove it with a soft cloth moistened with diluted neutral detergent. Then, wipe the case or lens with a dry soft cloth.

Never use solvent such as thinner, benzene and acetone. Such solvent may discolor the instrument surface

Table of Contents

Introduction

Display for Safe Use

Conventions in This Manual





1.	Before Use	1
1.1	Checking the Instrument and Accessories	1
1.2	Names and Functions of Components	2
1.3	Preparations.....	7
1.3.1	Connecting AC Adapter.....	7
1.3.2	Connecting PC	8
1.3.3	Alignment of Measurement Target.....	9
1.3.4	How to Turn On/Off the Power	10
1.3.5	Opening/Closing the Viewfinder Shutter	12
1.4	Maintenance Recommendation Display	13
2.	Measurement Procedures.....	14
2.1	Single Measurement (Single)	14
2.2	Continuous Measurement (Auto Run).....	16
2.3	Difference Measurement	17
2.4	Display of Measurement Data	19
2.5	Measuring	20
2.5.1	Measuring Directional Light Sources	20
2.5.2	Measuring Very Small Surfaces	20
2.5.3	System Integration.....	21
2.5.4	Measuring a Frequency Light Source	21
3.	Settings	22
3.1	Function Mode	22
3.1.1	Setting Items.....	22
3.1.2	Entering/Returning from the Function Mode	23
3.1.3	Setting Numerical Value	26
3.2	Measurement Mode	28
3.2.1	FREQ (Frequency) Mode	30
3.2.2	MANU (Manual) Mode.....	31
3.3	Integral Time Delay Function.....	32
3.3.1	Setting Delay Time	33
3.4	Single or Auto Run.....	34
3.5	PC Connection Method.....	35
3.6	RS-232C Parameters	36

3.7	Data Communication Method	38
3.8	Terminal Code of Remote Command.....	39
3.9	Using Correction Factor.....	40
3.10	Display/Change of Correction Factor	41
3.11	Average Measurement	43
3.11.1	Average Times	44
3.12	Selecting "OVER-RANGE" Detection in "MANU" Mode.....	45
3.13	Beep Sound	46
3.14	Maintenance Recommendation Display.....	47
3.15	Setting Auto Panel Light	48
3.16	Batch Deletion of Measurement Data/DIF Standard Data	49
4.	Communication with PC.....	50
4.1	Communication Command	50
4.1.1	RM/LM Command	52
4.1.2	ST Command	52
4.1.3	STB Command.....	55
4.1.4	A0/A1/A2/A3 Command	56
4.1.5	KW [n] Command	56
4.1.6	KR [n] Command	57
4.1.7	DR [n] Command.....	58
4.1.8	KO1/KN1 Command.....	58
4.1.9	KOR1 Command	59
4.1.10	AVE Command.....	59
4.1.11	AVER Command	59
4.1.12	AVT Command	60
4.1.13	AVTR Command	60
4.1.14	FLD1/FLD2/FLD3/FLD4 Command	60
4.1.15	FLDR Command.....	61
4.1.16	NL Command	61
4.1.17	ND/NF Command.....	62
4.1.18	WHO/SRL/VER Command.....	62
4.2	Output Format.....	63
4.2.1	Output Format of Remote Measurement	63
4.2.2	Output Format for Reading Internal Stored Data	64
4.3	Installing USB Driver.....	65
5.	Error Display	67
5.1	Error Display of Instrument.....	67
5.2	Error Code in Communication	68
6.	Appendices	69

Specifications and Performance 69
Block Diagram 71
External Dimensional Diagram..... 72

Conventions in This Manual

Description in this Manual is in accordance with the following notation.

Notation	Description
[FUNCTION], [UP]	This indicates the menu titles displayed on the panel switch or the liquid crystal display (LCD) unit.
	This shows the reference section within the Manual.
	This shows the reference document.
 Remember	This explains what you should know or consider before starting the operation.
 Note	This explains the reference or convenient matters helpful for your operation.

1. Before Use

1.1 Checking the Instrument and Accessories

Please check the instrument and all of the accessories shown below are provided.

If any of them is not found, please contact the local retailer from which you purchased the instrument or TechnoOptis.

- Main body

1

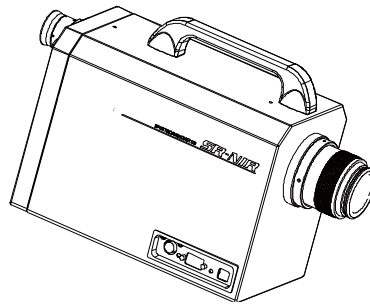

SR-NIR

- Objective lens cap
- SR-NIR Quick manual
- Colorimetry program CS-900A /Instruction manual (CD-ROM)
- AC adapter
- USB cable
- Inspection report
- Carrying case

1

1

1

1

1

1

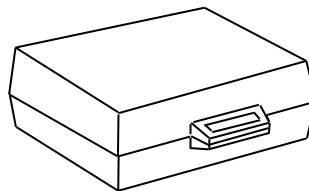

1

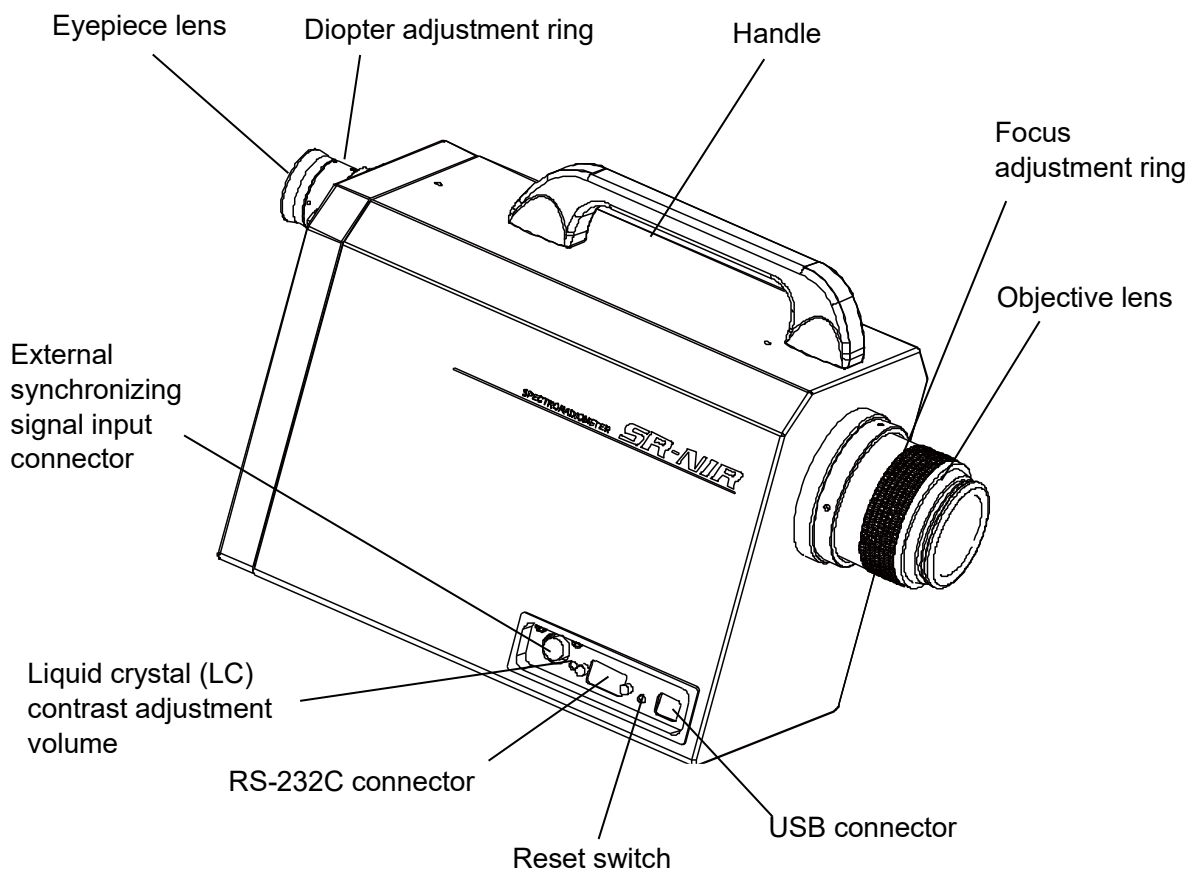

1.2 Names and Functions of Components

■ Instrument body



Diopter adjustment ring	Used to bring the viewfinder's reticle mark into focus.
Focus adjustment ring	Used to bring the measurement target into focus.
USB connector	Used to connect a personal computer (PC) or others when carrying out remote mode measurement. PC connection:  "1.3.2 Connecting PC".
RS-232C connector	Used to connect a personal computer (PC) or others when carrying out remote mode measurement. PC connection:  "1.3.2 Connecting PC".
External synchronizing signal input connector	Input the synchronizing signal through this connector when measuring a flashing light source such as CRT.
Reset switch	This is the reset switch for this instrument's software.
Liquid crystal (LC) contrast adjustment volume	Use this volume to adjust the contrast of the LC display unit. Use this when the characters on the LC display unit are not seen clearly.

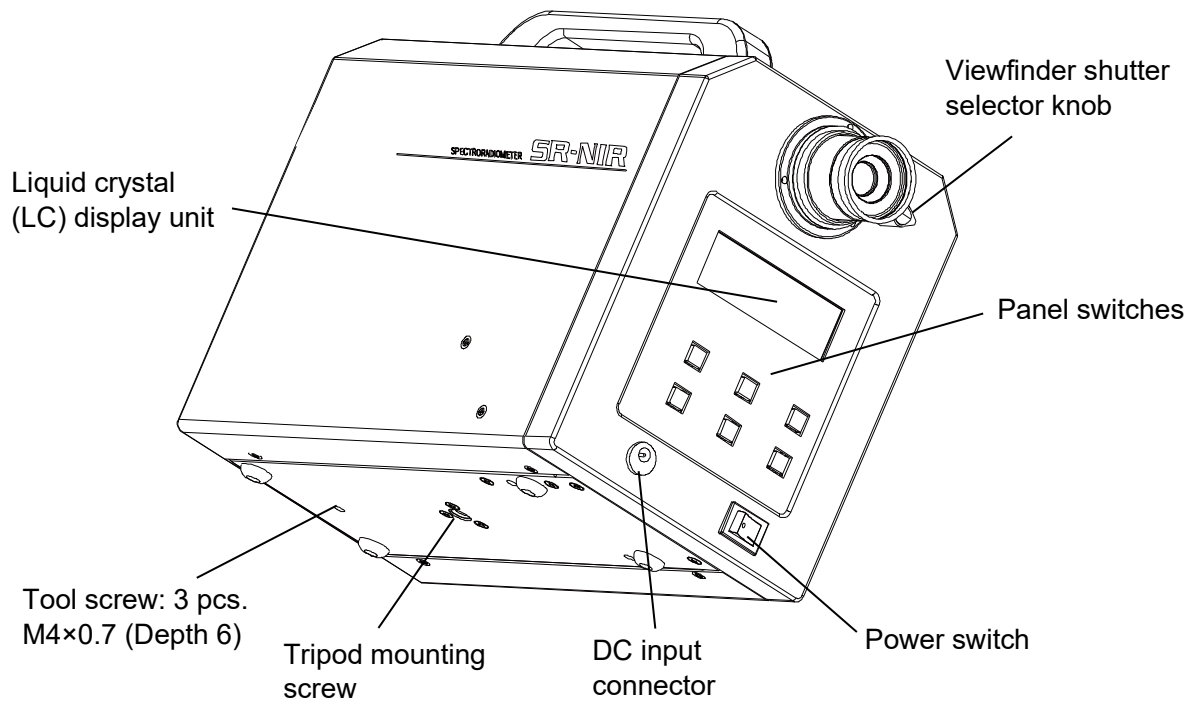

- | | |
|----------------------------------|---|
| Power switch | This is the power switch of this instrument. |
| DC input connector | Insert the output plug of the AC adapter, which is the accessory of this instrument, into this connector. |
| Viewfinder shutter selector knob | Set this knob at the “CLOSE” position to block the light entering through the viewfinder. When the measurement target is extremely dark or when there is a luminous body on the viewfinder side, set the viewfinder shutter to “CLOSE” in order to prevent the stray light from the viewfinder. |
| Liquid crystal (LC) display unit | This LC display unit is equipped with illumination and indicates a variety of information such as the measured values, measurement conditions or others. |
| Panel switches | The switches are used to start/stop measurement and perform other operations and to perform a variety of settings with the function mode. |
| Tripod mounting screw | The screw is used to mount the instrument on a tripod. The 1/4-UNC camera mounting screw is adopted. |
| Tool screw | The screw is used to mount the instrument on systems or others. The size is M4×0.7 (diameter: 4mm, pitch: 0.7mm). |

☞ “External Dimensional Diagram” of “6.Appendices

 Remember	<p>When using the tripod mounting screw hole and the jig mounting screw hole, use the specified screw. Do not tighten the screw excessively. The inside of the instrument may be broken.</p>
--	--

■ Names and functions of panel switches

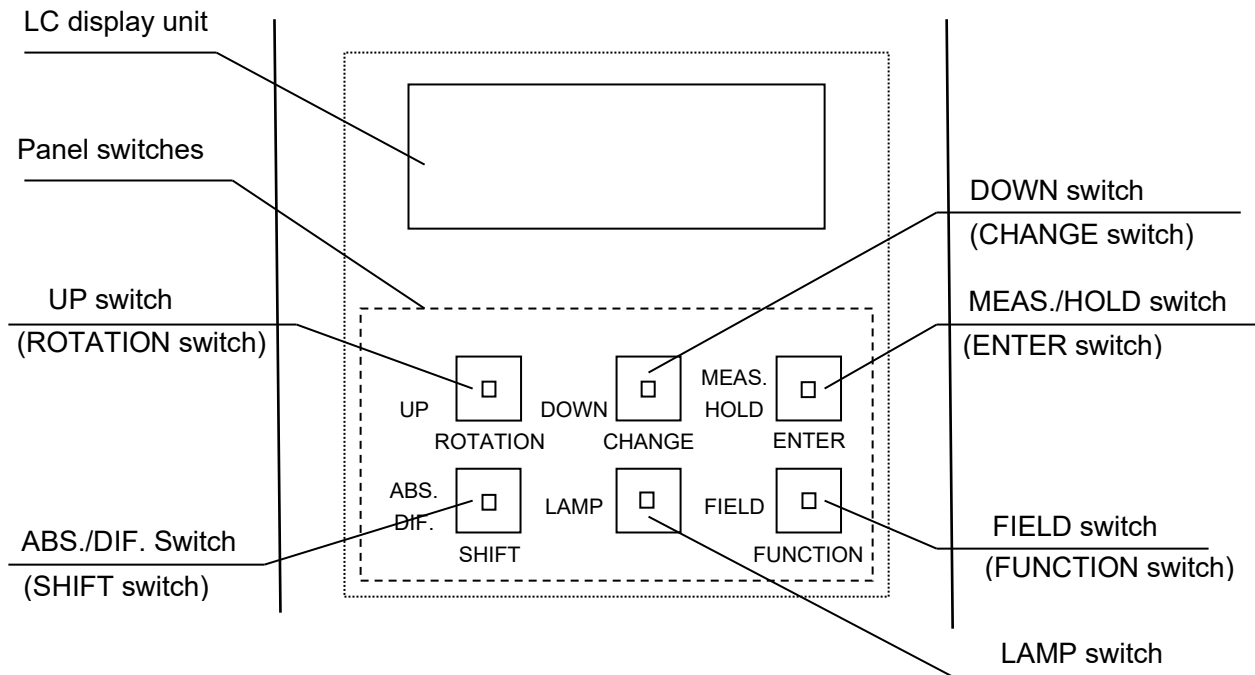

Switches

The panel switches have the following two types of functions.

- Functions used for measurement (Functions indicated beside the switches)
- Functions used for function mode (Functions indicated under the switches)

Changing to function mode: “3.1.2 Entering/Returning from the Function Mode”.

The functions of the switches are described below.

MEAS./HOLD switch	Used to start measurement or to stop continuous measurement (Auto Run). “2.2 Continuous Measurement (Auto Run)”.
FIELD switch	This switch changes the measuring angle. Luminance measuring range/measuring diameter: “Specifications and Performance” of “6. Appendices”.
UP switch and DOWN switch	These switches move up/down the measurement data number indicated on the LC display unit. The measurement results are stored in the instrument’s memory up to 50 data.
ABS./DIF. Switch	Used to change the absolute value/difference to each other as the displayed data. The absolute value is displayed in the initial status.
LAMP switch	Turns ON/OFF the LC display unit illumination (back light). The illumination is ON in the initial status.

Functions of function mode

FUNCTION switch

Used to shift/reset to/from function mode. To shift to the function mode, press this switch for about 2 seconds. To reset from the function mode, it is not necessary to press the switch longer than usual.

ENTER switch

Used to change to the next page of the displayed data and to store data into memory after inputting numerical values.

CHANGE switch

Used to change the set values.

When pressing this switch, the displayed value is deleted and cursor blinks. Enter new data.

ROTATION switch

Used to select the setting contents. Each time you press this switch, the selectable candidates are displayed in order. The displayed contents are changed according to the parameter types.

Example: AUTO→FREQ→MANU→SYNC

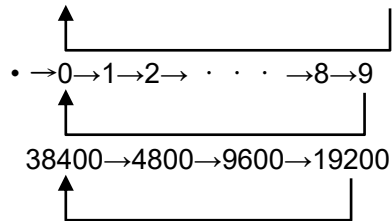

SHIFT switch

Used to shift to other digits when entering multiple-digit values. The cursor is moved from upper digit to lower digit.

LC display

- Initial screen

This screen appears when turning on the power and when pressing the reset switch.

```
*** Start SR-NIR***
```

- Screen displayed during measurement

This screen appears during measurement.

```
* Measuring *
IntegTime= 100
```

← Integral time: millisecond

- Measurement cancel

When pressing the [MEAS./HOLD] switch during measurement, the message shown below is displayed and measurement is stopped.

```
#10 AUTO ABS 2.0
                2.0
600nm=1.4834E+02
*Canceled Measuring
```

- Measured value display screen

This screen appears after measurement is finished.

Measurement number

Measurement mode

Absolute value measurement

Correction factor display
None: No correction
[f1]: Spectral correction is done.

Current measuring angle

Measuring angle when the displayed data was measured

Spectral radiance

Spectral radiance

When displayed with two lines



```
#10 AUTO ABS 2.0
                [f1] 2.0
600nm = 1.4468E+02
1030nm = 2.4466E+02
```

When displayed with one line

```
#10 AUTO ABS 2.0
                2.0
600nm = 1.4468E+02
```

1.3 Preparations

1.3.1 Connecting AC Adapter

 Mandatory	Be sure to use the AC adapter which is the standard or optional accessory. The defective AC adapter may cause fire or electric shock.
 Mandatory	Be sure to remove the dust or moisture around the plug and outlet of AC adapter. This may cause the fire.
 Prohibited	Never pull out or insert the plug by wet hand. This may cause electric shock.

Connect the AC adapter to the instrument by the following procedures.

1. Make sure that the instrument is turned OFF.

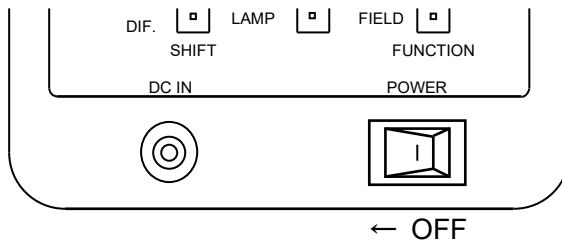

2. Insert the output connector of the AC adapter into the DC input connector on the instrument.

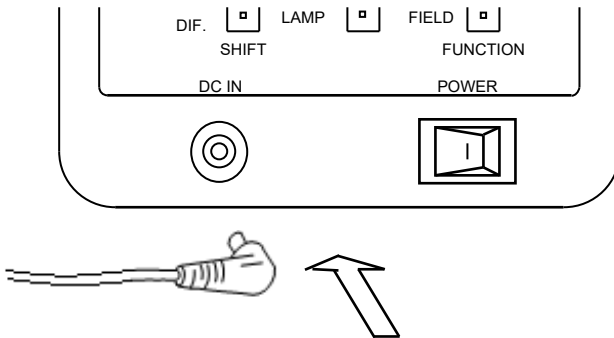

3. Connect the AC adapter plug to the outlet.

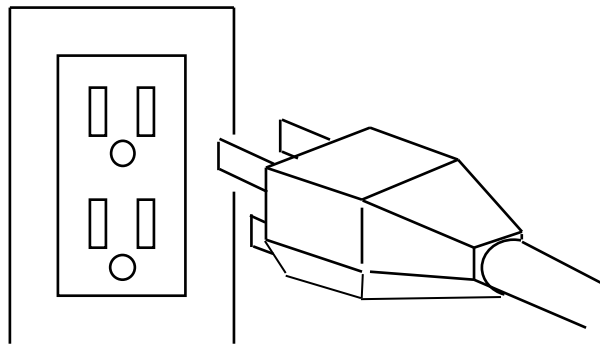

1.3.2 Connecting PC

When using SR-NIR by connecting to PC, connect the instrument to PC with RS-232C cable or USB cable. Use the RS-232C cable which is the interlink cable serial cross type applicable to the DOS/V personal computer.

The RS-232C signal line of this instrument is arranged according to the 9-pin D-SUB connector specification that is used in the DOS/V personal computer or others. When connecting the instrument to a computer, carry out wiring as referring to the drawing below.

Note

- The PC connection cable is not an accessory of the instrument. Please purchase the cable separately when you want to use it.
- When connecting to PC, refer to your PC manual in addition to the instrument's manual.



Remember

Do not connect/disconnect the connectors while the instrument is powered.

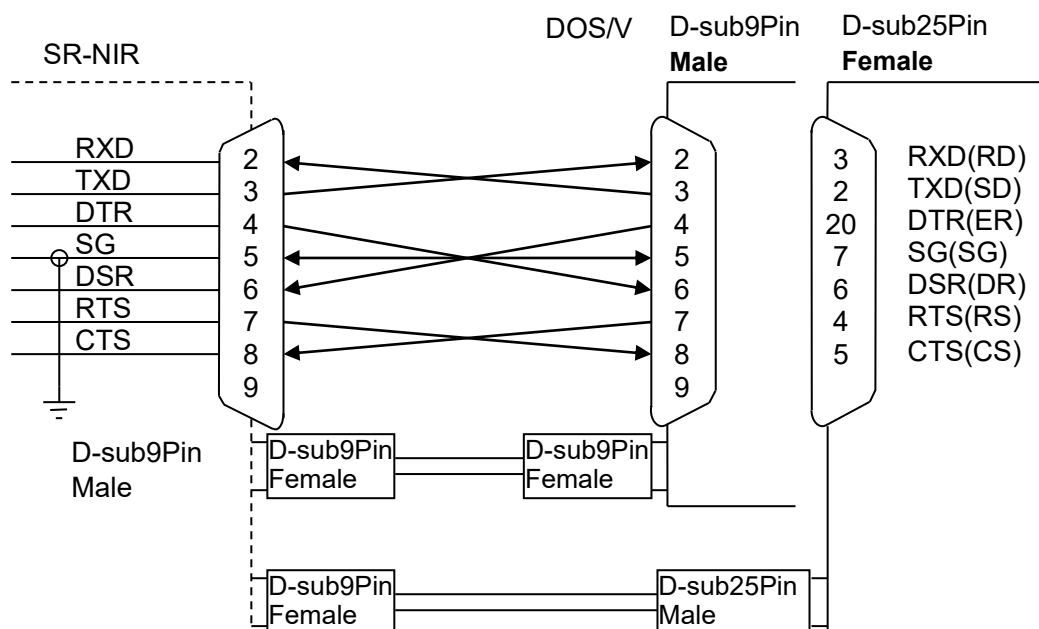



The RS-232C specifications of the instrument are shown below.

- Communication method Full duplex
- Synchronization Asynchronous communication
- Communication speed 4800/9600/19200/38400 BPS (Bits Per second)
- Bit configuration Data length: 7 bits/8 bits
Parity: Even number (EVEN)/Odd number (ODD)/None (NONE)
Stop bit: 1 bit/2 bits
- Communication type ASCII
- Delimiter: When data is sent, "CR+LF" or "CR" is set at the end of the communication data line.

Selection of terminal code of remote command: "3.8 Terminal Code of Remote Command".

1.3.3 Alignment of Measurement Target

 <p>Prohibited</p>	<p>Never watch the Sun or the filament of an electric bulb directly. This may injure your eyes.</p>
---	--

 <p>Remember</p>	<p>When using the tripod mounting screw hole or the jog mounting screw hole, use the specified screw. Do not tighten the screw excessively. The inside of the instrument may be broken.</p>
--	---

1. Fix this instrument by using the tripod mounting screw or the tool mounting screw.
2. Remove the objective lens cap. Set the viewfinder shutter selector knob to "OPEN".
3. Look into the eyepiece lens. Turn the diopter adjustment ring of the eyepiece lens to bring the reticle mark into focus.

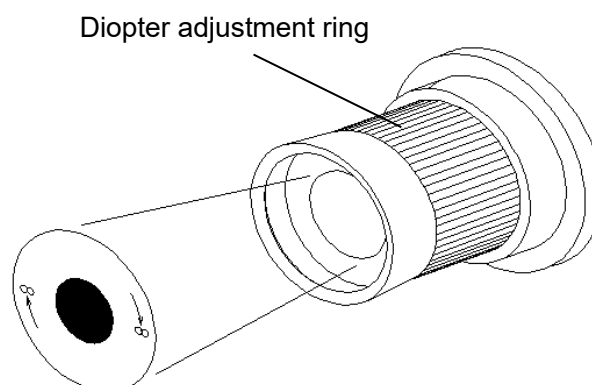
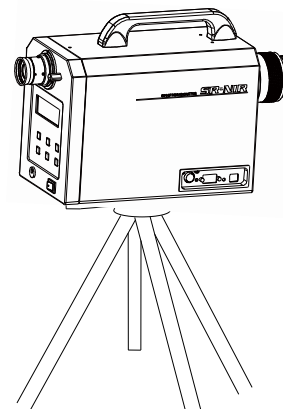

4. Perform alignment for the measurement target. Turn the focus adjustment ring of the objective lens to bring the measurement target into focus.
5. Change the measuring angle according to the size and brightness of the measurement target.

To change the measuring angle, use the [FIELD] switch.

Each time you press the [FIELD] switch, the angle is changed as shown below.

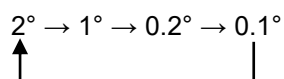

The current measuring angle is indicated on the LC display unit.

Display of LC display unit:  "1.2 Names and Functions of Components".

1.3.4 How to Turn On/Off the Power

To turn on the power, tilt the power switch rightward.

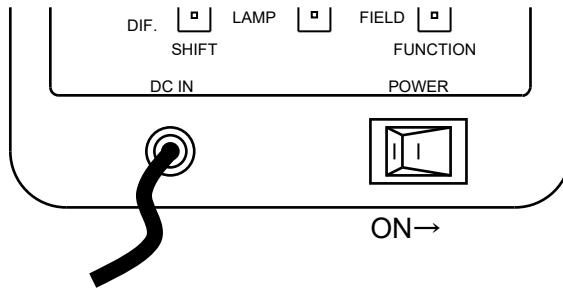

When the power is ON, the initial screen appears on the LC display unit. After the maintenance recommendation screen appears, the measured data is indicated last.

Display of the maintenance recommendation screen:

☞ “1.4 Maintenance Recommendation Display”.

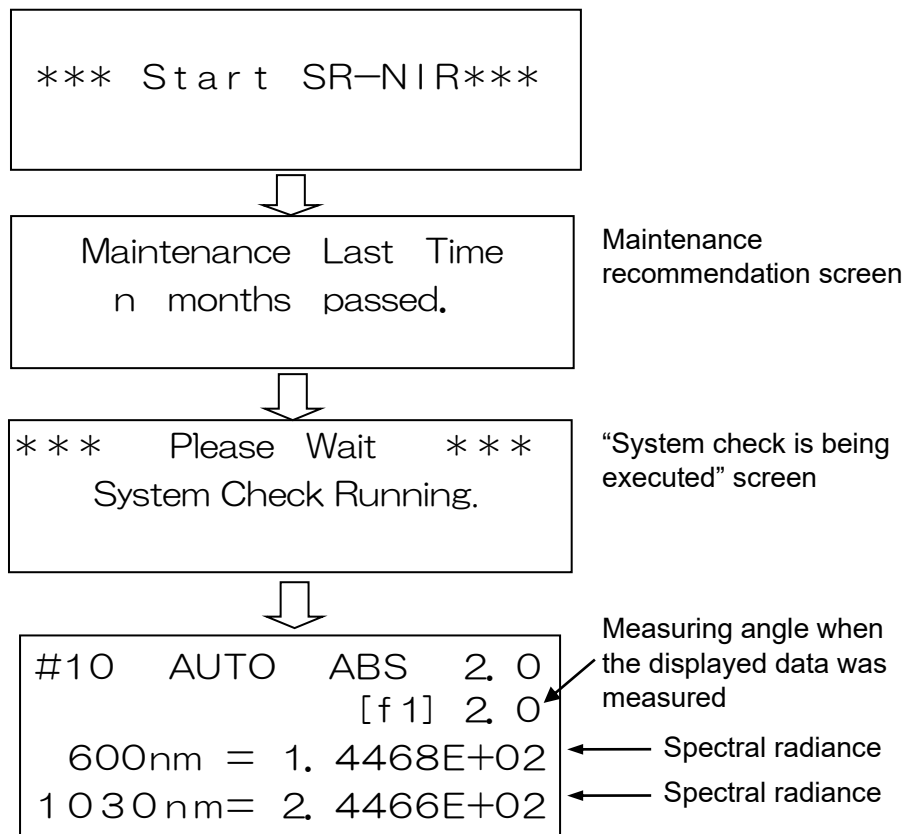

When displayed with two lines

 Remember	After turning on the power, perform warm-up for at least 40 minutes.
---------------------	--

To turn off the power, tilt the power switch leftward.

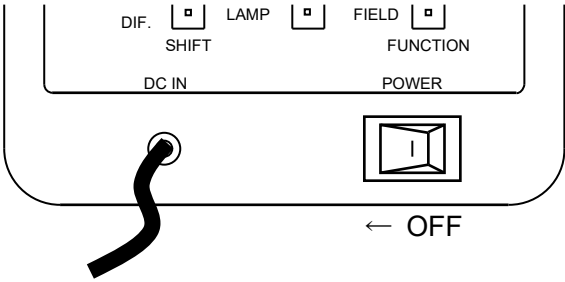

1.3.5 Opening/Closing the Viewfinder Shutter

When the brightness of the measurement target is extremely low or when there is a luminous body at the viewfinder side, set the viewfinder shutter to "CLOSE" in order to block the stray light from the viewfinder.

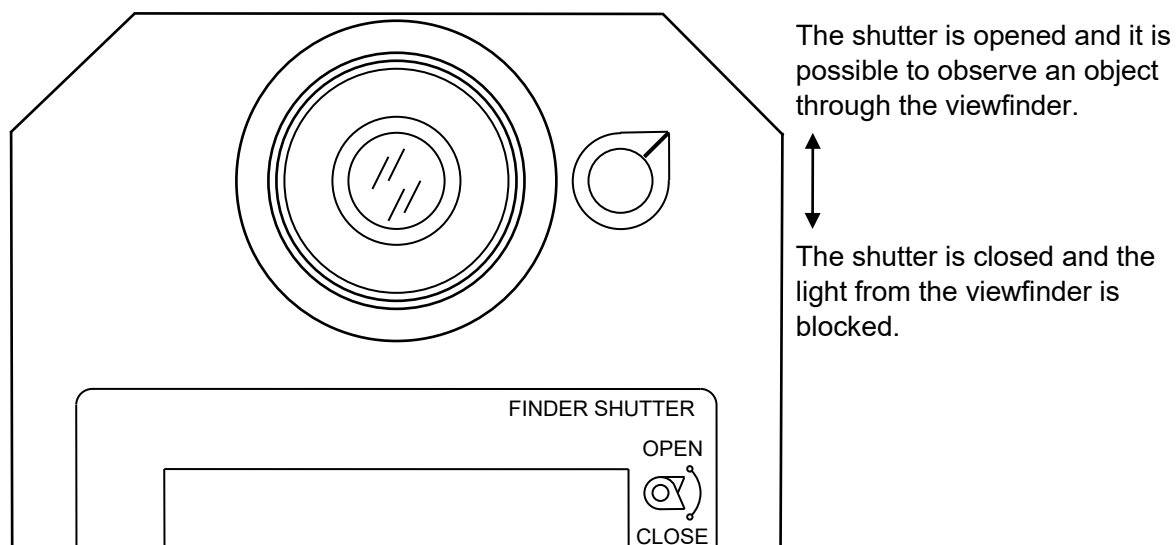

1.4 Maintenance Recommendation Display

In order to keep the measurement accuracy of this instrument, it is recommended to perform calibration at least once a year. When you turn on the instrument, the time lapse is displayed by the number of months since you purchased the instrument or the last calibration was done. (Fig. A) When one year has passed since the purchase or the last calibration, the message on Fig. B is displayed. Regard Fig. A and Fig. B as the standard for calibration.

Fig. A

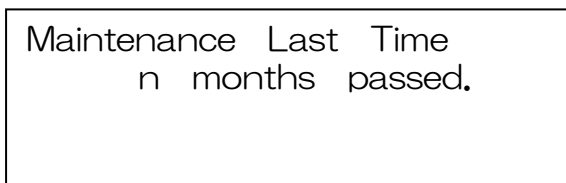

Maintenance Last Time
n months passed.

* "n" is the number of months showing the time lapse. (0 – 11)

Fig. B

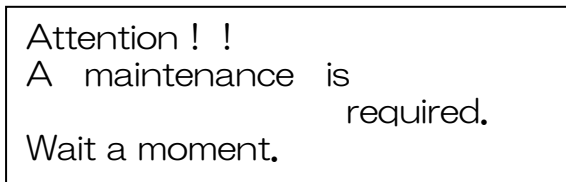

Attention !!
A maintenance is
required.
Wait a moment.

When Fig. B is displayed, you hear the beep sound for 5 seconds. Then, the screen shifts to the next one automatically.

When you want to hide this maintenance recommendation screen, set the maintenance recommendation display to "OFF".

Setting of the maintenance recommendation display:

 "3.14 Maintenance Recommendation Display".

2. Measurement Procedures

2.1 Single Measurement (Single)

The procedures to perform single measurement are described below.

 Remember	The measurement data is stored at the number next to the data number being indicated on the screen. When there is the data registered with the same number, the existing data is overwritten.
--	---

 Note
The measurement data can be stored up to 50.

1. Press the [MEAS./HOLD] switch to start measurement.

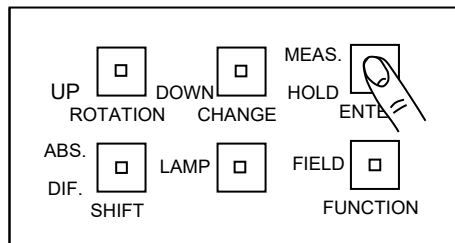

2. The integral time is indicated on the LC display unit and the instrument is in the measuring status.

Integral time:  "3.2 Measurement Mode".

```
* Measuring *  
IntegTime= 100
```

```
* Measuring *  
IntegTime= 100  
1cycle [ms] = 20
```

When "SYNC" is selected, the one cycle time of vertical synchronizing signal is also indicated.

3. When the measurement is finished, the measurement result is indicated. The indicated data is different according to the measurement modes.

Measurement mode:  "3.2 Measurement Mode".

#10	AUTO	ABS	2.0
		[f1]	2.0
600nm =	1.	4468E+02	
1030nm =	2.	4466E+02	

When "AUTO" is selected

#10	FREQ	ABS	2.0
		[f1]	2.0
600nm =	1.	4468E+02	
1030nm =	2.	4466E+02	

When "FREQ" is selected

#10	MANU	ABS	2.0
		[f1]	2.0
600nm =	1.	4468E+02	
1030nm =	2.	4466E+02	

When "MANU" is selected

#10	SYNC	ABS	2.0
		[f1]	2.0
600nm =	1.	4468E+02	
1030nm =	2.	4466E+02	

When "SYNC" is selected

Each time measurement is ended, the data number "#**" is increased.

2.2 Continuous Measurement (Auto Run)

The procedures to perform continuous measurement are described below.

 Remember	The measurement data is stored at the number next to the data number being indicated on the screen. When there is the data registered with the same number, the existing data is overwritten.
--	---

1. Change the measuring method to continuous measurement.

Setting of the measuring method:  "3.2 Measurement Mode".

2. Press the [MEAS./HOLD] switch.

 Note
<ul style="list-style-type: none">• In continuous measurement, the integral time is not indicated. Be careful for this difference compared with single measurement.• Each time measurement is ended, the data number "#**" is increased.

During measurement, "Run" is indicated at the data number section.

↓
Run AUTO ABS 2.0 [f1] 2.0 600nm = 1.4468E+02 1030nm = 2.4466E+02

3. To finish the measurement, press the [MEAS./HOLD] switch. "HOLD" on the panel switch is lit and the measurement result is indicated.

Run AUTO ABS 2.0 [f1] 2.0 600nm = 1.4468E+02 1030nm = 2.4466E+02

2.3 Difference Measurement

Using this instrument, you can measure the difference from the standard data.

The procedures to measure the difference are described below.

Change to the difference measurement.



Input or select the standard value.

The standard value can be stored up to 20 in this instrument.



Perform measurement.

1. Change the setting from "Absolute value measurement" to "Difference measurement".

Press the [ABS./DIF.] switch.

The display on the panel switch is changed to "DIF". The screen is changed as shown below and the standard value input/selection screen appears.

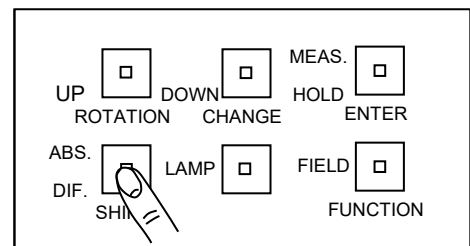

Standard value number

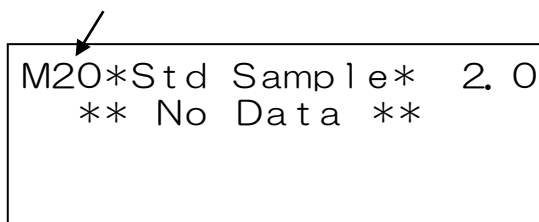

(When standard data is not registered)

2. Press the [MEAS./HOLD] switch to measure the standard value. After the measurement is finished, the measurement result is indicated and it is registered as the standard value.

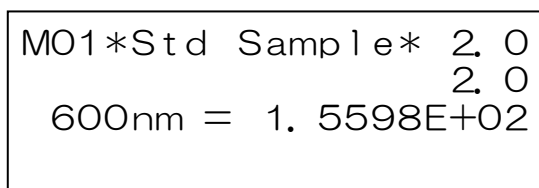

Each time you measure the standard value, the standard value number is increased and registered.

M01→M02→M03...M20 When the number reaches "20", it is returned to "01".



 Remember	<p>The standard value is registered at the number next to the number being indicated. When there is the data registered with the same number, the existing data is overwritten.</p>
--	---

3. When the standard values have already been registered, use the [UP] and [DOWN] switches to select a desired number for the new standard value.

4. Press the [FIELD] switch to decide the standard value. The normal screen appears again.

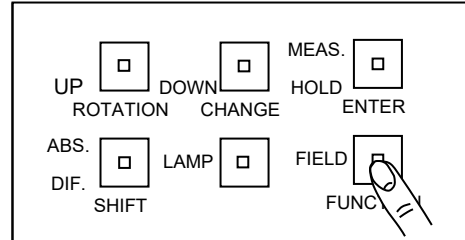

5. Measure the color difference.

Perform the measurement in the same way as absolute value measurement. It is possible to change the measurement mode and to perform continuous measurement.

Changing the measurement mode:  "3.2 Measurement Mode".

Continuous measurement:  "2.2 Continuous Measurement (Auto Run)".

After the measurement is finished, the difference is indicated.

#10	AUTO	DIF	2.0
			2.0
600nm=-4.8688E-01			

 Remember	<p>To change the standard value number or input the standard value data, press the [ABS/DIF] switch to return to "ABS" (absolute value measurement). Then, press the [ABS/DIF] switch again to change to "DIF" (difference measurement) and perform the procedures from Step 1.</p>
--	---

2.4 Display of Measurement Data

The measurement data is numbered and is stored in the internal memory up to 50.

You can see the stored data with the [UP] and [DOWN] panel switches. Press the [UP] switch, and the data with the next number is indicated. Press the [DOWN] switch, and the data with the preceding number is indicated.

 Remember	When you press the [MEAS./HOLD] switch to perform measurement while some data is being indicated, the measured data is stored at the number next to the data being indicated. When there is the data registered with the same number, the existing data is overwritten.
--	---



All measurement data can be deleted at a time.

 “3.16 Batch Deletion of Measurement Data/DIF Standard Data”.

2.5 Measuring

In this chapter, a measurement example will be described. Please use the example as a reference when you use this instrument.

2.5.1 Measuring Directional Light Sources

When measuring a light source with directivity (for example, LED) or a light source with unevenness, use a white board for measurement as shown in the figure. If you observe the light source directly, sometimes you cannot obtain the data with good repeatability.

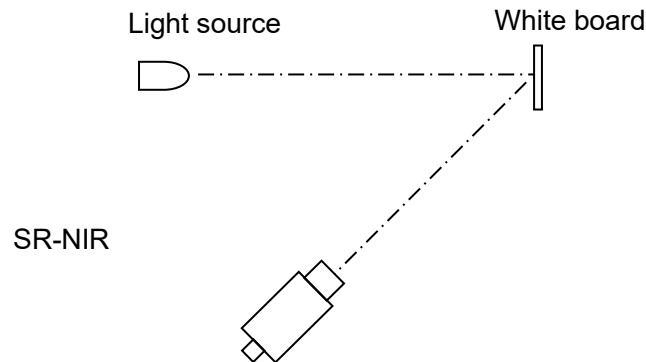

2.5.2 Measuring Very Small Surfaces

When measuring a smaller sample than the instrument's measuring diameter, use the attachment lens, which is an optional accessory. There are two types of attachment lens, "AL-6" and "AL-11".

Measuring diameter of SR-NIR: "Specifications and Performance" of "6. Appendices".

Use the screw at the objective lens end of this instrument to connect the attachment lens.

When using the attachment lens, it is necessary to set the correction factor in the instrument.

Setting the correction factor: "3.9 Using Correction Factor" and "3.10 Display/Change of Correction Factor".

The measuring diameter of each measuring angle is shown in the tables below.

In the case of AL-6

Measuring angle	Measuring diameter (mm)
2°	2.00 – 2.88
1°	1.00 – 1.44
0.2°	0.20 – 0.29
0.1°	0.10 – 0.14

* Measuring distance: 51.72 – 68.53mm
(from the hardware tip)

In the case of AL-11

Measuring angle	Measuring diameter (mm)
2°	1.18 – 1.53
1°	0.59 – 0.76
0.2°	0.19 – 0.15
0.1°	0.06 – 0.08

* Measuring distance: 19.56 – 24.80mm
(from the hardware tip)

2.5.3 System Integration

You can incorporate this instrument into one system and use it under the incorporated status. To use the instrument under the incorporated status in system, refer to the following chapters.

Communication specification:  "4.Communication with PC".

Installation data:  "External Dimensional Diagram" of "6. Appendices"

2.5.4 Measuring a Frequency Light Source

To measure a light source lighting by frequency, follow the procedures described below.

■ When measuring with "FREQ" (frequency) mode

When the lighting frequency of the light source is known, set the measurement mode to "FREQ" (frequency). Input the frequency and measure the light source.

 "3.2 Measurement Mode".

In "FREQ" mode, the integral time is automatically set to the value obtained by multiplying one cycle by integers. So the discrepancy can be reduced in measurement.

■ When measuring with "AUTO" mode

When measuring a light source equipped with a high duty ratio and a high light intensity or a light source where a dummy (black) enters during the lighting cycle period by using "AUTO" mode, the sufficient flashing times cannot be obtained in the set integral time and so big discrepancy occurs in the measured values. (Refer to the following example.) Setting the integral time longer than usual is useful to reduce discrepancy. By using the integral time delay function, the integral time is longer and measurement is done in stabilized condition.

 "3.3 Integral Time Delay Function".

Set the measurement mode to "AUTO", set the integral time delay function to ON and set the delay time.

We recommend approx. 100 cycles or more as the delay time.

Example: When discrepancy 10% of one cycle occurs (Refer to the following figure.)

- Measure with the integral time of 10 cycles (t : One cycle time).

$$\text{Discrepancy} = 0.1 t / 10 t = 1\%$$

- Measure with the integral time of 100 cycles.

$$\text{Discrepancy} = 0.1 t / 100 t = 0.1\%$$

Setting the longer integral time reduces discrepancy.

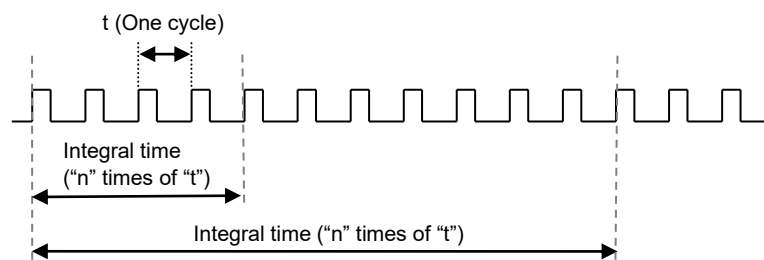

















3. Settings

3.1 Function Mode

3.1.1 Setting Items

In this instrument, you can perform the following settings by function mode.

- Selection of measurement mode  "3.2 Measurement Mode".
- Setting of frequency (in "FREQ" mode)  "3.2.1 FREQ (Frequency) Mode".
- Setting of integral time (in "MANU" mode)  "3.2.2 MANU (Manual) Mode".
- Use of the integral time delay function  "3.3 Integral Time Delay Function".
- Setting of delay time  "3.3.1 Setting Delay Time".
- Selection of measurement method  "3.4 Single or Auto Run".
- Selection of PC connection method  "3.5 PC Connection Method".
- Setting of RS-232C parameters  "3.6 RS-232C Parameters".
- Selection of data communication method  "3.7 Data Communication Method".
- Selection of the remote command terminal code  "3.8 Terminal Code of Remote Command".
- Use of correction factor  "3.9 Using Correction Factor".
- Display/change of correction factor  "3.10 Display/Change of Correction Factor".
- Selection of average measurement  "3.11 Average Measurement".
- Setting of average times  "3.11.1 Average Times".
- Selecting "OVER-RANGE" detection in "MANU" mode  "3.12 Selecting "OVER-RANGE" Detection in "MANU" Mode
- Use of beep sound  "3.13 Beep Sound".
- Setting of maintenance recommendation display  "3.14 Maintenance Recommendation Display".
- Use of auto panel light  "3.15 Setting Auto Panel Light".
- Batch deletion of measurement data/DIF standard data  "3.16 Batch Deletion of Measurement Data/DIF Standard Data".

3.1.2 Entering/Returning from the Function Mode

■ Function menu

Using the function mode, perform a variety of settings.

Shifting to the function mode and the setting items are described below.

Make sure that the instrument is in the standby condition. Then, press the [FUNCTION] panel switch for about 2 seconds. When you hear the beep sound, release the switch.

The system shifts to the function mode.

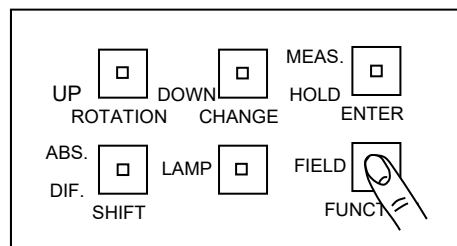

Note

If you release the switch before the beep sound occurs, the system does not shift to the function mode. Be sure to keep pressing the switch until the beep sound occurs.

Function mode menu screen

```
*MEASURE      MAINTAIN
  FACTOR
  COMM.
  DISPLAY
```

When pressing the [ROTATION] switch or [CHANGE] switch on the panel, “*” is moved. Fit “*” to a desired item and press the [ENTER] switch to decide the item. The setting items in each function mode are displayed.

The setting items of each function mode are described below.

(1) MEASURE: This is relevant to measurement.

- ① Measure Type : Set the measurement mode. ☞ “3.2 Measurement Mode”.
- ② Frequency Input : Set the frequency for “FREQ” measurement mode. When “FREQ” is selected in ① of (1), this item is displayed. ☞ “3.2.1 FREQ (Frequency) Mode”.
- ③ Integ Time Input : Set the integral time for “MANU” mode. When “MANU” is selected in ① of (1), this item is displayed. ☞ “3.2.2 MANU (Manual) Mode”.
- ④ Integ Delay ON/OFF : Set “Valid/Invalid” of the integral time delay function. ☞ “3.3 Integral Time Delay Function”.

- ⑤ Integ Delay Time : Set the delay time. When “ON” is selected in ④ of (1), this item is displayed.
☞ “3.3.1 Setting Delay Time”.
- ⑥ Single or Auto Run : Set the measurement method.
☞ “3.4 Single or Auto Run”.
- ⑦ AverageMeas ON/OFF : Set whether the average measurement function is used or not.
☞ “3.11 Average Measurement”.
- ⑧ Average time : Set the average times. When “Average Meas” is selected in ⑦ of (1), this item is displayed.
☞ “3.11.1 Average Times”.

(2) FACTOR: This is relevant to correction factor.

- ① Factor (1nm) ON/OFF : Set “Valid/Invalid” for the use of correction factor.
☞ “3.9 Using Correction Factor”.

(3) COMM: This is relevant to communication.

- ① Communication – Type : Set the data communication method (USB/RS-232C).
☞ “3.5 PC Communication Method”.
- ② RS-232C Parameters : Set the RS-232C parameters. When “RS-232C” is selected in ① of (3), this item is displayed.
☞ “3.6 RS-232C Parameters”.
- ③ Handshake ON/OFF : Set the data communication method. When “RS-232C” is selected in ① of (3), this item is displayed.
☞ “3.7 Data Communication Method”.
- ④ Delimiter : Set the command terminal code when communicating with PC.
☞ “3.8 Terminal Code of Remote Command”.

(4) DISPLAY: This is relevant to the display on the LC display unit.

- ① Auto Panel Light : Set “Valid/Invalid” for the use of auto panel light.
☞ “3.15 Setting Auto Panel Light”.
- ② Beep ON/OFF : Set whether the beep sound should occur or not.
☞ “3.13 Beep Sound”.

3.1.3 Setting Numerical Value

In the function mode, there are items into which numerical values should be input. The procedures to input numerical values are same in all the items.

The setting of integral time (in “MANU” mode”) will be explained as an example.

1. Shift to the function mode, select [MEASURE] from the function menu and press the [ENTER] switch. The following screen appears.

☞ “3.1.2 Entering/Returning from the Function Mode”.

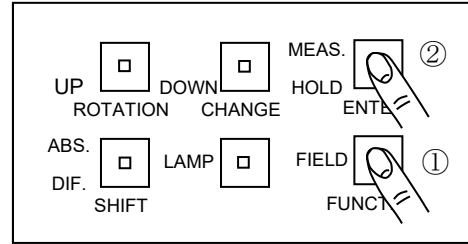
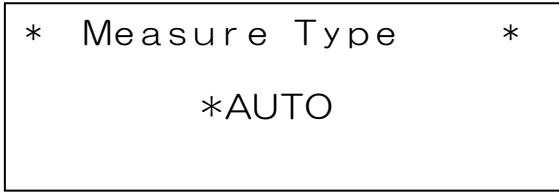

2. Press [CHANGE]. The cursor is lit and the system is in the standby status.

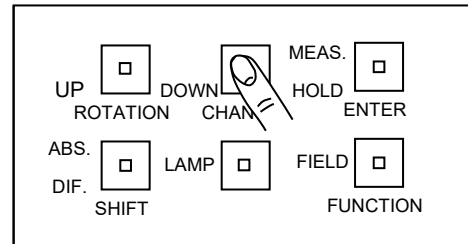
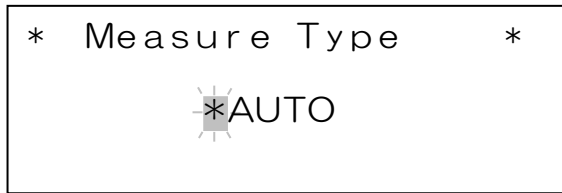

3. Press the [ROTATION] switch, change the measurement mode to “MANU”, and press the [ENTER] switch to decide the change. Each time you press the [ROTATION] switch, the mode is changed as shown below.

☞ “3.2 Measurement Mode”.

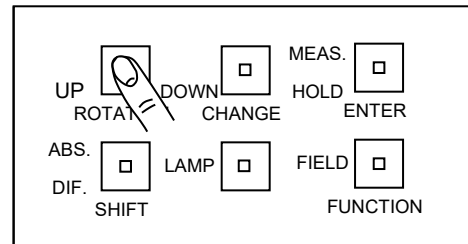
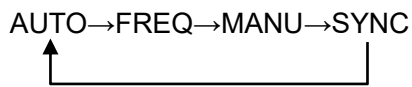

4. Press the [ENTER] switch again. The screen shown below appears.

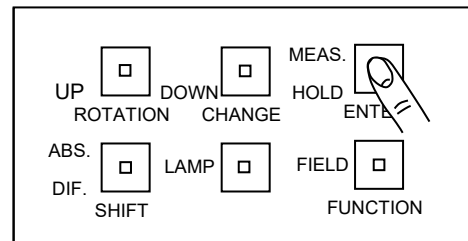
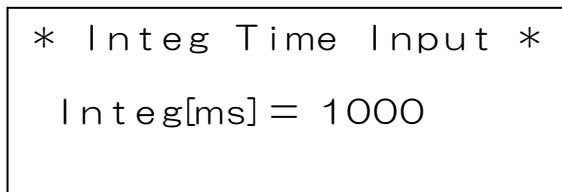

5. Press the [CHANGE] switch.

The cursor is lit and the system is in the standby status.

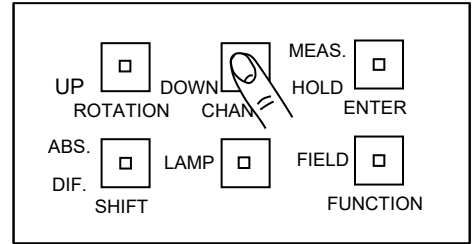
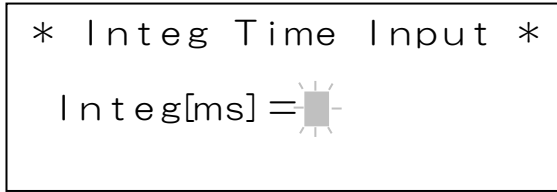

6. Each time you press the [ROTATION] switch, a numerical value is displayed. Press the [ROTATION] switch until a desired value is displayed.

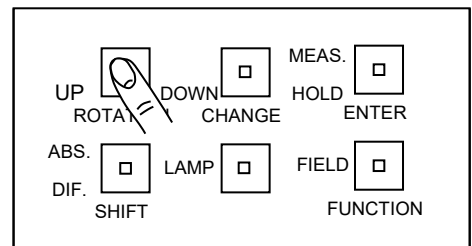
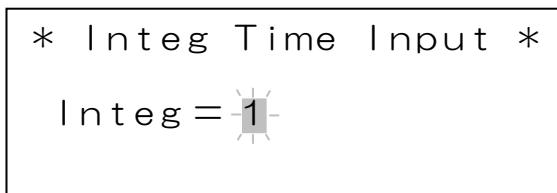

7. Press the [SHIFT] switch to shift to the next digit.

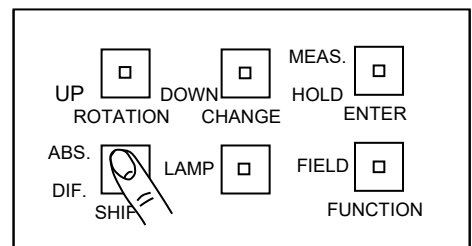
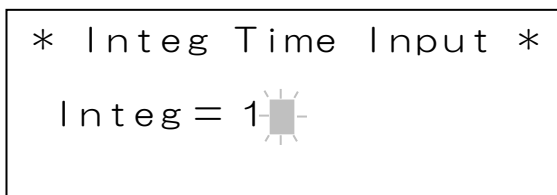

8. Repeat Step 6 and Step 7 to input your desired numerical value.

9. After inputting, press the [ENTER] switch to decide the numerical value.

Note

- If you input a value out of the specified range, the system returns to Step 5. Input a value again.
- If you make a mistake during the input process, perform the work until Step 9. Then, carry out the procedures from Step 5 again.

3.2 Measurement Mode

Set the measurement mode.



In this instrument, there are four selectable measurement modes for the light source to be measured. The integral time calculation method is different among the measurement modes.

Note

Integral time is the time to expose the sensor in light. Within the integral time, the optical energy is accumulated in the sensor. The integral time is different from the measurement time. Measurement time is calculated by the following formula.

Measurement time = Integral time × 2 + Shutter opening/closing time + Calculation time

The measurement modes of this instrument are described below.

- AUTO Used to measure normal light. The optimal integral time is automatically set according to the brightness of the light source to be measured.
- FREQ Used to measure CRT, fluorescent light, and other lighting objects. Set the vertical synchronizing signal for CRT and the commercial frequency (50 or 60Hz) for the fluorescent light and other lighting objects. The optimal integral time is calculated according to the input frequency and the light source brightness. The input range is 10 - 250Hz.
Input of frequency:  "3.2.1 FREQ (Frequency) Mode".
- MANU Set an optional integral time and perform measurement. The input range is 20 – 15000ms.
Input of integral time:  "3.2.2 MANU (Manual) Mode".



Remember

When a shorter integral time is set in "MANU" mode than the integral time calculated in "AUTO" mode, sometimes the measurement accuracy is lowered.

- SYNC When measuring CRT, carry out "Line input" of the vertical synchronizing signal to SR-NIR. Then, use it for measuring. The optimal integral time is calculated according to the input frequency and the light source brightness. The frequency detection range is 10 – 250Hz.

The procedures to set the measurement mode are described below.

1. Shift to the function mode. Access [MEASURE] from the function menu. Then, access the [Measure Type] screen.

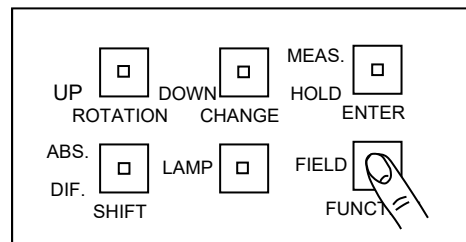

 "3.1.2 Entering/Returning from the Function Mode"

3.2.1 FREQ (Frequency) Mode

When selecting “FREQ” as the measurement mode, set the frequency of the light source to be measured.

The setting procedures are described below.

1. Shift to the function mode. Access [MEASURE] from the function menu. Then, access the [Frequency Input] screen.

 "3.1.2 Entering/Returning from the Function Mode"

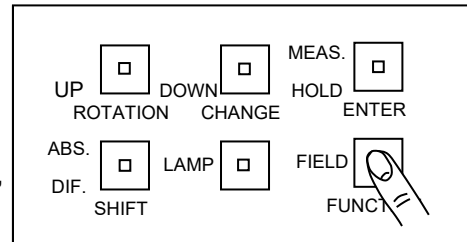

2. Press the [CHANGE] switch.
3. Input the desired numerical value according to the numerical value input method.
You can input numerical values within the “10 – 250 (Hz)” range.

Setting method:  “3.1.3 Setting Numerical Value”.

```
* Frequency Input *  
Freq [Hz] = 50
```

4. Press the [ENTER] switch to decide the value.

3.2.2 MANU (Manual) Mode

When selecting “MANU” as the measurement mode, set the integral time.
Input the integral time to be used in “MANU” mode.

- 1. Shift to the function mode. Access [MEASURE] from the function menu. Then, access the [Integ Time Input] screen.

☞ “3.1.2 Entering/Returning from the Function Mode”.

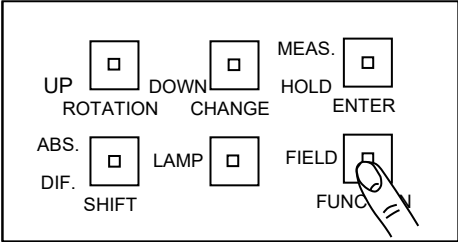

- 2. Press the [CHANGE] switch.
- 3. Input the desired numerical value according to the numerical value input method. You can input the numerical values within the “20 – 15000ms” range.

Setting method: ☞ “3.1.3 Setting Numerical Value”.

```
* Integ Time Input *  
Integ [ms] = 100
```

- 4. Press the [ENTER] switch to decide the value.

3.3 Integral Time Delay Function

Set whether the integral time delay function should be used or not. It is effective to use this function as described below.

When measuring a light source equipped with a high duty ratio and a high light intensity or a light source where a dummy (black) enters during the lighting cycle period by using "AUTO" mode, the sufficient flashing times cannot be obtained in the set integral time and so big discrepancy occurs in the measured values. Setting the integral time longer than usual is useful to reduce discrepancy. By using the integral time delay function, the integral time is longer and measurement is done in stabilized condition.

☞ "2.5.4 Measuring a Frequency Light Source".

The setting procedures are described below.

1. Shift to the function mode. Access [MEASURE] from the function menu. Then, access the [Integ Delay ON/OFF] screen.

☞ "3.1.2 Entering/Returning from the Function Mode".

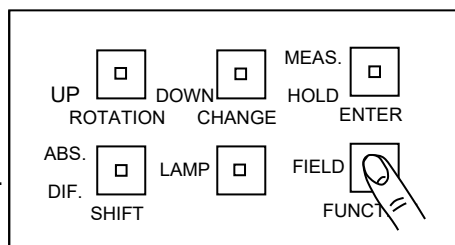

2. Press the [CHANGE] switch.
3. Press the [ROTATION] switch. ON/OFF is changed to each other.

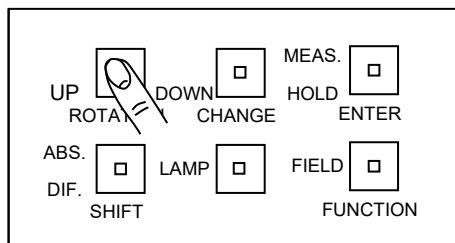

4. Press the [ENTER] switch to decide ON or OFF.

3.3.1 Setting Delay Time

When the integral time delay function is set to “ON”, set the integral time.

Note

It is recommended to set 100 cycles or more as the integral time.

Example: When measuring the light source with the cycle discrepancy 10%:

When measuring with the integral time of 10 cycles, the discrepancy is as follows.

$$0.1t/10t = 1\% \text{ (“t” is the cycle time.)}$$

When measuring with the integral time of 100 cycles, the discrepancy is as follows.

$$0.1t/100t = 0.1\%$$

The setting procedures are described below.

Setting

1. Shift to the function mode. Access [MEASURE] from the function menu. Then, access the [Integ Delay Time] screen.

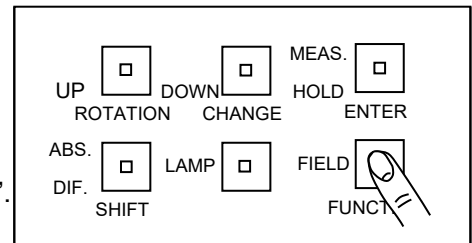

☞ “3.1.2 Entering/Returning from the Function Mode”.

Integ Delay Time
Integ [ms] = 1000

2. Input the desired numerical value according to the numerical value input method. You can input the numerical values within the “50 – 3000 [ms]” range.

Setting method: ☞ “3.1.3 Setting Numerical Value”.

Integ Delay Time
Integ [ms] = 50

3. Press the [ENTER] switch to decide the value.

3.4 Single or Auto Run

Set the measuring method.

There are two measuring methods, "Single" (single measurement) and "Auto run" (continuous measurement).

Measuring method	
Single (single measurement)	Press the [MEAS./HOLD] switch. The instrument performs measurement once and finishes the work.
Auto Run (continuous measurement)	Press the [MEAS./HOLD] switch. The instrument performs measurement continuously until the [MEAS./HOLD] switch is pressed again.

The procedures to set the measuring method are described below.

1. Shift to the function mode. Access [MEASURE] from the function menu. Then, access the [Single or Auto Run] screen.

☞ "3.1.2 Entering/Returning from the Function Mode".

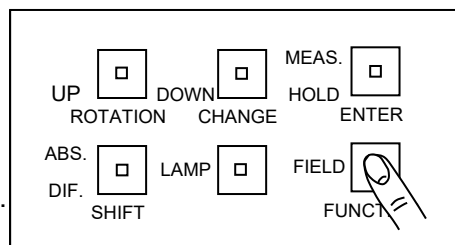

```
*Single or Auto Run*
*Single
```

2. Press the [CHANGE] switch.
3. Press the [ROTATION] switch to change to the desired measuring method.
Each time you press the [ROTATION] switch, the display is changed as shown below.

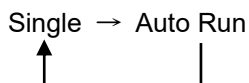

4. Press the [ENTER] switch to decide the measuring method.

3.5 PC Connection Method

Set the connecting method for this instrument and PC. This setting is necessary when using the instrument by connecting to PC.

The setting procedures are described below.

1. Shift to the function mode. Access [COMM.] from the function menu. Then, access the [Communication-Type] screen.

☞ “3.1.2 Entering/Returning from the Function Mode”.



2. Press the [CHANGE] switch.
3. Press the [ROTATION] switch to select the desired connecting method.
Each time you press the [ROTATION] switch, the display is changed as shown below.

USB → RS-232C
↑

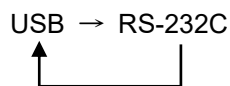

A diagram illustrating the effect of the [ROTATION] switch. It shows 'USB' on the left and 'RS-232C' on the right, connected by a horizontal arrow pointing right. Below 'USB', there is an upward-pointing arrow, and a vertical line extends from the bottom of this arrow to the bottom of the horizontal arrow, indicating a rotation of the display.

4. After selecting, press the [ENTER] switch.
5. To validate the setting, press the reset button of the instrument.

3.6 RS-232C Parameters

Set the parameters of RS-232C interface. This setting is necessary when connecting the instrument to PC through the RS-232C cable.

Set the RS-232C parameters in the function mode.

In the following example, “Baud rate: 9600, Data length: 8, Parity: None, Stop bit: 2” will be changed to “Baud rate: 38400, Data length: 7, Parity: Odd number, Stop bit: 1”.

The setting procedures are described below.

 **Note**

When “USB” is set in “3.5 How to Connect PC”, the RS-232C parameters setting screen is not indicated.

1. Shift to the function mode. Access [COMM.] from the function menu. Then, access the [RS-232C Parameters] screen.

 “3.1.2 Entering/Returning from the Function Mode”.

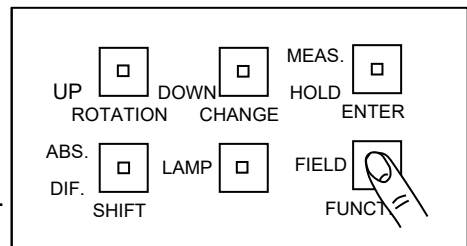

```
*RS-232C Parameters*
Baud rate= 9600
Length=8 Parity=NONE
Stop bit= 2
```

2. To set the parameters, press the [CHANGE] switch. The part of the parameters, which can be changed, blinks.

```
*RS-232C Parameters*
Baud rate= 9600
Length=8 Parity=NONE
Stop bit= 2
```

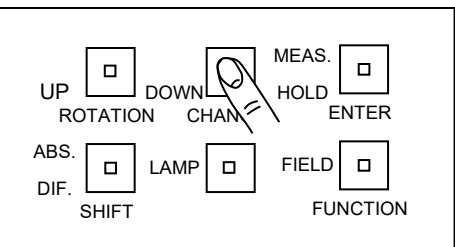

3. Press the [ROTATION] switch to change the baud rate to 38400.

```
*RS-232C Parameters*
Baud rate= 9600
Length=8 Parity=NONE
Stop bit= 2
```

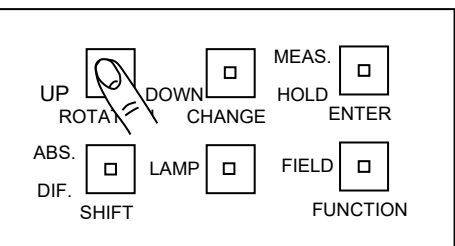

Baud rate is changed in the following order.

38400 → 4800 → 9600 → 19200

4. Press the [ENTER] switch. The baud rate is decided and the cursor is moved to data length.

```
*RS-232C Parameters*
Baud rate= 38400
Length=8 Parity=NONE
Stop bit= 2
```

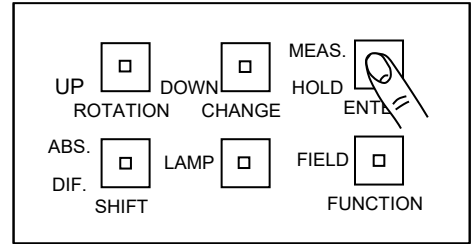

5. Press the [ROTATION] switch to change the data length to 7 and decide it with the [ENTER] switch.

The cursor is moved to parity.

```
*RS-232C Parameters*
Baud rate= 38400
Length=7 Parity=NONE
Stop bit= 2
```

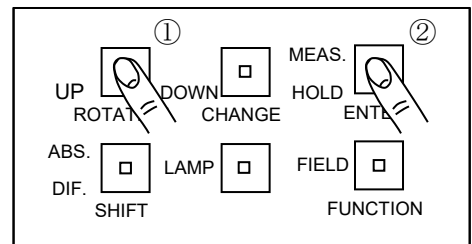

6. Press the [ROTATION] switch to change parity to "ODD" and decide it with the [ENTER] switch.

The cursor is moved to stop bit.

```
*RS-232C Parameters*
Baud rate= 38400
Length=7 Parity=ODD
Stop bit= 2
```

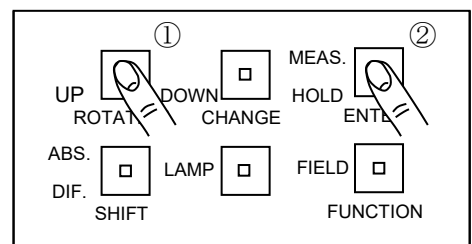

7. Press the [ROTATION] switch to change the stop bit to 1 and decide it with the [ENTER] switch.

The cursor disappears and the setting is completed.

```
*RS-232C Parameters*
Baud rate= 38400
Length=7 Parity=ODD
Stop bit= 1
```

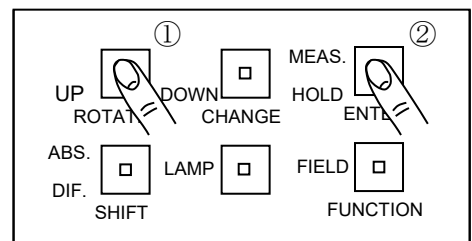

3.7 Data Communication Method

In this instrument, there are two methods to output the measurement data.

One method is provided to communicate with the remote measurement tool, which is the communication software as the accessory of this instrument. In the case of this method, handshaking is performed to check data errors. (Handshake Type)

In the case of the other method, data are sent continuously from the first to the last. (Normal Type)

The details of communication will be explained in the section of ST command of the chapter about communication command.

In this chapter, the setting method in the function mode will be described.

 **Note**

When “USB” is set in “3.5 PC Connection Method”, the setting screen for the data communication method is not indicated.

1. Shift to the function mode. Access [COMM.] from the function menu. Then, access the [Handshake ON/OFF] screen.

 “3.1.2 Entering/Returning from the Function Mode”

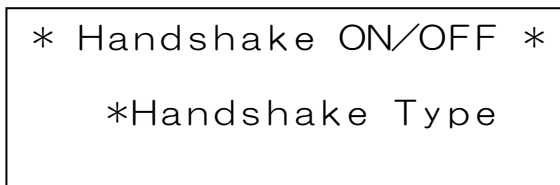
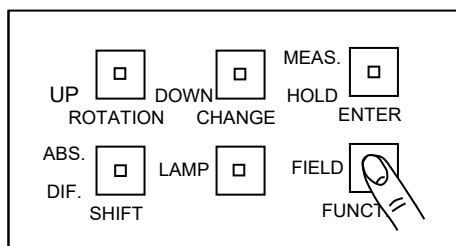

2. Press the [CHANGE] switch.
3. Press the [ROTATION] switch to select the desired method.

Each time you press the [ROTATION] switch, the display is changed as shown below.

Handshake Type → Normal Type



4. After selecting, press the [ENTER] switch.

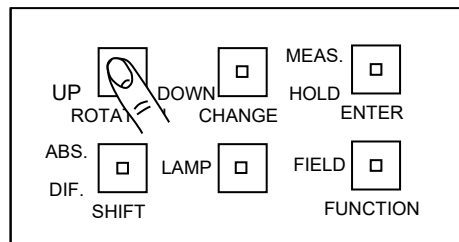
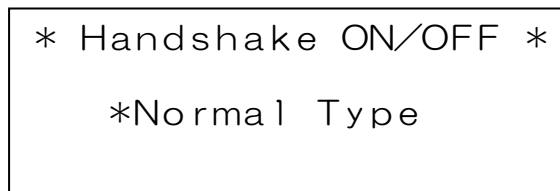

3.8 Terminal Code of Remote Command

Set the terminal code of the command when communicating with PC.

The setting procedures are described below.

1. Shift to the function mode. Access [COMM.]. Then, access the [Delimiter] screen.

☞ “3.1.2 Entering/Returning from the Function Mode”.



2. Press the [CHANGE] switch.
3. Press the [ROTATION] switch to select the desired terminal code.
Each time you press the [ROTATION] switch, the display is changed as shown below.

CR+LF → CR
↑

4. After selecting, press the [ENTER] switch.

3.9 Using Correction Factor

Set whether correction factor should be used or not.

When the measured value is multiplied by correction factor, the value is corrected.

The measured value is corrected as the spectral data per 1nm. A pair of correction factors is used.

Set ON (Used) or OFF (Not used).

The setting procedures are described below.

1. Shift to the function mode. Access [FACTOR] from the function menu. Then, access the [Factor ON/OFF] screen.

 "3.1.2 Entering/Returning from the Function Mode".

* Factor ON/OFF *

Factor (1nm) = *OFF

2. Press the [CHANGE] switch.
The right part of "Factor (1nm)" blinks.
3. Press the [ROTATION] switch to select ON or OFF.
Each time you press the [ROTATION] switch, ON and OFF are changed to each other.

 Note

When it is not necessary to change the displayed data, do not press the [ROTATION] switch but proceed to Step 4.

4. After selecting, press the [ENTER] switch.

3.10 Display/Change of Correction Factor

In the function mode, you can set whether correction factor should be used or not.

■ Setting whether correction factor should be used or not

1. Shift to the function mode. Access [FACTOR] from the function menu. Then, access the [Factor ON/OFF] screen.

☞ “3.1.2 Entering/Returning from the Function Mode”.

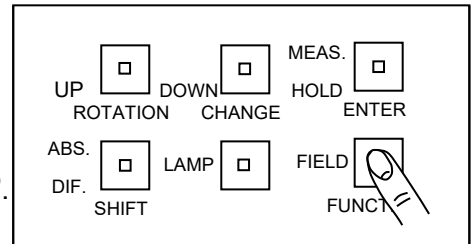

```
*      Factor ON/OFF      *
Factor (1nm) = *OFF
```

2. To change the setting, press the [CHANGE] switch. The part after “Factor (1nm) =” lights up.

```
*      Factor ON/OFF      *
Factor (1nm) = *OFF
```

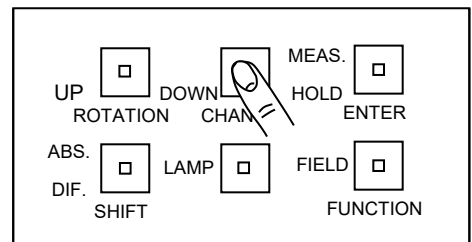

3. Each time you press the [ROTATION] switch under this status, ON and OFF are changed to each other.

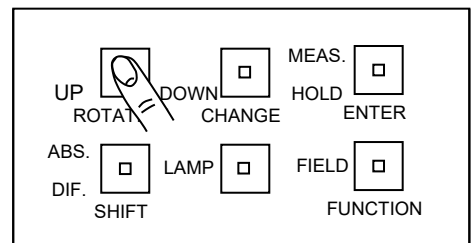

4. To decide the setting, press the [ENTER] switch.

```
*      Factor ON/OFF      *
Factor (1nm) = *OFF
```

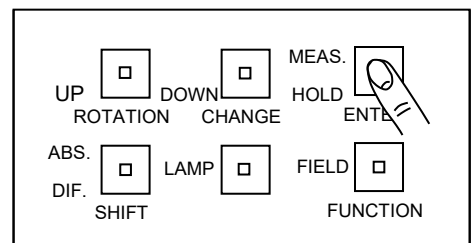

■ Input of correction factor by using the correction factor tool

1. Connect the PC and the USB cable or RS-232C cable (interlink cable serial cross type applicable to DOS/V personal computer).

 "1.3.2 Connecting PC".

 "3.5 PC Connection Method".

 "3.6 RS-232C Parameters".

2. Using the accessory correction factor tool, send/store the correction factor to the instrument.
For details, refer to the correction factor tool's instruction manual.

Note

When you (customer) create a program, please refer to the chapter about KW [n] command.

 "4.1.5 KW [n] Command".

3.11 Average Measurement

Set whether average measurement should be performed or not.

Normal Meas: Average measurement is not done.

Average Meas: Average measurement is done.

In average measurement, the average value of the measured values obtained by measuring two or more times is regarded as the measured value to perform measurement with low luminance more accurately. The more times averaging is carried out, the longer the measuring time is.

Measuring time

$$= \text{Integral time} \times (\text{Times of averaging} + 1) + \text{Integral time} + \text{Shutter operating time} + \text{Processing time}$$

Setting whether average measurement should be done or not

- Shift to the function mode. Access [MEASURE] from the function menu. Then, access the [AverageMeas ON/OFF] screen.

☞ “3.1.2 Entering/Returning from the Function Mode”.

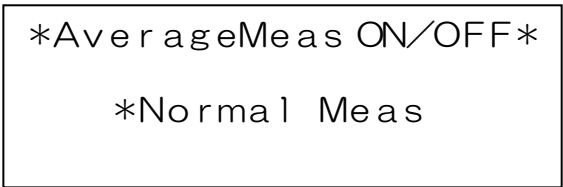
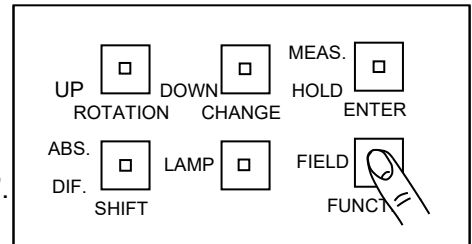

- To change the setting, press the [CHANGE] switch. Press the [ROTATION] switch to change “Normal Measure” and “Average Measure” to each other. “Normal Meas” is changed to “Average Meas” and vice versa.

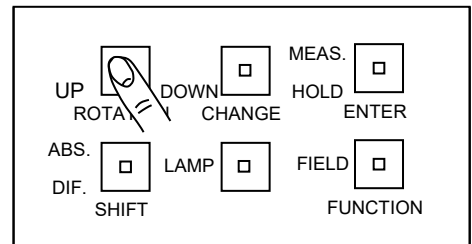
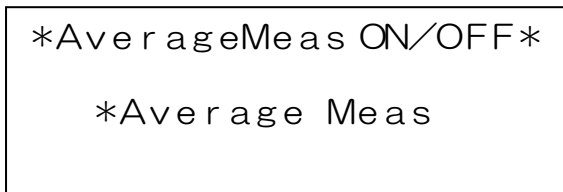

3.11.1 Average Times

1. Shift to the function mode. Access [MEASURE] from the function menu. Then, access the [Average Time] screen.

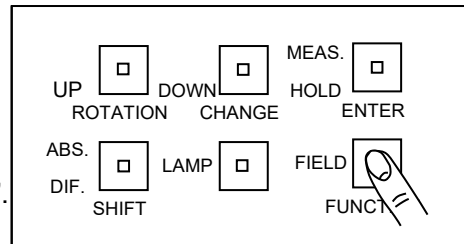

☞ “3.1.2 Entering/Returning from the Function Mode”.

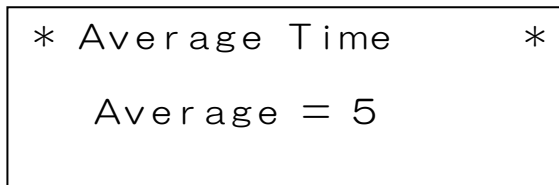

Note

When “Normal Meas” is set in “3.11 Average Measurement”, this average times setting screen is not indicated.

2. To input data, press the [CHANGE] switch.

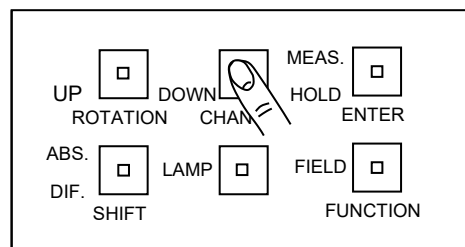
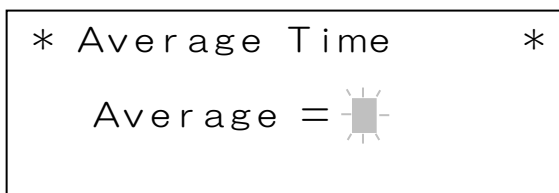

3. Input the desired numerical value according to the numerical value input method. You can input numerical values within the “1 – 20” range.

Setting method: ☞ “3.1.3 Setting Numerical Value”.

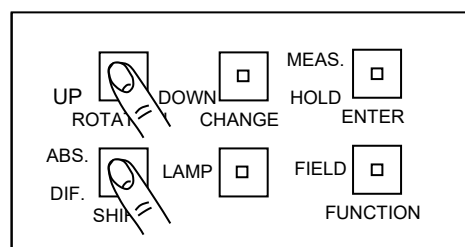
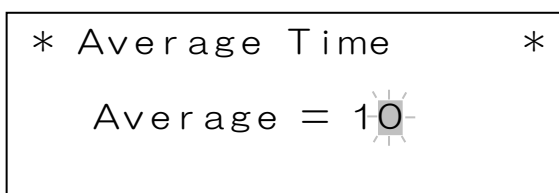

4. Press the [ENTER] switch to decide the value.

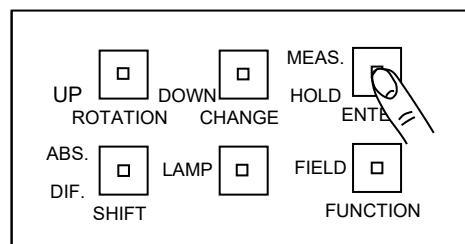
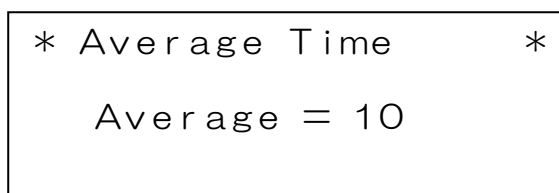

3.12 Selecting “OVER-RANGE” Detection in “MANU” Mode

When an “OVER-RANGE” error occurs and “ON” is set for this function, measurement is stopped.
When this function is “OFF”, “OVER-RANGE” error is not detected and measurement is performed.

Setting

1. Shift to the function mode. Access [MEASURE] from the function menu. Then, access the [MANU OVER ON/OFF] screen.

 “3.1.2 Entering/Returning from the Function Mode”.

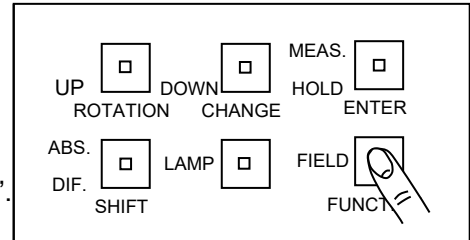

* MANU OVER ON/OFF *
MANU OVER = ON

Note

- “ON” is initially set.
- When any other mode except “MANU” is set in “3.2 Measurement Mode”, this setting screen is not indicated.

2. To change the setting, press the [CHANGE] switch. Press the [ROTATION] switch to change ON/OFF.

* MANU OVER ON/OFF *
MANU OVER = OFF

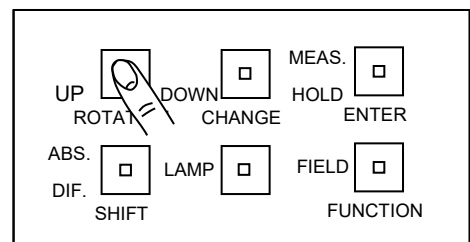

3. Press the [ENTER] switch to decide ON or OFF.

3.13 Beep Sound

Set whether beep sound should be used or not.

The setting procedures are described below.

1. Shift to the function mode. Access [DISPLAY] from the function menu. Then, access the [Beep ON/OFF] screen.

 “3.1.2 Entering/Returning from the Function Mode”.

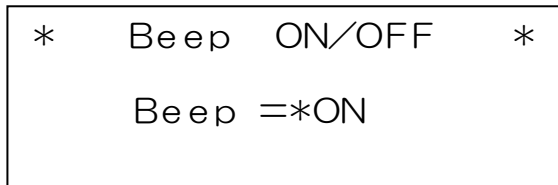

2. Press the [CHANGE] switch.
3. Press the [ROTATION] switch to select ON or OFF.
Each time you press the [ROTAION] switch, “ON (Used)” and “OFF (Not used)” are changed to each other.
4. After selecting, press the [ENTER] switch.

3.14 Maintenance Recommendation Display

Set the display method of maintenance recommendation after one year has passed since you purchased the instrument or calibration was performed.

There are two display methods.

- ON: Beep sound continues for 5 seconds and then, the system shifts to the next screen.
- OFF: The maintenance recommendation is not displayed and the system shifts to the next screen.



The lapse of time after purchasing or calibration is indicated by months.

Display:  "1.4 Maintenance Recommendation Display".

The setting procedures are described below.

1. Shift to the function mode. Access [MAINTAIN] from the function menu. Then, access the [Maintenance Display] screen.

 "3.1.2 Entering/Returning from the Function Mode".

Maintenance Display

*ON

2. Press the [CHANGE] switch.
3. Press the [ROTATION] switch to select ON or OFF.
Each time you press the [ROTATION] switch, ON and OFF are changed to each other.
4. After selecting, press the [ENTER] switch.

3.15 Setting Auto Panel Light

When measuring, the LC display unit and switch LED can be automatically turned ON/OFF.

When measuring, the stray light from the LC display unit and switch LED does not have influence and so measurement can be performed with higher accuracy.

The setting procedures are described below.

1. Shift to the function mode. Access [DISPLAY] from the function menu. Then, access the [Auto Panel Light] screen.

 "3.1.2 Entering/Returning from the Function Mode".



```
* Auto Panel Light *  
  
*ON
```

2. Press the [CHANGE] switch.
3. Press the [ROTATION] switch to select ON or OFF.
Each time you press the [ROTATION] switch, ON and OFF are changed to each other.
4. After selecting, press the [ENTER] switch.

3.16 Batch Deletion of Measurement Data/DIF Standard Data

Delete all of measurement data and all of DIF standard data at a time.

The procedures are described below.

1. Shift to the function mode. Access [MAINTAIN] from the function menu. Then, access the [Memory AllClear] screen.

 “3.1.2 Entering/Returning from the Function Mode”.

```
* Memory AllClear *  
  
CHANGE : Meas Data  
ROTATION : Std Sample
```

2. To delete all of measurement data at a time, press the [CHANGE] switch. To delete all of DIF standard data at a time, press the [ROTATION] switch.

The batch deletion screen appears.

```
*Meas Data AllClear*  
  
SHIFT : OK  
CHANGE : NO
```

This is the batch deletion screen for measurement data. The batch deletion screen for DIF standard data is similar to this.

3. Press the [SHIFT] switch.

All the measurement data are deleted and the preceding screen appears again.

 Remember	When you do not want to perform batch deletion, do not press the [SHIFT] switch but press the [CHANGE] switch. The data deleted by the batch deletion function cannot be restored. Be careful.
--	--

4. Communication with PC

4.1 Communication Command

This instrument can communicate with PC. This chapter will explain the commands when the customer creates his/her unique program for communicating with this instrument.

The communication commands list is shown below.

Communication command	Function
RM	Sets the instrument in the communication status (remote mode).
LM	Sets the instrument in the single unit status (local mode).
ST	The instrument starts measurement. After finishing measurement, data in text form is returned to PC. This command can be used in USB/RS-232C communication.
STB	The instrument starts measurement. After finishing measurement, data as binary data is returned to PC. The communication can be done at a higher speed than the above-mentioned "ST" command. This command can be used in USB communication only.
A0	Sets "AUTO" mode.
A1_#####	Sets "FREQ" mode. "#####" is frequency. Unit is "Hz".
A2_#####	Sets "MANU" mode. "#####" is integral time. Unit is "ms".
A3	Sets "SYNC" mode.
KW[n]_###	Writes correction factor in the instrument. n:0~430
KR[n]	Reads correction factor from the instrument. n:0~430
DR[n]	Reads the measurement data stored in the instrument. n:1~50
K[*]1	Changes the setting of correction factor in the instrument. K [*] 1: For spectrum *= O: Validates correction factor. *= N: Invalidates correction factor.
KOR1	Reads the correction factor setting in the instrument.
AVE_#	Changes the setting of average measurement. #: "0: Normal" and "1: Average"
AVER	Reads setting of average measurement.
AVT_#	Sets the times of average measurement. # is measurement times (1 – 20).
AVTR	Reads the setting of average measurement times.
FLD1	Changes the measuring angle to the 2.0 position.
FLD2	Changes the measuring angle to the 1.0 position.

Communication command	Function
FLD3	Changes the measuring angle to the 0.2 position.
FLD4	Changes the measuring angle to the 0.1 position.
FLDR	Reads the setting of the current measuring angle.
NL_####	Sets the delay time input of the integral time delay function. "####" is time [ms].
ND	Sets "ON" for the integral time delay function.
NF	Sets "OFF" for the integral time delay function.
WHO	Reads the luminance meter name.
SRL	Reads the serial number.
VER	Reads the program version.

"_" means space. "####" means a numerical value.

When the communication command is sent from PC, SR-NIR returns "OK" as the reception check command. If SR-NIR receives an irrelevant command, it returns "NO".

4.1.1 RM/LM Command

Set the instrument to remote status (remote mode) or single unit status (local mode).

RM: Set to remote mode.

LM: Set to local mode.

When turning on the power, local mode is initially set. When the instrument is moved for communication with PC, it is necessary to send "RM" command first and change to remote mode.

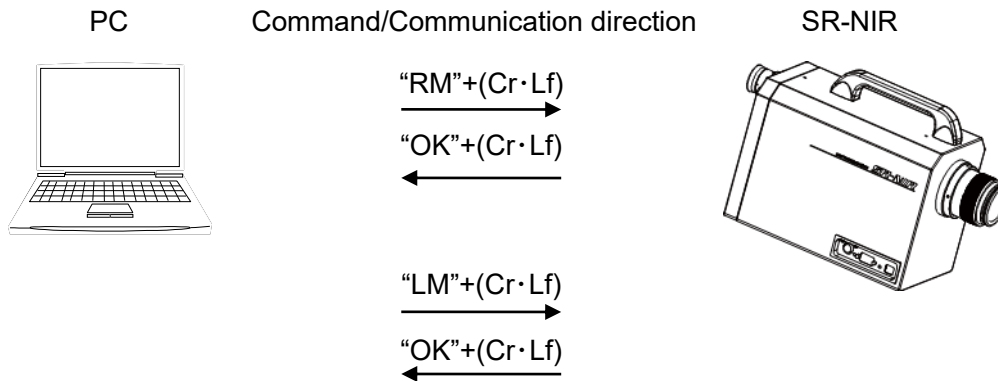

4.1.2 ST Command

"ST" command

When PC sends this command to the instrument, measurement starts. After finishing measurement, the instrument returns the measurement data in text form to PC.

① Sending from PC to the instrument

After activating RS-232C communication, PC sends the character line "ST" (ASCII code: 53H/54H) and then, sends "Cr (0Dh)" and "Lf (0Ah)".

② Reception check from the instrument

When the instrument receives "ST" + (Cr·Lf), it returns the check command "OK" + (Cr·Lf). Then, the instrument starts measurement.

Note

As an example, (Cr·Lf) is used as a delimiter in the explanation. The delimiter can be changed to (Cr).

☞ "3.8 Terminal Code of Remote Command".

③ Communication of measurement data

After finishing measurement, the instrument sends the measurement conditions and data to PC. When the data is sent, the delimiter (Cr·Lf) is added to the end of one data line. After all the data are sent, "END" is sent as the finish code at last.

Output format of measurement data: ☞ "4.2.1 Output Format of Remote Measurement".
The communication method is different according to setting.

Setting of communication method: ☞ "3.7 Data Communication Method".

(1) Normal Type

When this method is selected, the "0×60, 0×15" data check is not performed compared with "(2) Handshake Type". SR-NIR keeps sending the data until "END".

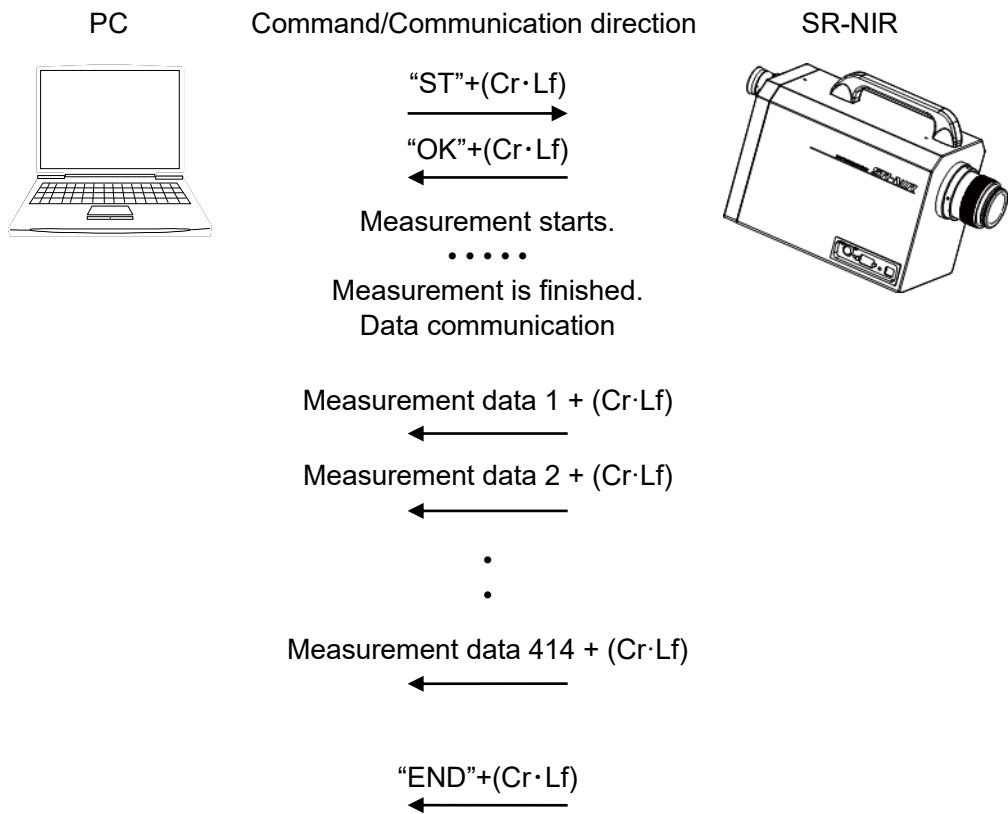

(2) Handshake Type

When this method is selected, each time the instrument sends 1 data, the processing mentioned below is performed.

When data is correct, $0x06+(Cr·Lf)$ is sent.

When data is not correct, $0x15+(Cr·Lf)$ is sent.

When $0x15+(Cr·Lf)$ is sent, the data is sent again.

However, one data is resent only once. If incorrect data is sent twice continuously, "END" + (Cr·Lf) is output and communication is finished.

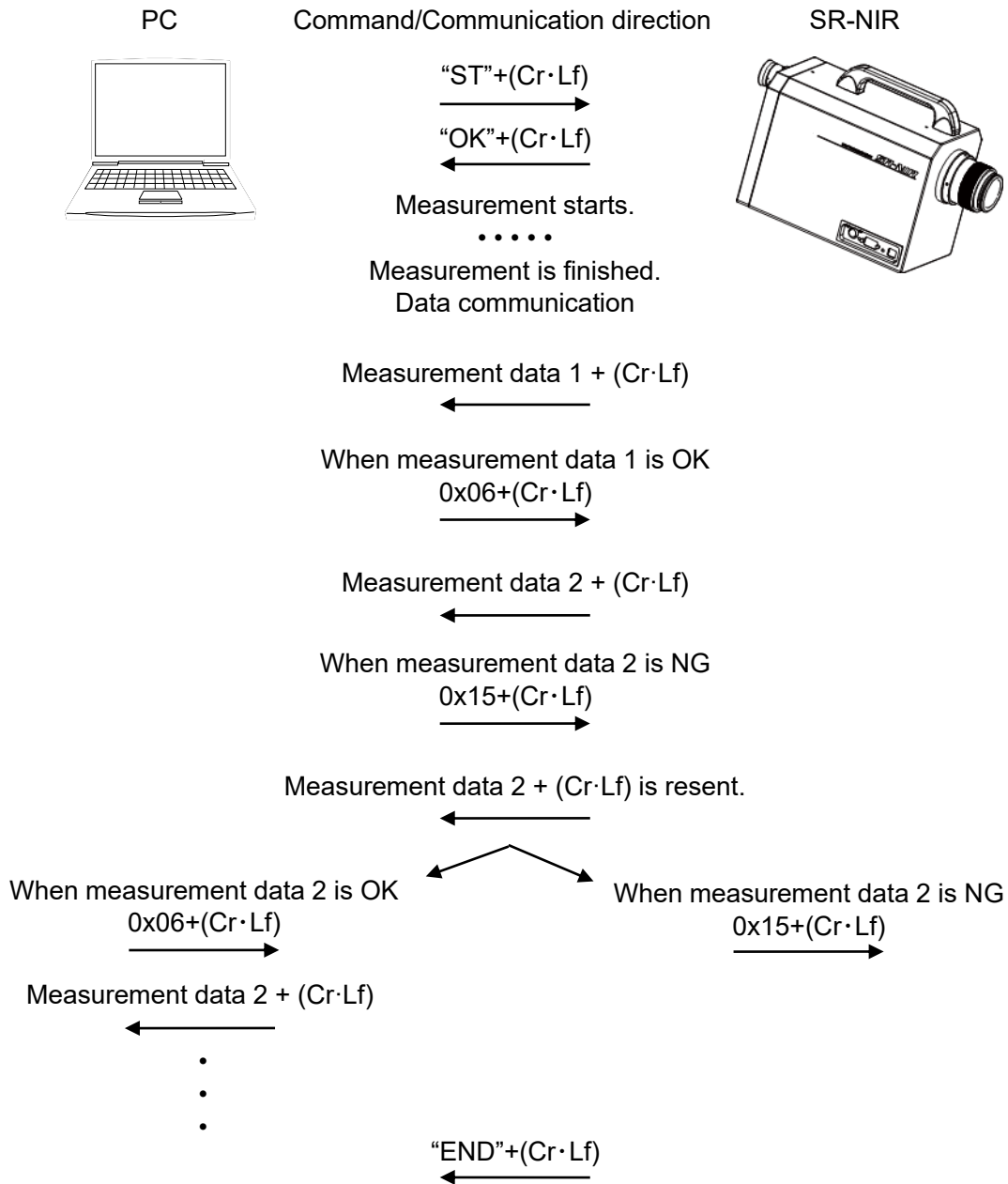

4.1.3 STB Command

“STB” command

When PC sends this command to the instrument, measurement starts. After finishing measurement, the instrument returns the measurement data as binary data (Big Endian) to PC. The difference from “ST” command is described below.

Output format of measurement data:  “4.2.1 Output Format of Remote Measurement”.

1. Communication can be done at a higher speed than “ST” command.
2. The resending function support is not used.

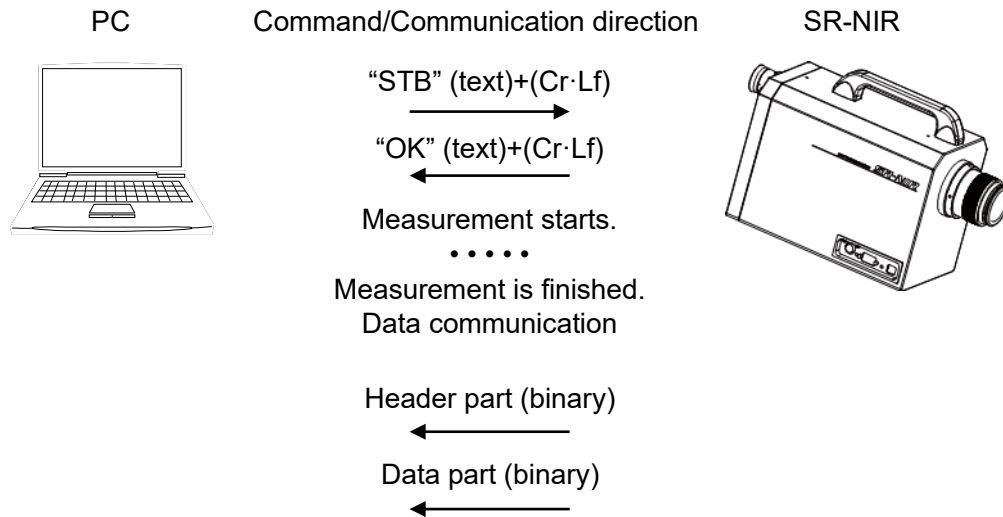

4.1.4 A0/A1/A2/A3 Command

Change the measurement mode in the instrument.

This setting is stored even after the power is OFF. If "ST" command is sent without sending this command, the measurement mode, which has been set before sending, is used for measurement.

Command	Measurement mode	
A0	: AUTO	
A1_#####	: FREQ	"_" is space. "#####" is frequency. 0 – 250 Hz
A2_#####	: MANU	"_" is space. "#####" is integral time.
A3	: SYNC	20 – 15000 ms

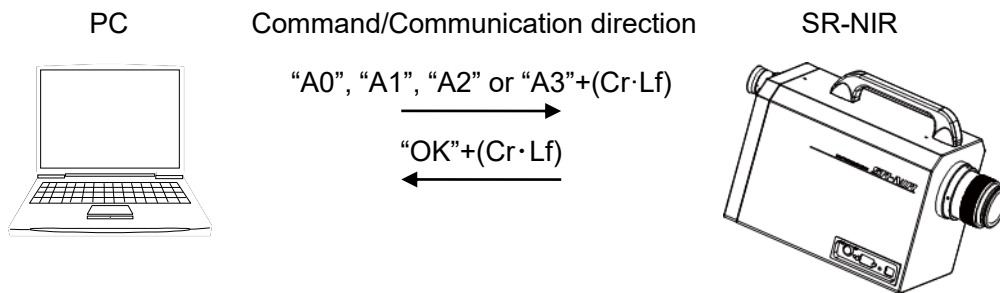

4.1.5 KW [n] Command

Write the correction factor in the instrument. Input 0 to 430 to "n". It is possible to be applied to 600 – 1030nm at intervals of 1nm. The factor can be input by one waveform and is sent with the form "KW [n]_#.###".

When the instrument receives the correction factor, it returns "OK" as the reception check command.

Example) KW0_1.000+(Cr·Lf) "_" is space.
 Input the correction factor 1.000 to "n=0 (600nm)".

KW0	:	600 nm
KW1	:	601 nm
KW2	:	602 nm
• • • • •		
• • • • •		
KW429	:	1029 nm
KW430	:	1030 nm

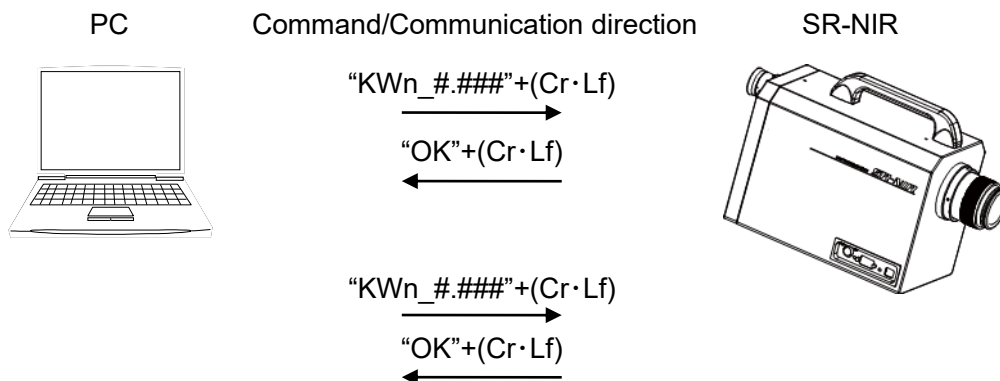

4.1.6 KR [n] Command

Read the correction factor stored in the instrument. Input 0 to 430 to “n” and it is possible to be applied to 600 – 1030nm at intervals of 1nm.

KR0 : 600 nm
KR1 : 601 nm
KR2 : 602 nm
• • • • •
KR429 : 1029 nm
KR430 : 1030 nm

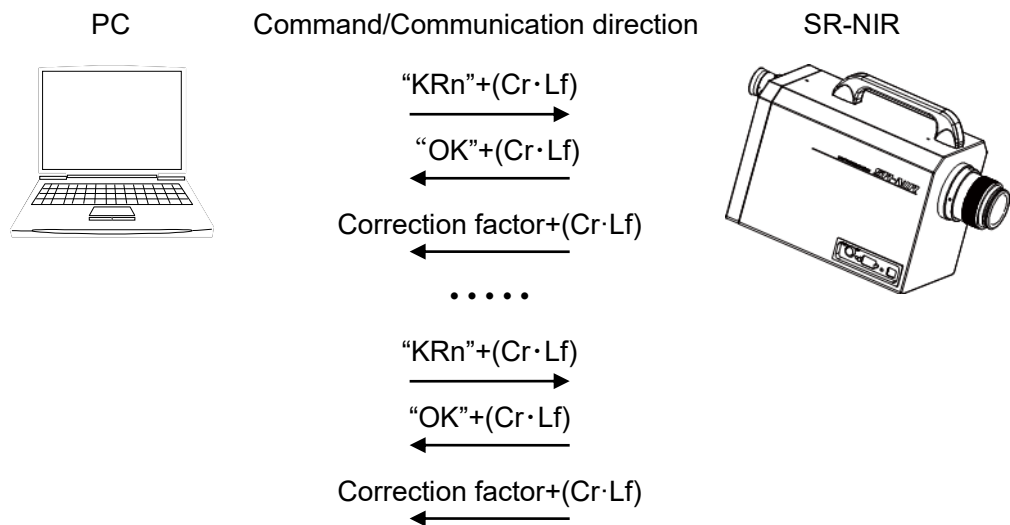

4.1.7 DR [n] Command

Perform local measurement and read the measurement data stored in the instrument to write it in PC. Specify 1 to 50 for “n”.

☞ “1.3.2 Connecting PC”.

☞ “4.2.2 Output Format for Reading Internal Stored Data”.

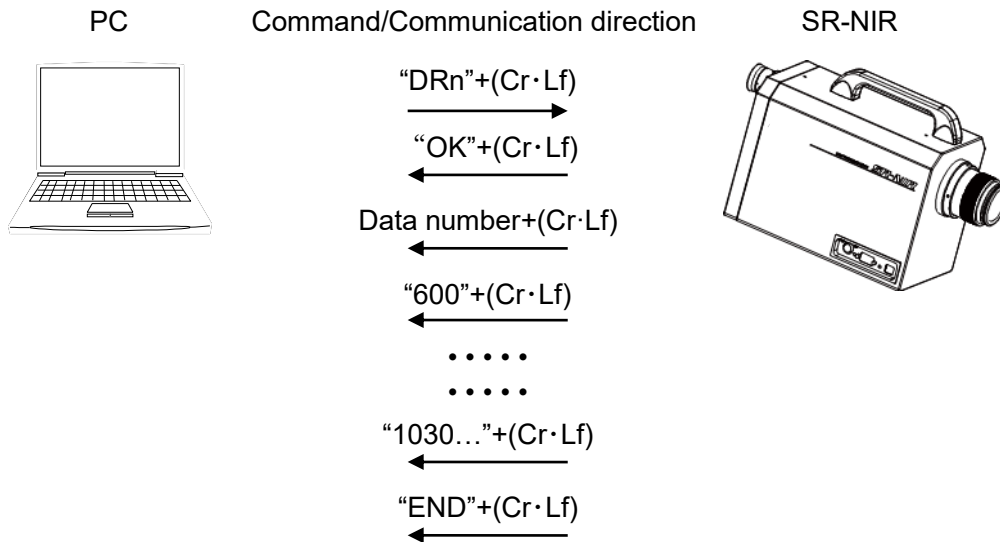

4.1.8 KO1/KN1 Command

Change the setting for using the correction factor in the instrument.

KO1 : Change the setting to use the spectrum correction factor in the instrument.

KN1 : Change the setting not to use the spectrum correction factor in the instrument.

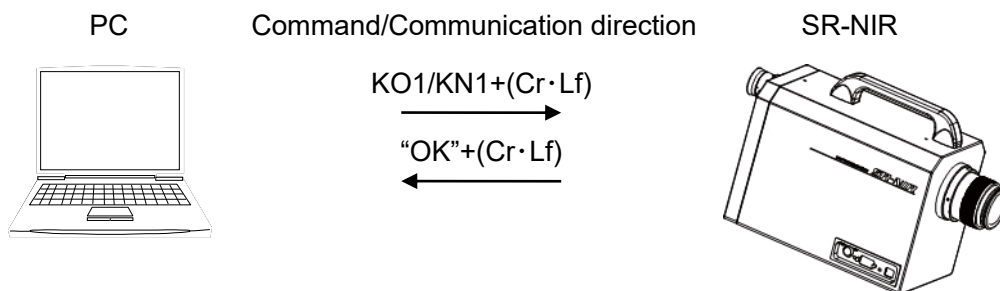

4.1.9 KOR1 Command

Read the setting of the correction factor in the instrument.

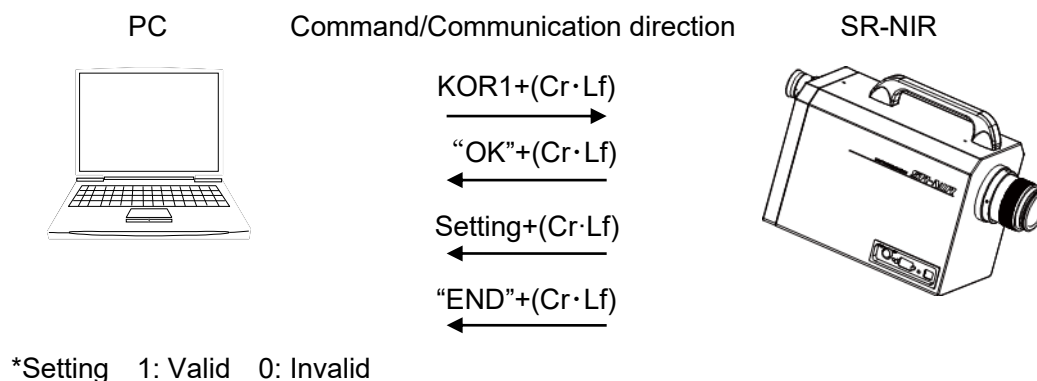

4.1.10 AVE Command

Set the use of average measurement in the instrument.

AVE_# : “#” is 0 or 1.

0: Average measurement is not done.

1: Average measurement is done.

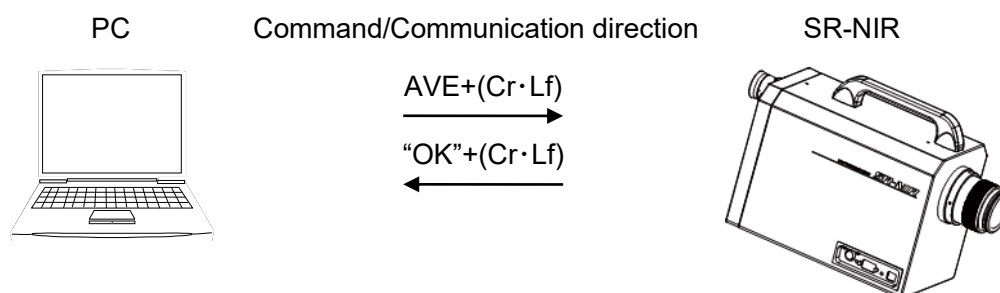

4.1.11 AVER Command

Read the setting of average measurement in the instrument.

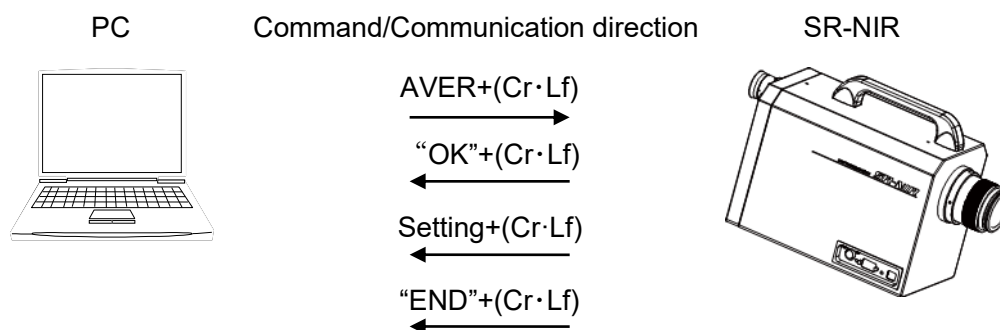

4.1.12 AVT Command

Set the times of average measurement in the instrument.

AVT_# : “#” is the measurement times “0 – 20”.

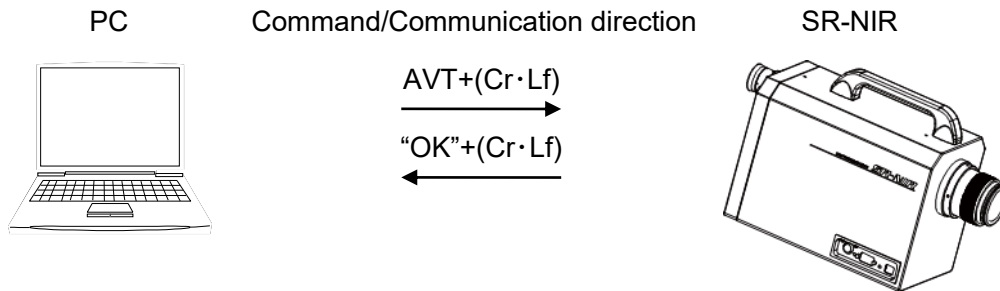

4.1.13 AVTR Command

Read the setting of the average measurement times in the instrument.

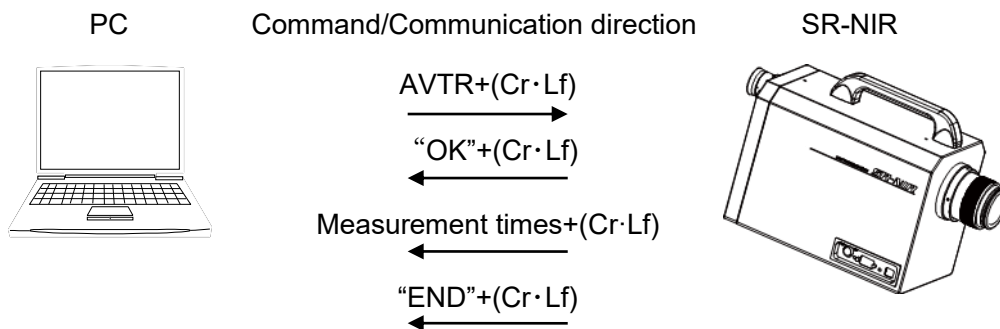

4.1.14 FLD1/FLD2/FLD3/FLD4 Command

Change the setting for the measuring angle in the instrument.

- FLD1 : Change the measuring angle to the 2.0 position.
- FLD2 : Change the measuring angle to the 1.0 position.
- FLD3 : Change the measuring angle to the 0.2 position.
- FLD4 : Change the measuring angle to the 0.1 position.

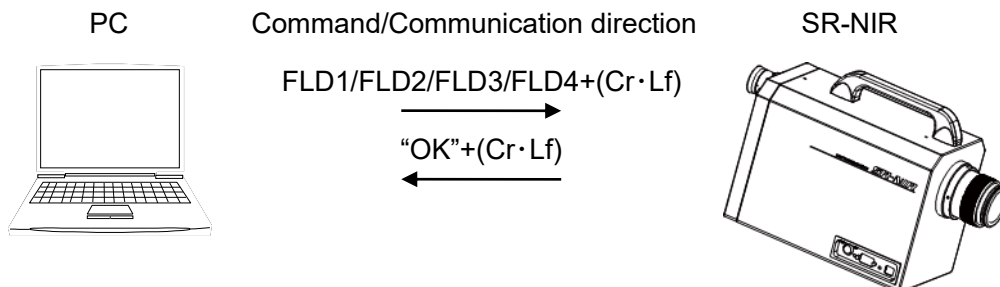

4.1.15 FLDR Command

Read the current measuring angle setting in the instrument.

- 1 : The measuring angle is at the 2.0 position.
- 2 : The measuring angle is at the 1.0 position.
- 3 : The measuring angle is at the 0.2 position.
- 4 : The measuring angle is at the 0.1 position.

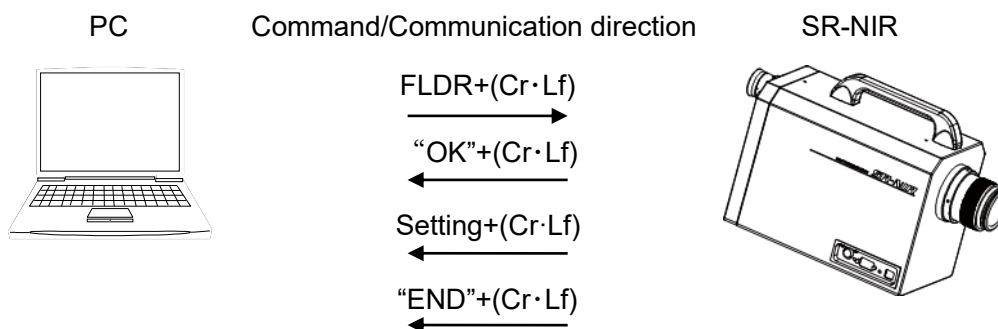

4.1.16 NL Command

Set the integral time of the integral time delay function in the instrument.

NL_#### : “#” is integral time. Unit is “ms” (50 – 3000).

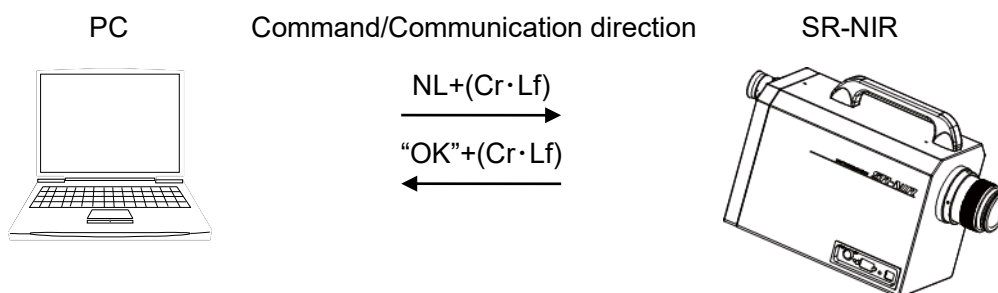

4.1.17 ND/NF Command

Change ON/OFF of the integral time delay function in the instrument.

- ND : Validates the integral time delay function.
- NF : Invalidates the integral time delay function.

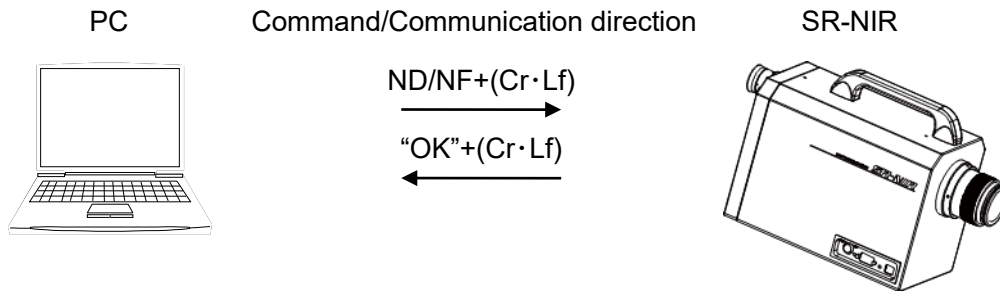

4.1.18 WHO/SRL/VER Command

Read the luminance meter name, serial number and program version in the instrument.

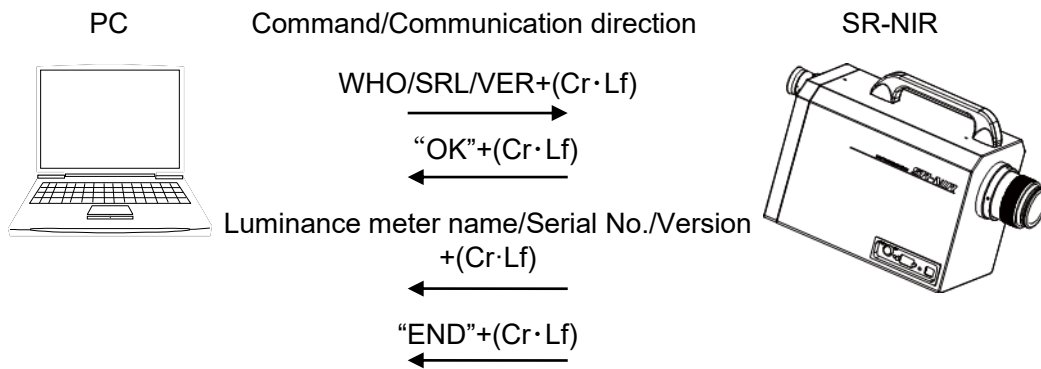

4.2 Output Format

4.2.1 Output Format of Remote Measurement

(1) "ST" command

When measurement is done with this command, the following measurement results are returned in text form.

☞ "4.1.2 ST Command".

Line No.	Output data	Remarks
1.	2	Observation measuring angle
2.	100	Integral time
3.	600 2.133333E-04	Wavelength and spectral radiance
4.	601 2.141231E-04	
5.	602 2.420037E-04	
...	
432.	1029 4.325765E-03	
433.	1030 4.294558E-03	
434.	END	Data end command

(2) "STB" command

When measurement is done with this command, the following measurement results are returned as binary data (Big Endian).

☞ "4.1.3 STB Command".

1 Header section

There is the information that is necessary to receive the data section.

Start byte	Contents	Data type	Size	Element number	Remarks
1	Size of data section	Unsigned integer	4	1	
5	Check sum of data section	Unsigned integer	1	1	
		Data size	5B (byte)		

Check sum of data section: Each data section is added from the first to the next in order and the lowest 1B (byte) of the total is extracted.

2 Data section (when measurement is finished)

Start byte	Contents	Data type	Size	Element number	Remarks
1	Measuring angle	Unsigned integer	1	1	1:2°, 2:1°, 3:0.2°, 4:0.1°
2	Accumulation time	Floating point number	4	1	
6	Wavelength position	Unsigned integer	2	1	Fixed at 600nm.
8	Spectral radiance	Floating point number	4	1	Spectral radiance of 600nm
12	Wavelength position	Unsigned integer	2	1	Fixed at 601nm.
14	Spectral radiance	Floating point number	4	1	Spectral radiance of 601nm
⋮	⋮	⋮	⋮	⋮	
2580	Wavelength position	Unsigned integer	2	1	Fixed at 1030nm.
2582	Spectral radiance	Floating point number	4	1	Spectral radiance of 1030nm
2586	“END”+Cr+Lf is fixed.	Character code	1	5	
		Data size	2590		

3 Data section (When an error occurs)

Start byte	Contents	Data type	Size	Element number	Remarks
1	Error code	Character code	1	4	
5	“END”+(Cr·Lf)	Character code	1	5	
		Data size	9		

Error code:  “5.2 Error Code in Communication”.

4.2.2 Output Format for Reading Internal Stored Data

The output format of the data, which are stored in the instrument by measuring in local mode, is described in the following table.

Line No.	Output data	Remarks
1.	n	Data number
2.	2	Observation measuring angle
3.	100	Integral time
4.	600 2.133333E-04	Wavelength and spectral radiance
5.	601 2.141231E-04	
6.	602 2.420037E-04	
...	
432.	1029 4.325765E-03	↓ Data end command
433.	1030 4.294558E-03	
434.	END	

4.3 Installing USB Driver

The procedures to install USB driver are described below.

1. Set CD-ROM into the CD-ROM drive.
2. Open the CD-ROM drive from Explorer. Double-click the “dpinst.exe” file in the “[OS name]-[x64] or [x86]” folder within the [USB_DRIVER] folder.

Example: When you use Windows10/11 (64bit), double-click the following folder.

USB_DRIVER \Windows10\x64

Applicable OS	Windows® 10 Pro (32bit / 64bit) Windows® 11 Pro (64bit)
---------------	--

3. The user account control dialog box is displayed. Click the [Yes] button.
4. The install wizard dialog box of Device Driver is displayed. Click the [Next] button.

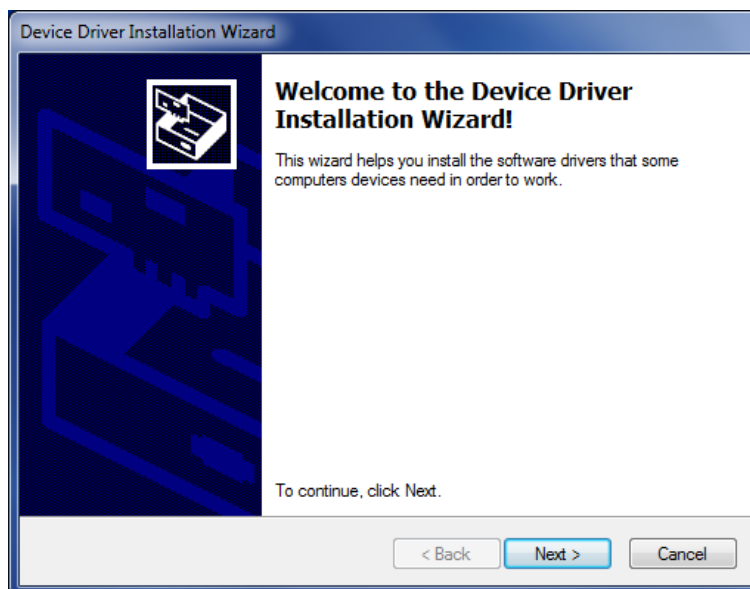

5. The following screen appears and installation starts.

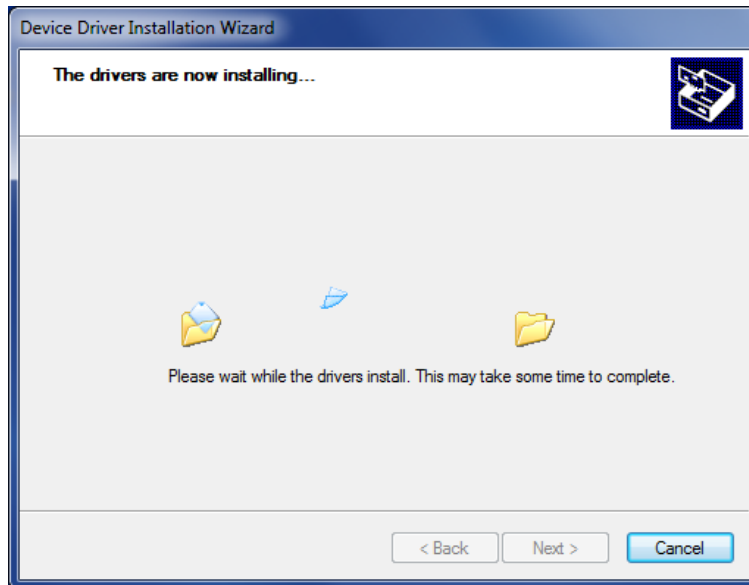

6. When the driver installation is completed, the following screen appears. Click the [Complete] button.

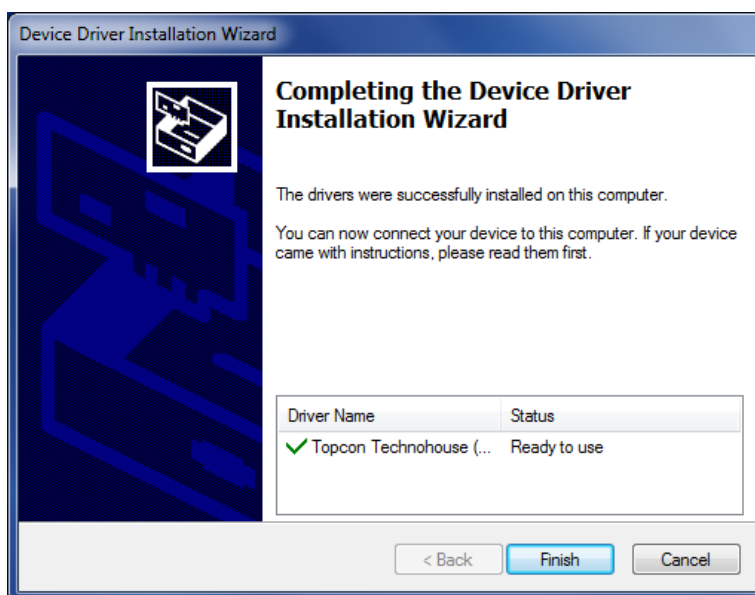

5. Error Display

5.1 Error Display of Instrument

Error display	Contents	Remedial measure
<pre> Attention!! Temperature Not set Please Power OFF </pre>	<p>Because the instrument inside is hot, the protective circuit works. Turn off the power.</p>	<p>Turn off the power and leave the instrument as it is under the use condition (5 - 35°C) for about 30 minutes. Then, turn on the power.</p>
<pre> Attention!! Low Battery Continue:FIELD </pre>	<p>The level of the backup battery power is lowered. If you continue the operation, press the "FIELD" switch.</p>	<p>The level of the measurement data backup battery power is lowered and the data stored in the measuring instrument may be erased. It is necessary to replace the battery. Contact our company or the retailer shop where you purchased the instrument. <u>When you do not turn off the power, this error does not have influence on measurement.</u></p>
<pre> *** ERROR *** E001 Over Range hit any key </pre>	<p>The instrument exceeds the measurement range. Press any of the switches.</p>	<p>Take the following remedial measures or others.</p> <ul style="list-style-type: none"> - Lower the brightness of the measurement target. - Select a smaller measuring angle. - Insert a neutral density filter.
<pre> *** ERROR *** E004 Sync Error hit any key </pre>	<p>The external synchronizing signal capturing error occurs. Press any of the switches.</p>	<p>The external synchronizing signal is not captured normally. Check the synchronizing signal generating device and the connection of BNC cable.</p>
<pre> *** ERROR *** E0XX Comm Error </pre>	<p>E005 – E007 Communication error occurs.</p>	<p>Check the communication conditions.</p>
<pre> *** ERROR *** E9XX XXXXXXXXXXXXXXXXX hit any key </pre>	<p>E900 - E999 Internal error occurs. Press any of the switches.</p>	<p>Internal error occurs. Contact our company or the retailer shop where you purchased the instrument.</p>

- When the error is still displayed after you have taken the above-mentioned remedial measures, repair may be necessary. Contact our company or the retailer shop where you purchased the instrument.

5.2 Error Code in Communication

When errors occur in the instrument, which is measuring a target in combination with PC, the instrument sends the error messages mentioned in the table below to PC.

Error code	Contents
E001	<p>OVER-RANGE</p> <p>When the brightness of the measurement target exceeds the instrument's measurable range, this code is returned.</p> <p>Take the following remedial measures and others.</p> <ul style="list-style-type: none">- Lower the brightness of the measurement target.- Select a smaller measuring angle.- Insert the neutral density filter.
E002	<p>The [MEAS./HOLD] switch is pressed on the instrument during remote measurement and so measurement is stopped.</p>
E004	<p>The external synchronizing signal is not captured normally in the instrument. Check the synchronizing signal generating device and the connection of BNC cable.</p>
E900 – 999	<p>Internal error occurs in the instrument. Contact our company or the retailer shop where you purchased the instrument.</p>

6. Appendices

Specifications and Performance

■ SR-NIR Specifications and Performance

Optical system

Objective lens	Focal length	f=82 mm	F 2.5
Eyepiece lens	Viewfinder visual field	5°	
	Diopter adjustment range	±5 diopt	

Spectroscope

Spectral wavelength width	5 – 8 nm
Spectroscopic method	Polychromator
Dispersion element	Diffraction grating

Photo detector Electronic cooling linear array sensor

Measuring angle 2°/ 1°/ 0.2°/ 0.1° Electrical changing type

Measuring distance 350 mm – ∞ (Distance from the objective lens hardware tip)

Measuring wavelength range 600 nm – 1030 nm

Wavelength resolution 1 nm

Measurement mode Auto/Manual (Frequency/Integral time), and input of external vertical synchronizing signal

Measuring diameter

(mmø)

Measuring angle	Measuring distance (mm)							
	350	400	500	600	800	1000	2000	5000
2°	10.0	11.7	15.1	18.6	25.4	32.2	66.4	169
1°	4.99	5.84	7.55	9.26	12.7	16.1	33.2	84.4
0.2°	1.00	1.17	1.51	1.86	2.54	3.22	6.64	16.9
0.1°	0.50	0.59	0.76	0.93	1.27	1.61	3.32	8.44

* The measuring distance is the distance from the objective lens hardware tip.

* The values in this table are design standard values and are different from the real diameters from time to time.

Measuring function

The following measurement can be done.

- Spectral radiance W/sr·m²·nm

Measuring time

Approx. 1 – 31 seconds (excluding communication time)

Communication time

Remote (USB communication) STB command	Approx. 0.9 sec.
Remote (USB communication) ST command	Approx. 2.2 sec.
Remote (RS232C communication) ST command	Approx. 7.1 sec.

*Communication time is changed due to the PC operating environment or others.

Linearity

Within ±7% (600nm – 1030nm against our company's standard light source)

Repeat accuracy

±2% or less (600nm – 1030nm against our company's standard light source)

Wavelength accuracy	±0.5nm (against centroid wavelength Hg bright line)
Measuring range	In the case of standard light source A Measuring angle 2° : 0.5 – 3,000cd/m ² Measuring angle 1° : 1 – 9,000cd/m ² Measuring angle 0.2° : 20 – 70,000cd/m ² Measuring angle 0.1° : 100 – 300,000cd/m ²
Temperature characteristics	Radiance: Within ±3% (Within 5°C – 35°C, the luminance of 20°C should be standard.)
Response characteristics against linear polarization	Spectral radiance 5% or less
Calibration standard	TechnoOptis calibration standard (Standard light A, 23°C±3°C, 65%RH or less)
Display	Dot matrix LC (liquid crystal) display, 20 letters × 4 lines, with illumination function
Interface	USB2.0 (applicable to full speed mode 12 Mbps) RS-232C Communication speed 4800/9600/19200/38400 bps Data length 7 bits/8 bits Parity ODD/EVEN/NONE Stop bit 1 bit/2 bits
Power supply	Exclusive AC adapter (standard accessory)
Power consumption	Approx. 36W
Operating temperature	Temperature : 5°C - 35°C Humidity : 80%RH or less
Storage conditions	Temperature : -10°C - 50°C Humidity : 80%RH or less
External dimensions	Approx. 406mm (Length) × 150mm (Width) × 239mm (Height)
Mass	Approx. 5.5kg (Only the instrument body)

FCC Compliance Information

This device complies with Part 15 of FCC Rules. Operation is subject to the following two conditions:
(1) the device may not cause interference, and
(2) the device must accept any interference, including interference that may cause undesired operation of this device.

This equipment has been tested and found to comply with the limits for a Class A digital device, pursuant to part 15 of the FCC Rules.

These limits are designed to provide reasonable protection against harmful interference when the equipment is operated in commercial environment. This equipment generates, uses, and can radiate radio frequency energy and if not installed and used in accordance with the instruction manual, may cause harmful interference to radio communications. Operation of this equipment in a residential area is likely to cause harmful interference in which case the user will be required to correct the interference at his own expence.

Republic of Korea	KC:Class A	해당 무선설비는 전파혼신 가능성이 있으므로 인명안전과 관련된 서비스는 할 수 없습니다 A급 기기 (업무용 방송통신기자재) 이 기기는 업무용(A급) 전자파적합기기로서 판매자 또는 사용자는 이 점을 주의하시기 바라며, 가정외의 지역에서 사용하는 것을 목적으로 합니다
-------------------	------------	--

Block Diagram

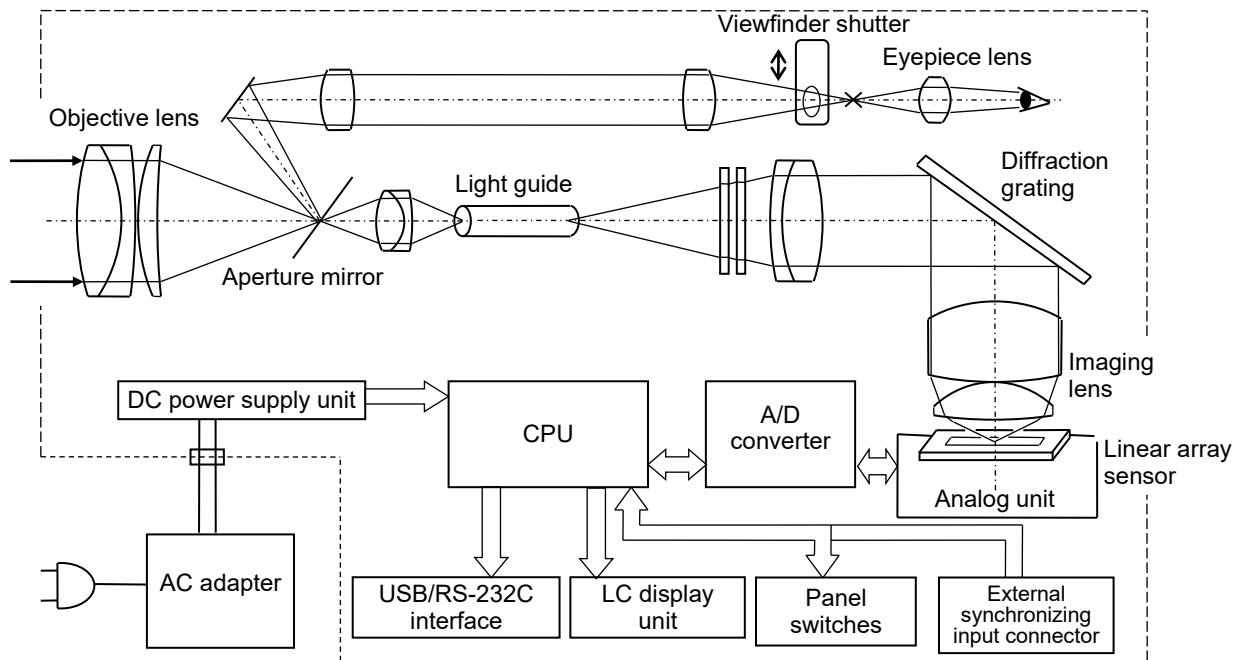

Warranty

Warranty Period

One year from the date of shipment

Repairs during the Warranty Period

Failure occurs to the instrument when the instrument has been operated according to the instruction manual and, the failure caused by design or manufacture will be repaired free of charge.

Repairs after Warranty Period

Repair after the warranty period is carried out if possible and have to be paid in full by the user.

Maintenance Period

The repair parts (*1) are retained by us for eight years (*2) after purchase.

The repairable period is this period that parts are kept in stock.

Even after the storage period has elapsed, there are cases in which repair may be possible, so contact the dealer or TechnoOptis.

(*1) Maintenance and repair parts are parts that are necessary to maintain the function of the product.

(*2) We make our most effort to keep maintenance and repair parts in stock for the complete storage period, however, due to some unexpected occurrence, the storage period may have to be shortened.

Disposal

When disposing of the product, do so according to the local government ordinance regarding disposal and recycling.

Perchlorate Material – special handling may apply.

See <http://www.dtsc.ca.gov/hazardouswaste/perchlorate/>

Note; This is applicable to California, U.S.A only

When you ask for service, advice us of the following data.

- | | |
|-------------------------------|---|
| · Manufacturing serial number | Located on the Name plate on the bottom of the device. |
| · Period of use | The date of purchase of the instrument, and date of last calibration. |
| · Operating conditions | Type of light source measured, device settings, measurement values, measurement state, etc. |
| · Problem | Description of the trouble as much detail as possible. |

Make inquiries to the address indicated on the base of the instruction manual.

Spectroradiometer

SR-NIR

Contact information

TechnoOptis Co., Ltd.

4F, Imas Itabashi BASE, 2-4-1, Sakashita, Itabashi-ku, Tokyo 174-0043 JAPAN

◆ **For inquiries about the product:**

Sales section: Phone: +81-3(3558)2666 Fax: +81-3(3558)4661

◆ **For inquiries about the after-care service including repairs:**

Maintenance service section: Phone: +81-3(3558)2710 Fax: +81-3(3558)3011

Spectroradiometer SR-NIR Instruction Manual

Date of Issue of 1st edition March, 2008

11th edition June, 2026

Published by: TechnoOptis Co., Ltd.

©2008 TechnoOptis Co., Ltd.

ALL RIGHTS RESERVED

Copying and reproduction without permission are prohibited.